

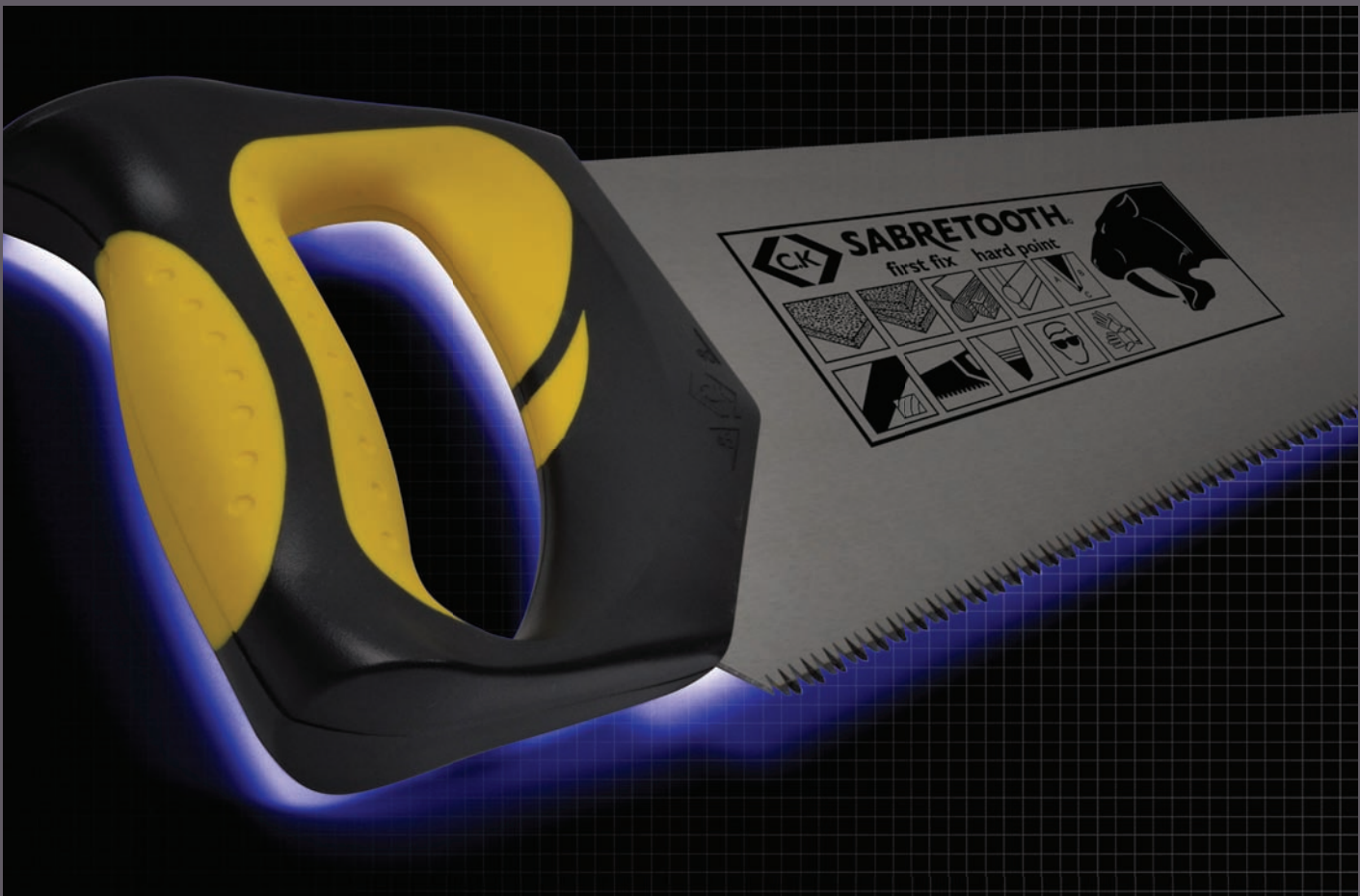

**C.K TOOLS**

PRODUCT RANGE

Version 1





**DESIGNED FOR PROFESSIONALS**  
**QUALITY**  
**INNOVATION**  
**BRAND LEADERSHIP**

For over 100 years, C.K has been at the forefront of hand tool manufacturing, producing high quality tools that meet the most demanding needs of trade professionals.

Backed by a lifetime guarantee, C.K tools are engineered to offer leading performance, durability, accuracy and strength, all of which are key requirements for professional results. Not content with simply conforming to all relevant international standards, C.K work with metallurgical and design engineers to develop new materials, manufacturing techniques and finishing treatments to push the boundaries of performance.

Driven by research through an extensive panel of cross trade professionals, tools are developed to assist with every day tasks; an approach proven to produce innovative tools that transform traditional working practices.

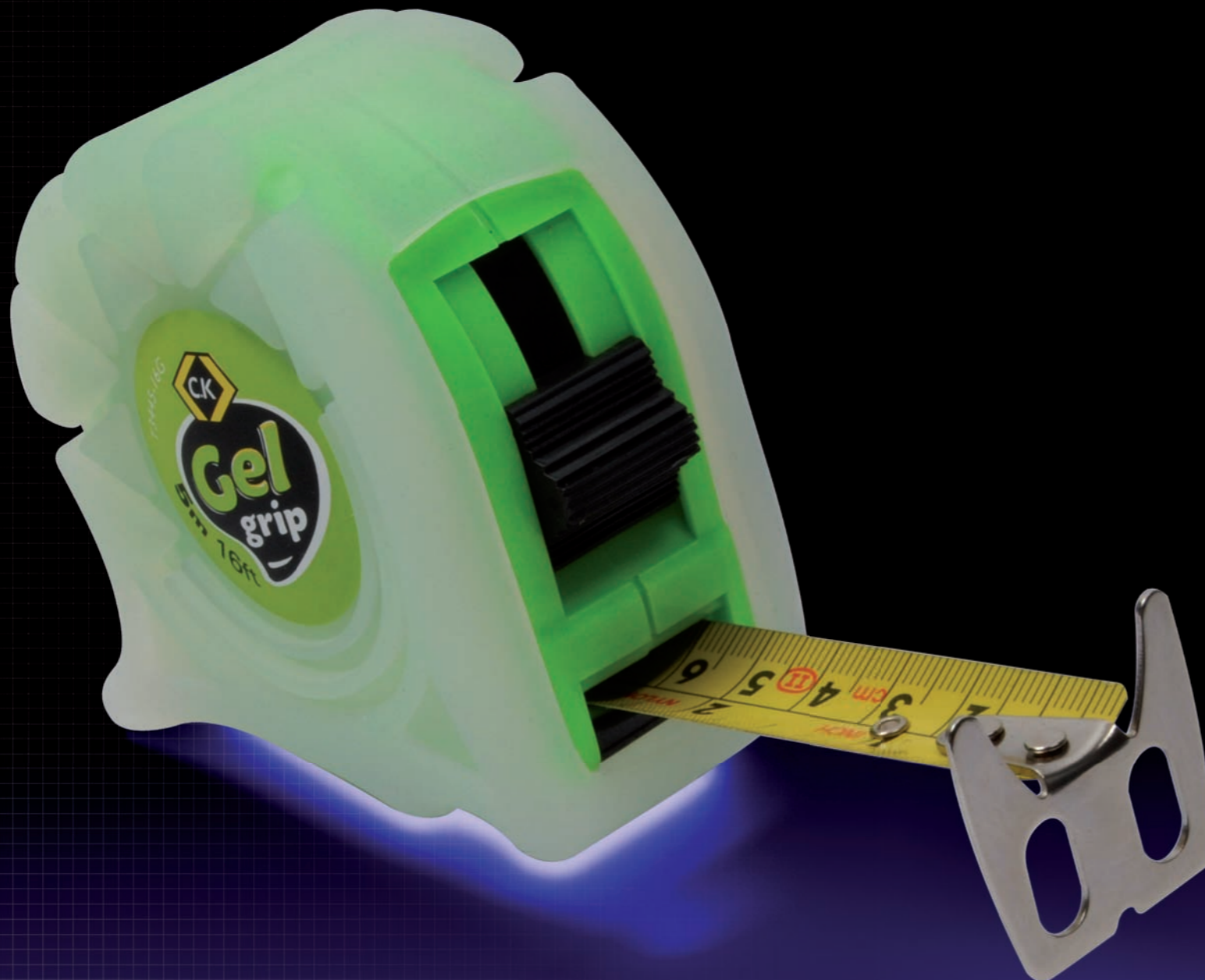

**ENTWICKELT FÜR FACHLEUTE**  
**PRODUKTQUALITÄT**  
**INNOVATION**  
**MARKENFÜHRER**

**CONÇU POUR LES PROFESSIONNELS**  
**QUALITÉ DES PRODUITS**  
**INNOVATION**  
**RENOMMÉE DE LA MARQUE**

**DISEÑADO PARA PROFESIONALES**  
**CALIDAD DEL PRODUCTO**  
**INNOVACIÓN**  
**LIDERAZGO DE MARCA**

Seit über 100 Jahren steht C.K an vorderster Front der Handwerkzeugherstellung und fertigt hochqualitative Werkzeuge, die den anspruchsvollsten Bedarf von Fachleuten erfüllen.

Mit einer lebenslangen Garantie versehen sind C.K-Werkzeuge führend in Leistung, Dauerhaftigkeit, Genauigkeit und Beanspruchung - all das sind Schlüsselanforderungen für professionelle Ergebnisse. Neben der Übereinstimmung mit allen einschlägigen internationalen Standards arbeitet C.K mit Metallurgen und Ingenieuren an der Entwicklung neuer Werkstoffe, Technologien und Oberflächenbehandlungen, um die Leistungsgrenzen weiter nach oben zu verschieben. Unterstützt durch die Zusammenarbeit mit einem großen Kreis von berufsübergreifender Fachleuten werden Werkzeuge entwickelt, die zur Umsetzung von täglichen Aufgaben einen erheblichen Beitrag leisten.

Depuis plus de 100 ans, C.K est une entreprise de premier plan dans la fabrication d'outils à main de haute qualité qui répondent aux besoins les plus contraignants des utilisateurs professionnels.

Bénéficiant d'une garantie à vie, les outils C.K sont mis au point techniquement pour offrir performances de pointe, durabilité, exactitude et résistance, autant d'exigences essentielles pour des résultats professionnels.

Ne se contentant pas de se conformer à l'ensemble des normes internationales en vigueur dans ce domaine, C.K travaille avec des ingénieurs métallurgistes et des bureaux d'études à l'élaboration de nouveaux matériaux, de nouvelles techniques de fabrication et de nouveaux traitements de finition afin de repousser les limites de ses outils en termes de performance.

Fruit d'enquêtes menées auprès d'un panel interprofessionnel étendu, les outils sont élaborés dans l'optique de faciliter les tâches quotidiennes ; une démarche concrétisée par la réalisation d'outils innovants qui transforment les méthodes de travail traditionnelles.

Durante más de 100 años, CK ha estado a la vanguardia de la fabricación de herramientas manuales, produciendo herramientas de alta calidad que satisfagan las necesidades más exigentes de los profesionales del sector.

Respaldadas por una garantía de por vida, las herramientas de CK están diseñadas para ofrecer un rendimiento, durabilidad, precisión y resistencia inmejorables, todos ellos requisitos fundamentales para obtener resultados profesionales.

No nos contentamos simplemente en cumplir con todos los estándares internacionales pertinentes, en CK, además, trabajamos con diseñadores e ingenieros metalúrgicos para desarrollar nuevos materiales, nuevas técnicas de fabricación y nuevos tratamientos de acabado para ampliar los límites del rendimiento.

Motivados por la investigación a través de un amplio panel de profesionales del sector, hemos desarrollado herramientas que nos ayudan en las tareas diarias, un método de probada eficacia para fabricar herramientas innovadoras que transformen las prácticas de trabajo tradicionales.

















With an established reputation for premium quality, innovative products, C.K tools are the trusted choice of trade professionals. Supported with advanced marketing techniques designed to drive demand and maximize sales, C.K continues to strengthen its brand leadership throughout the world.

Die Premium-Qualität unserer innovativen Produkte macht C.K-Werkzeuge zur ersten Wahl bei Fachleuten. Darüber hinaus unterstützt modernstes Marketing den weltweiten Verkauf und untermauert die führende Position von C.K in den internationalen Märkten.

Avec une réputation établie de qualité supérieure et de produits innovants, C.K tools est une marque d'outillage que les utilisateurs professionnels choisissent en toute confiance. Prenant appui sur des techniques commerciales évoluées conçues pour stimuler la demande et optimiser les ventes, l'entreprise C.K continue à renforcer la renommée de sa marque à travers le monde.

Con una sólida reputación de fabricar productos de alta calidad e innovadores, las herramientas de CK son la elección de confianza de los profesionales del sector. Gracias a las técnicas avanzadas de marketing diseñadas para impulsar la demanda y maximizar las ventas, CK sigue fortaleciendo su liderazgo de marca en todo el mundo.

CONTENTS . INHALT . CONTENU . CONTENIDO

 <b>6-27</b>	<b>PLIERS &amp; CUTTERS</b> ZANGEN SCHNEIDWERKZEUGE PINCES ALICATES Y CORTADORE	 <b>104-111</b>	<b>ENGINEER'S TOOLS</b> MECHANIKERWERKZEUGE OUTILS MECHANIQUES HERRAMIENTAS DE MECÁNICO
 <b>28-47</b>	<b>SCREWDRIVERS</b> SCHRAUBENDREHER TOURNEVIS DESTORNILLADORES	 <b>112-135</b>	<b>POWER TOOL ACCESSORIES</b> ELEKTROWERKZEUGE - ZUBEHÖR ACCESSOIRES POUR OUTILS ÉLECTRIQUES ACCESORIOS PARA HERRAMIENTAS MOTORIZADAS
 <b>48-57</b>	<b>ELECTRICIAN'S TOOLS</b> ELEKTRIKERWERKZEUGE AUTRES OUTILS D'ELECTRICIEN HERRAMIENTAS DE ELECTRICISTA	 <b>136-141</b>	<b>WATER SYSTEMS</b> WASSERSYSTEME RÉSEAUX D'ALIMENTATION EN EAU SISTEMAS DE AGUA
 <b>58-75</b>	<b>BUILDING &amp; PLUMBING</b> BAU UND SANITÄRINSTALLATION BÂTIMENT ET PLOMBERIE CONSTRUCCIÓN Y FONTANERÍA	 <b>142-172</b>	<b>ESD &amp; PRECISION</b> ESD- & PRÄZISIONSWERKZEUGE OUTILS DE PRÉCISION & ESD ESD Y HERRAMIENTAS DE PRECISIÓN
 <b>76-85</b>	<b>MEASURING &amp; MARKING</b> MESSEN & MARKIEREN MESURE & MARQUAGE MEDICIÓN Y MARCADO	 <b>173-176</b>	<b>POINT OF SALE</b> VERKAUFSBEREICH MATERIAL PLV PUNTO DE VENTA
 <b>86-93</b>	<b>SAWING &amp; CUTTING</b> SÄGEN & SCHNEIDEN SCIAGE ET DÉCOUPE ASERRADO Y CORTADO	 <b>177-180</b>	<b>MERCHANDISING</b> ABSATZFÖRDERUNG MERCHANDISING COMERCIALIZACIÓN
 <b>94-103</b>	<b>SOCKETS, SPANNERS &amp; WRENCHES</b> STECKSCHLÜSSEL & SCHRAUBENSCHLÜSSEL DOUILLES ET CLÉS CASQUILLOS, LLAVES DE TUERCAS Y LLAVES INGLESAS	 <b>181-188</b>	<b>INDICES &amp; ICON KEY</b> INDEX & LEGENDE INDEX ET LÉGENDES INDICE E ICONOS

**REDLINE VDE**

REDLINE VDE  
REDLINE VDE  
REDLINE VDE

**8-13**

**REDLINE**

REDLINE  
REDLINE  
REDLINE

**14-16**

**CLASSIC**

CLASSIC  
CLASSIC  
CLASSIC

**17-18**

**WATERPUMP PLIERS**

WASSERPUMPENZANGEN  
PINCES MULTIPRISES  
LLAVES CORREDIZAS

**18-19**

**CRIMPING PLIERS**

CRIMPZANGEN  
PINCES À SERTIR  
ALICATES PARA ENGASTADO

**20-22**

**CIRCLIP PLIERS**

SICHERUNGSRINGZANGEN  
PINCES À CIRCLIPS  
ALICATES DE SUJECIÓN

**23**

**RIVETING PLIERS & RIVETS**

BLINDNIETZANGEN UND NIETEN  
PINCES À RIVETER ET RIVETS  
ALICATES DE REMACHE Y REMACHES

**24-25**

**PVC CUTTERS**

PVC-SCHNEIDER  
PINCES COUPANTES POUR PVC  
ALICATES DE CORTE PVC

**25**

**PINCERS & TOP CUTTERS**

KNEIFZANGEN UND VORNSCHNEIDER  
TENAILLES ET PINCES COUPANTES DEVANT  
PINZAS Y ALICATES DE CORTE

**26**

**HEAVY DUTY CUTTERS**

KRAFTSEITENSCHNEIDER  
PINCES COUPANTES HAUTES PERFORMANCES  
ALICATES DE CORTE PARA TRABAJOS PESADOS

**27**

# PLIERS & CUTTERS

ZANGEN SCHNEIDWERKZEUGE  
PINCES  
ALICATES Y CORTADORES



# REDLINE VDE

## PREMIUM QUALITY SAFETY PLIERS & CUTTERS

VDE / 1000V ISOLIERTE ZANGEN - PREMIUM QUALITÄT  
 PINCES VDE DE QUALITÉ PREMIUM  
 ALICATES Y ALICATES DE CORTE DE SEGURIDAD DE ALTA CALIDAD



**1 Two component, ergonomic design, with anti-slip horns for increased comfort, control & safety**

Zwei-Komponentengriffe, ergonomisches Design, mit Abgleitschutz für höheren Komfort, bessere Handhabung und Sicherheit  
 Manches bicomposant de conception ergonomique avec épaulements antidérapants pour un confort accru, une meilleure maîtrise de l'outil et plus de sécurité  
 Mango de diseño ergonómico de dos componentes y soportes antideslizantes para mayor comodidad, control y seguridad

**2 Induction hardened jaws for outstanding long term performance**

Induktionsgehärtete Schneiden für überragend langlebige Funktion  
 Mâchoires trempées par induction pour une efficacité remarquable sur la durée  
 Mordazas endurecidas por inducción para un excelente rendimiento duradero

**3 Cutting jaws with C.K optimised geometry for unsurpassed cutting performance**

Schneiden mit von C.K optimierter Geometrie für unübertroffene Schneidleistung  
 Mâchoires coupantes dotées de la géométrie optimisée C.K pour un rendement de coupe imbattable  
 Mordazas de corte con una geometría optimizada de C.K para conseguir un rendimiento de corte insuperable

**4 Special alloy steel, drop forged, hardened & tempered for exceptional strength & durability**

Legierter Spezialstahl, gesenkgeschmiedet, gehärtet und angelassen für außerordentliche Festigkeit und Langlebigkeit  
 Acier allié spécial, matricé, trempé et revenu pour une résistance et une durabilité exceptionnelles  
 Acero de aleación especial, forjado, endurecido y templado para una resistencia y durabilidad excepcionales

**5 VDE approved - individually tested to 10,000V for safe live working up to 1,000v**

VDE-zertifiziert - individuell getestet mit 10.000 V für sicheres Arbeiten bis zu 1.000 V  
 Homologation VDE - outils testés individuellement à 10 000 V pour garantir une utilisation en toute sécurité sur des équipements sous tension jusqu'à 1 000 V  
 VDE aprobado - testados individualmente a 10.000 V para la seguridad durante el trabajo hasta 1.000 V

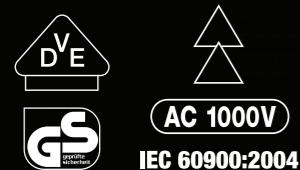

# RedLine VDE™

Conforms to IEC 60900:2004. Approved and independently audited by the German VDE institute.

Entspricht der Norm IEC 60900:2004. Zugelassen und unabhängig geprüft durch das deutsche VDE-Institut.  
 Conformité à la norme CEI 60900:2004. Outils homologués et vérifiés de manière indépendante par l'institut allemand VDE.  
 Cumple con la norma IEC 60900:2004. Aprobados y auditados de forma independiente por el instituto alemán VDE.

# COMBICUTTER

## IT STRIPS, IT BENDS, IT SHEARS

ABISOLIEREN, BIEGEN, ABSCHEREN  
 DÉNUDE, CINTRE, CISAILLE  
 PELA, DOBLA Y CORTA



Specially designed for electrical installation work, these award winning cutters have transformed the way in which electricians work and have become the number one choice of professionals.

Die speziell für elektrische Installationsarbeiten entwickelten und auch prämierten Seitenschneider sind inzwischen die erste Wahl bei Elektrikern.

Spécialement conçues pour les travaux d'installation électrique, ces pinces coupantes primées ont transformé la façon dont les électriciens travaillent et sont devenues le choix numéro un des professionnels.

Diseñados especialmente para trabajos de instalación eléctrica, estos galardonados alicates cortadores han transformado la forma de trabajar de los electricistas y se han convertido en la opción número uno de los profesionales.

### IT STRIPS

ABISOLIEREN  
 DÉNUDE  
 PELA



Wire stripping notches - for effortless and damage free stripping of 1.5 and 2.5mm<sup>2</sup> wire.

Abisolierennuten - für müheloses und beschädigungsfreies Abisolieren von Drahtquerschnitten von 1,5 und 2,5 mm<sup>2</sup>.

Encoches à dénuder - pour dénuder sans peine et sans dommages les fils de 1,5 et 2,5 mm<sup>2</sup>

Muecas para pelar cables sin esfuerzo y sin producir daños al pelar cables de 1,5 y 2,5 mm<sup>2</sup>.

### IT BENDS

BIEGEN  
 CINTRE  
 DOBLA



Wire bending anvil - for quick and damage free doubling back of copper wire.

Drahtbiegeamboss für schnelles und beschädigungsfreies Dublieren von Kupferdrähten.

Contre-outil de cintrage des fils - pour rabattre rapidement et sans dommages les fils de cuivre.

Yunque para doblar el cable a fin de conseguir un doblado del cable de cobre rápido y sin causar daños.

### IT SHEARS

ABSCHEREN  
 CISAILLE  
 CORTA



Patress screw shear - for damage free cutting of patress screws.

Abscherfunktion für beschädigungsfreies Abscheren von 3,5-mm-Steckdosenschrauben.

Cisailage des vis - pour couper sans dommages les vis de boîtes d'encastrement de 3,5 mm.

Cortatornillos incorporado para conseguir un corte sin causar daños para tornillos de 3,5 mm.

REDLINE VDE

- Patress screw shear for damage free cutting of 3.5mm patress screws



VDE combicutter1™

EN 60900, ISO 5749, VDE0682/201, ASTM-F 1505

Item Number	Length	Wire Stripping	Wire Bending	Patress Screw Shear	Quantity
431004	160mm 6"	2.0mm	2.8mm	>4.0mm	3

- Patress screw shear for damage free cutting of 3.5mm patress screws & 4mm conduit cover screws



VDE combicutter1 MAX™

EN 60900, VDE0682/201, ASTM-F 1505

Item Number	Length	Wire Stripping	Wire Bending	Patress Screw Shear	Quantity
T39071-1180	180mm 7"	2.5mm	3.0mm	>4.0mm	3

- Wire stripping notches for effortless & damage free stripping of 1.5 & 2.5mm<sup>2</sup> wire
- Patress screw shear for damage free cutting of 3.5mm patress screws



VDE combicutter2™

EN 60900, ISO 5749, VDE0682/201, ASTM-F 1505

Item Number	Length	Wire Stripping	Wire Bending	Patress Screw Shear	Quantity
431009	160mm 6"	2.0mm	2.8mm	>4.0mm	3

- Wire stripping notches for effortless & damage free stripping of 1.5 & 2.5mm<sup>2</sup> wire
- Wire bending anvil for quick & damage free doubling back of copper wire
- Patress screw shear for damage free cutting of 3.5mm patress screws



VDE combicutter3™

EN 60900, ISO 5749, VDE0682/201, ASTM-F 1505

Item Number	Length	Wire Stripping	Wire Bending	Patress Screw Shear	Quantity
431008	160mm 6"	2.0mm	2.8mm	>4.0mm	3

- Wire stripping notches for effortless & damage free stripping of 1.5 & 2.5mm<sup>2</sup> wire
- Wire bending anvil for quick & damage free doubling back of copper wire
- Patress screw shear for damage free cutting of 3.5mm patress screws & 4mm conduit cover screws.



VDE combicutter3 MAX™

EN 60900, VDE0682/201, ASTM-F 1505

Item Number	Length	Wire Stripping	Wire Bending	Patress Screw Shear	Quantity
T39071-3180	180mm 7"	2.5mm	3.0mm	>4.0mm	3

- Wire stripping notches for effortless & damage free stripping of 1.5 & 2.5mm<sup>2</sup> wire



VDE Side cutters - Wire stripping

EN 60900, ISO 5749, VDE0682/201, ASTM-F 1505

Item Number	Length	Wire Stripping	Wire Bending	Patress Screw Shear	Quantity
431019	160mm 6"	2.0mm	2.8mm	>4.0mm	3



VDE Side cutters - Standard

EN 60900, ISO 5749, VDE0682/201, ASTM-F 1505

Item Number	Length	Wire Stripping	Wire Bending	Patress Screw Shear	Quantity
431017	160mm 6"	2.0mm	2.8mm	>4.0mm	3
431005	180mm 7"	2.5mm	3.0mm	>4.0mm	3

- High leverage design for increased cutting capacity



VDE Side cutters - High leverage

EN 60900, ISO 5749, VDE0682/201, ASTM-F 1505

Item Number	Length	Wire Stripping	Wire Bending	Patress Screw Shear	Quantity
431006	165mm 6½"	2.2mm	3.8mm	>6.0mm	3
431007	200mm 8"	2.5mm	4.2mm	>6.0mm	3

- Shearing action for clean cut results
- Razor sharp, parrot beak blades for effortless cuts
- Suitable for copper & aluminium wire only



VDE Cable cutters

EN 60900, VDE0682/201, ASTM-F 1505

Item Number	Length	Wire Stripping	Wire Bending	Patress Screw Shear	Quantity
431030	160mm 6"	16.0mm		3	

- Shearing action for clean cut results
- Razor sharp, parrot beak blades for effortless cuts
- Suitable for copper & aluminium wire only



VDE Cable cutters

EN 60900, VDE0682/201, ASTM-F 1505

Item Number	Length	Wire Stripping	Wire Bending	Patress Screw Shear	Quantity
431031	210mm 8¼"	20.0mm		3	





## VDE ELECTRICIAN'S PLIERS

1 Tapered nose - streamlined for better access, and ideal for gripping nuts and cutting wires in recessed cabinets



2 Gutter nut holder - specially profiled jaw for securely holding square nuts used on cable trays and cabinets



3 Pin holder - machined at 90° to the angled face for holding cable clips/nails upright while hammering



### VDE Electrician's pliers

EN 60900, VDE0682/201, ASTM-F 1505



Item Number	Length	Wire Size	Wire Size	Wire Size	Wire Size
T39077-180	180mm 7"	1.6mm	2.5mm	>4.0mm	3



- Precision engineered jaws for exceptional grip
- Extra long cutting edges for increased cutting capacity



### VDE Combination pliers

EN 60900, ISO 5746, VDE0682/201, ASTM-F 1505



Item Number	Length	Wire Size	Wire Size	Wire Size	Wire Size
431001	165mm 6"	1.6mm	2.5mm	>4.0mm	3
431002	185mm 7"	1.6mm	2.5mm	>4.0mm	3
431003	205mm 8"	2.0mm	2.8mm	>4.0mm	3

- Serrated inside jaws for secure gripping



### VDE Snipe nose pliers - Straight

EN 60900, ISO 5745, VDE0682/201, ASTM-F 1505



Item Number	Length	Wire Size	Wire Size	Wire Size	Wire Size
431013	175mm 6½"	1.4mm	2.0mm	>4.0mm	3
431014	200mm 8"	1.6mm	2.0mm	>4.0mm	3

- Serrated inside jaws for secure gripping
- Bent nose for special access needs



### VDE Snipe nose pliers - Bent

EN 60900, ISO 5745, VDE0682/201, ASTM-F 1505



Item Number	Length	Wire Size	Wire Size	Wire Size	Wire Size
431015	200mm 8"	1.6mm	2.5mm	>4.0mm	3

- Micro adjustment for damage free repeatable results
- Spring assisted opening for convenience



### VDE Wire stripping pliers

EN 60900, VDE0682/201, ASTM-F 1505



Item Number	Length	Wire Size	Wire Size
431012	160mm 6"	0.3 - 5.0mm	3

CONTENTS: Combination pliers 180mm. Combicutter 160mm. Snipe nose pliers 200mm.



### VDE Pliers Set - 3 Piece



Item Number	Quantity
T3805	1

# REDLINE

## PREMIUM QUALITY PLIERS & CUTTERS

STANDARD ZANGEN - PREMIUM QUALITÄT  
PINCES DE PREMIÈRE QUALITÉ  
ALICATES Y ALICATES DE CORTE DE ALTA CALIDAD



### 1 Two component, ergonomic design, with anti-slip horns for increased comfort, control & safety

Zwei-Komponentengriffe, ergonomisches Design, mit Abgleitschutz für höheren Komfort, bessere Handhabung und Sicherheit  
Manches bicomposant de conception ergonomique avec épaulements antidérapants pour un confort accru, une meilleure maîtrise de l'outil et plus de sécurité  
Diseño ergonómico con dos componentes y soportes antideslizantes para mayor comodidad, control y seguridad

### 2 Induction hardened jaws for outstanding long term performance

Induktionsgehärtete Schneiden für überragend langlebige Funktion  
Mâchoires trempées par induction pour une efficacité remarquable sur la durée  
Mordazas endurecidas por inducción para un excelente rendimiento duradero

### 3 Cutting jaws with C.K. optimised geometry for unsurpassed cutting performance

Schneiden mit von C.K. optimierter Geometrie für unübertroffene Schneidleistung  
Mâchoires coupantes dotées de la géométrie optimisée C.K. pour un rendement de coupe imbattable  
Mordazas de corte con una geometría optimizada de C.K. para conseguir un rendimiento de corte insuperable

### 4 Special alloy steel, drop forged, hardened & tempered for exceptional strength & durability

Legierter Spezialstahl, gesenkgeschmiedet, gehärtet und angelassen für außerordentliche Festigkeit und Langlebigkeit  
Acier allié spécial, matricé, trempé et revenu pour une résistance et une durabilité exceptionnelles  
Acero de aleación especial, forjado, endurecido y templado para una resistencia y durabilidad excepcionales



RedLine™

## REDLINE



### Side cutters - Standard

ISO 5749

Item Number	Length	Wire	Tube	Sheet	Box
T3750 145	140mm 5½"	1.4mm	1.9mm	>4.0mm	3
T3750 160	160mm 6"	2.0mm	2.8mm	>4.0mm	3
T3750 180	180mm 7"	2.5mm	3.0mm	>4.0mm	3

- High leverage design for increased cutting capacity



### Side cutters - High leverage

ISO 5749

Item Number	Length	Wire	Tube	Sheet	Box
T3720 65	165mm 6½"	2.2mm	3.8mm	>6.0mm	3
T3720 8	200mm 8"	2.5mm	4.2mm	>6.0mm	3

- Shearing action for clean cut results
- Razor sharp, parrot beak blades for effortless cuts
- Suitable for copper & aluminium wire only



### Cable cutters

Item Number	Length	Wire	Box
T3964 6	160mm 6½"	16.0mm	3

- Precision engineered jaws for exceptional grip
- Extra long cutting edges for increased cutting capacity



### Combination pliers

ISO 5746

Item Number	Length	Wire	Tube	Sheet	Box
T3867 6	160mm 6"	1.6mm	2.5mm	>4.0mm	3
T3867 7	180mm 7"	1.6mm	2.5mm	>4.0mm	3
T3867 8	200mm 8"	2.0mm	2.8mm	>4.0mm	3

- Serrated inside jaws for secure gripping



### Snipe nose pliers - Straight

ISO 5745

Item Number	Length	Wire	Tube	Sheet	Box
T3909 5	140mm 5½"	1.2mm	1.6mm	>4.0mm	3
T3909 6	170mm 6¾"	1.4mm	1.9mm	>4.0mm	3
T3906 8	200mm 8"	1.6mm	2.0mm	>4.0mm	3

- Serrated inside jaws for secure gripping
- Bent nose for special access needs



### Snipe nose pliers - Bent

ISO 5745

Item Number	Length	Wire	Tube	Sheet	Box
T3907 8	200mm 8"	1.6mm	2.0mm	>4.0mm	3



- Micro adjustment for damage free repeatable results
- Spring assisted opening for convenience



### Wire stripping pliers

ISO 5743

Item Number	Length	Capacity	Quantity
T3754	160mm 6"	0.3 - 5.0mm	3

CONTENTS: Combination pliers 180mm. Side cutters 160mm. Snipe nose pliers 200mm.



### Pliers set - 3 Piece

Item Number	Quantity
T3803	1

CONTENTS: Wire stripping pliers 160mm. Side cutters 160mm. Snipe nose pliers 200mm.



### Pliers set - 3 Piece

Item Number	Quantity
T3804	1

# CLASSIC PROFESSIONAL GENERAL PURPOSE PLIERS & CUTTERS



PROFESSIONELLE UNIVERSAL-ZANGEN  
 PINCES PROFESSIONNELLES A USAGE UNIVERSEL  
 ALICATES Y ALICATES DE CORTE DE USO GENERAL PARA PROFESIONALES

- 1 Induction hardened jaws for outstanding long term performance**  
 Induktionsgehärtete Schneiden für überragend langlebige Funktion  
 Mâchoires trempées par induction pour une efficacité remarquable sur la durée  
 Mordazas endurecidas por inducción para un excelente rendimiento duradero
- 2 High alloy steel, drop forged, hardened & tempered for exceptional strength & durability**  
 Hochlegierter Stahl, gesenkgeschmiedet, gehärtet und angelassen für außerordentliche Festigkeit und Langlebigkeit.  
 Acier fortement allié, matricé, trempé et revenu pour une résistance et une durabilité exceptionnelles  
 Acero de alta aleación, forjado, endurecido y templado para una resistencia y durabilidad excepcionales
- 3 Heads polished and lacquered for corrosion protection**  
 Köpfe für Korrosionsschutz poliert und lackiert  
 Têtes polies et laquées pour la protection contre la corrosion  
 Cabezales pulidos y barnizados para proteger contra la corrosión
- 4 Wipe clean PVC handles for added convenience**  
 PVC-Griffe können durch einfaches Abwischen sehr leicht gereinigt werden  
 Manches PVC faciles à nettoyer pour un plus grand confort d'utilisation  
 Mangos de PVC de fácil limpieza para mayor comodidad



Classic™

CLASSIC



Side cutters - Standard

ISO 5749

Item Number	Length	Jaw Width	Tip Width	Tip Length	Quantity
T3623B 5	140mm 5½"	1.2mm	1.6mm	>4.0mm	6
T3623B 6	160mm 6"	1.6mm	2.1mm	>4.0mm	6

- High leverage design for increased cutting capacity



Side cutters - High leverage

ISO 5749

Item Number	Length	Jaw Width	Tip Width	Tip Length	Quantity
T3627B 7	180mm 7"	2.2mm	3.8mm	>6.0mm	6

- Precision engineered jaws for exceptional grip
- Extra long cutting edges for increased cutting capacity



Combination pliers

ISO 5746

Item Number	Length	Jaw Width	Tip Width	Tip Length	Quantity
T3621B 6	160mm 6"	1.6mm	2.5mm	>4.0mm	6
T3621B 7	180mm 7"	1.6mm	2.5mm	>4.0mm	6
T3621B 8	200mm 8"	2.0mm	2.8mm	>4.0mm	6

- Serrated inside jaws for secure gripping



Snipe nose pliers - Straight

ISO 5745

Item Number	Length	Jaw Width	Tip Width	Tip Length	Quantity
T3622B	140mm 5½"	1.4mm	1.9mm	>4.0mm	6
T3626B 8	200mm 8"	1.6mm	2.0mm	>4.0mm	6

WATERPUMP PLIERS

- Special alloy steel, drop forged, hardened & tempered for exceptional strength & durability
- Induction hardened jaws for outstanding long term performance
- 'Slide to adjust' mechanism for fast & accurate size adjustment
- Slim head & jaws for access to confined spaces
- Contoured anti-slip handles for comfortable & powerful operation



Waterpump pliers - Speedlok

DIN ISO 8976

Item Number	Length	Jaw Width	Quantity
T3655 250	250mm 10"	38mm 1½"	6
T3655 300	300mm 12"	55mm 2"	6

- Special alloy steel, drop forged, hardened & tempered for exceptional strength & durability
- Induction hardened jaws for outstanding long term performance
- Box joint design with double pivot support for strength
- Slim head & jaws for access to confined spaces
- Contoured anti-slip handles for comfortable & powerful operation



Waterpump pliers - Heavy duty

DIN 8976

Item Number	Length	Jaw Width	Quantity
T3659A 175	180mm 7"	25mm 1"	3
T3659A 240	240mm 9½"	32mm 1¼"	3
T3659A 300	300mm 12"	45mm 1¾"	3
T3659A 400	400mm 16"	64mm 2½"	1



Waterpump pliers - Standard

DIN ISO 8976

Item Number	Length	Jaw Width	Quantity
T3651 09	250mm 10"	38mm 1½"	3

- Special alloy steel, drop forged, hardened & tempered for exceptional strength & durability
- Induction hardened jaws for outstanding long term performance
- Self adjusting jaws for optimised grip & pressure
- Push button adjustment for convenient size setting
- Contoured anti-slip handles for comfortable & powerful operation



Pliers wrench

Item Number	Length	Wrench Size	Wrench Width	Wrench Depth	Quantity
T3656 250	250mm 10"	20mm	36mm / M24	53mm	3



# RATCHET CRIMPING PLIERS

## RATSCHEN-CRIMPZANGEN

### PINCES À SERTIR À CLIQUET

#### ALICATES PARA ENGASTAR CON TRINQUETE



#### 1 Auto-stop ratchet system releases when correct pressure is applied to ensure precise crimping

Ratschensystem mit automatischer Schnellauslösung, die beim Erreichen des korrekten Andrucks die Zange wieder freigibt, um präzises Crimpen zu gewährleisten

Le système de cliquet à arrêt automatique débraye dès que la pression correcte est appliquée afin d'assurer un sertissage précis

El sistema de parada automática del trinquete se activa cuando se aplica la presión adecuada para garantizar un engaste preciso

#### 2 Precision engineered dies for quality crimps and safe connections

Präzise bearbeitete Quetschbacken für qualitatives Crimpen und sichere Verbindungen

Matrices à usinage de précision pour des sertissages de qualité et des connexions sûres

Matrices con ingeniería de precisión para conseguir engastes de calidad y conexiones seguras

#### 3 Dies manufactured from fully hardened carbon alloy steel for strength & durability

Aus voll gehärtetem, legiertem Kohlenstoffstahl für Festigkeit und Langlebigkeit

Matrices en acier allié au carbone entièrement trempé, garantissant résistance et durabilité

Matrices fabricadas en acero de aleación al carbono totalmente endurecido para mayor resistencia y durabilidad

#### 4 Heavy duty construction, tested up to 40,000 cycles, guaranteed for 30,000 crimps per tool

Sehr robust, bis zu 40.000 Anwendungen getestet, 30.000 Vorgänge werden garantiert

Construction robuste, testée jusqu'à 40 000 cycles, garantie pour 30 000 sertissages par outil

Construcción resistente, testada con 40.000 ciclos, garantizando 30.000 remaches por herramienta

#### 5 Ergonomic design for increased comfort & control

Ergonomisches Design für erhöhten Komfort und bessere Bedienung

Conception ergonomique pour un confort accru et une meilleure maîtrise de l'outil

Diseño ergonómico para mayor comodidad y control



## CRIMPING PLIERS

- Designed for the safe & secure crimping of boot lace ferrules



### Ratchet crimping pliers - Small ferrules

Item Number	Icon	Length	mm <sup>2</sup> /AWG	Box
430018		190mm	0.14 - 2.5 / 26 - 14	3

- Designed for the safe & secure crimping of boot lace ferrules



### Ratchet crimping pliers - Medium ferrules

Item Number	Icon	Length	mm <sup>2</sup> /AWG	Box
430029		190mm	0.25 - 6.0 / 20 - 10	3

- Designed for the safe & secure crimping of boot lace ferrules



### Ratchet crimping pliers - Large ferrules

Item Number	Icon	Length	mm <sup>2</sup> /AWG	Box
430022		230mm	10 - 25 / 8 - 3	3

- Designed for the safe & secure crimping of bell mouth ferrules



### Ratchet crimping pliers - Non-insulated terminals

Item Number	Icon	Length	mm <sup>2</sup> /AWG	Box
T3676		350mm	6 - 25 / 10 - 4	3

- Designed for the safe & secure crimping of red, blue or yellow insulated terminals



### Ratchet crimping pliers - Insulated terminals

Item Number	Icon	Length	mm <sup>2</sup> /AWG	Box
430021		220mm	0.5 - 6.0 / 20 - 10	3

- Designed for the safe & secure crimping of non insulated terminals



### Ratchet crimping pliers - Non-insulated terminals

Item Number	Icon	Length	mm <sup>2</sup> /AWG	Box
430025		230mm	1.5 - 10 / 16 - 8	3

- Designed for the safe & secure crimping of BNC/TNC connectors to coaxial cable



### Ratchet crimping pliers - Coax, BNC, TNC

Item Number	Length	Info	Box
430026	230mm	For: 58, 59, 62, 8X, 140, 141, 174, 210, 223, 303, 400.	3

- Designed for the safe & secure attachment of modular plugs without die changes
- Built in wire stripper/cutter mechanism for convenience.



### Ratchet crimping pliers - Modular plugs 1

Item Number	Length	Info	Box
430020	220mm	4P2C, 4P4C, 6P4C (RJ11), 6P6C (RJ12), 8P8C (RJ45) and 6P6C/Offset	3

- Designed for the safe & secure attachment of modular plugs without die changes
- Built in wire stripper/cutter mechanism for convenience



### Ratchet crimping pliers - Modular plugs 2

Item Number	Length	Info	Box
430028	250mm	8P8C (RJ-45) 6P6C (RJ-12) and 6P4C (RJ-11)	3

- Designed for the safe & secure crimping of boot lace ferrules
- Hardened & tempered high alloy carbon steel for increased strength & durability
- Matt chrome plated for corrosion protection
- Contoured grips with anti-slip horns for comfort & safety



### Crimping plier - Small ferrules

Item Number	Length	mm <sup>2</sup> /AWG	Box
430005	145mm	0.25 - 2.5 / 23 - 13	3

- Designed for the safe & secure crimping of boot lace ferrules
- Hardened & tempered high alloy carbon steel for increased strength & durability
- Matt chrome plated for corrosion protection
- Contoured grips with anti-slip horns for comfort & safety



### Crimping plier - Medium ferrules

Item Number	Length	mm <sup>2</sup> /AWG	Box
430006	220mm	0.5 - 16 / 20 - 5	3

## CIRCLIP PLIERS

- Chequered handles for grip



### Circlip pliers - Inside straight

DIN 5256

Item Number	Length	Ø	DIN	Box
T3710 0	140mm 5½"	8 - 13mm	J0	5
T3710 5	140mm 5½"	12 - 25mm	J1	5
T3710 7	180mm 7"	19 - 60mm	J2	5
T3710 8	220mm 8¾"	40 - 100mm	J3	5
T3710 11	300mm 12"	85 - 140mm	J4	5

- Chequered handles for grip



### Circlip pliers - Outside straight

DIN 5256

Item Number	Length	Ø	DIN	Box
T3711 0	140mm 5½"	3 - 10mm	A0	5
T3711 5	140mm 5½"	10 - 25mm	A1	5
T3711 7	180mm 7"	19 - 60mm	A2	5
T3711 8	220mm 8¾"	40 - 100mm	A3	5
T3711 11	300mm 12"	85 - 140mm	A4	5

- Chequered handles for grip



### Circlip pliers - Inside bent

DIN 5256

Item Number	Length	Ø	DIN	Box
T3712 5	140mm 5½"	12 - 25mm	J11	5
T3712 7	180mm 7"	19 - 60mm	J21	5
T3712 8	220mm 8¾"	40 - 100mm	J31	5

- Chequered handles for grip



### Circlip pliers - Outside bent

DIN 5256

Item Number	Length	Ø	DIN	Box
T3713 0	140mm 5½"	3 - 10mm	A01	5
T3713 5	140mm 5½"	10 - 25mm	A11	5
T3713 7	180mm 7"	19 - 60mm	A21	5
T3713 8	220mm 8¾"	40 - 100mm	A31	5

- Push button changeover from inside to outside configuration for convenience

CONTENTS: 1 x adjustable circlip pliers. 1 x inside circlips, sizes: 12, 14, 16, 18, 20 & 22mm. 1 x outside circlips, sizes: 12, 14, 16, 18, 20 & 22mm.



### Circlip pliers set - Adjustable

Item Number	Box
T3716	3

## RIVETING PLIERS & RIVETS

- Heavy duty steel construction for exceptional strength & durability
- Colour coded interchangeable nose bushes for convenience (Nose spanner included)
- 3 jaw mechanism for increased grip and outstanding long term performance – 50% greater gripping strength than a standard 2 jaw riveter
- Ergonomic anti-slip handles for increased comfort



### Riveting pliers

Item Number	Length	Interchangeable nose bushes for setting	Quantity
T3820	260mm 10 1/2"	3.15mm (1/8"), 4mm (5/32"), 4.8mm (3/16") rivets	3

CONTENTS: Riveting pliers. 25 x aluminium rivets, sizes: 1/8" (3.2mm), 5/32" (4.0mm) & 3/16" (4.8mm).



### Riveting pliers set

Item Number	Quantity
T3820AS	1

- Heavy duty steel construction for exceptional strength & durability
- 'Anti shock' design protects from injuries to wrist, arm or shoulder
- Cushion grip handle for superior grip & comfort
- Colour coded interchangeable nose bushes for convenience

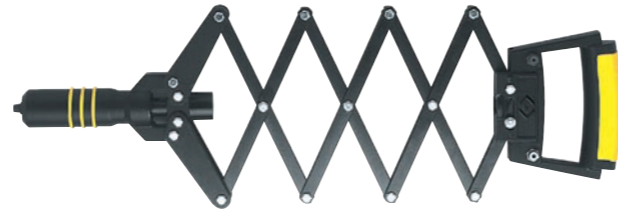

### Lazy tong riveter

Item Number	Length	Interchangeable nose bushes for setting	Quantity
T3822A	305 - 780mm 12" - 32 1/2"	2.4mm (3/32"), 3.15mm (1/8"), 4mm (5/32"), 4.8mm (3/16"), 6mm (1/4") rivets	1

- Colour coded for simple size identification



### Rivets - Aluminium (Pack 50)

Item Number	Length	Interchangeable nose bushes for setting	Quantity
T3819A 408	3.15 x 6mm 1/8 x 1/4"	short	15
T3819A 412	3.15 x 9mm 1/8 x 3/8"	medium	15
T3819A 415	3.15 x 12mm 1/8 x 1/2"	large	15
T3819A 508	4 x 6mm 5/32 x 1/4"	short	15
T3819A 512	4 x 9mm 5/32 x 3/8"	medium	15
T3819A 515	4 x 12mm 5/32 x 1/2"	large	15
T3819A 612	4.8 x 9mm 3/16 x 3/8"	medium	15
T3819A 615	4.8 x 12mm 3/16 x 1/2"	long	15
T3819A 620	4.8 x 16mm 3/16 x 5/8"	ex long	15

- Galvanised steel for corrosion resistance



### Washers - (Pack 100)

Item Number	Length	Quantity
T3824 12	3.15mm 1/8"	15
T3824 15	4mm 5/32"	15
T3824 18	4.8mm 3/16"	15

CONTENTS: 3 x riveting pliers. 3 x riveting pliers sets. 6 x boxes of aluminium rivets (x9 sizes). 6 x boxes of washers (x3 sizes).



### Riveting display stand

Item Number	Dimensions	Quantity
T3825LS	570 x 530 x 330mm	1

## PVC CUTTERS

- Heavy duty aluminium body - Strong & light
- Ratchet action razor sharp stainless steel blade for effortless cutting of; PVC conduit, blue water mains, plastic pipe, rubber hose, pneumatic pipe, electrical sleeving, etc
- Complete with special adaptor for straight or mitre cutting of small rectangular cross-section trunking



### PVC pipe & conduit cutter - Ratchet

Item Number	Length	Blade Width	Quantity
430003	220mm	32mm	3

- Glass fibre reinforced polycarbonate body - Strong & light
- Razor sharp stainless steel blade for efficient cutting of: PVC conduit, blue water mains, plastic pipe, rubber hose, pneumatic pipe, electrical sleeving, etc



### PVC pipe & conduit cutter

Item Number	Length	Blade Width	Quantity
430001	195mm	28mm	3

- Heavy duty aluminium body - Strong & light
- Lever action razor sharp stainless steel blade for effortless cutting of; PVC conduit, blue water mains, plastic pipe, rubber hose, pneumatic pipe, electrical sleeving, wooden dowel, etc
- 5 interchangeable anvils (flat, double radius, single radius, 90° square and mitre) allow a variety of cross sections to be cut, both straight and mitred



### Multi cutter set

Item Number	Quantity
T2240	3

## PINCERS & TOP CUTTERS

- Optimised jaw design for effective gripping & extracting of screws, nails, fixings, etc
- Specially profiled cutting blades for cutting metal rod & wire
- High alloy steel, drop forged, hardened & tempered for exceptional strength & durability
- Wipe clean PVC handles for added convenience
- Black lacquered for corrosion protection



### Pincers

DIN/ISO 9243

Item Number	Length	Tip Width	Tip Thickness	Weight
T4108A 06	160mm 6"	2.0mm	>4.0mm	3
T4108A 07	180mm 7"	2.0mm	>4.0mm	3
T4108A 08	200mm 8"	2.0mm	>4.0mm	3

- Heavy duty construction, drop forged alloy steel, hardened & tempered for exceptional strength & durability
- Induction hardened jaws for outstanding long term performance
- Wipe clean PVC handles for added convenience
- Black lacquered for corrosion protection

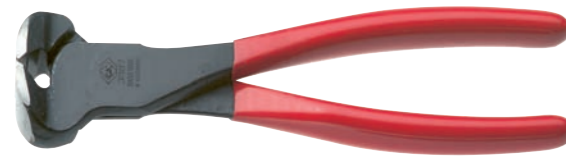

### Top cutter - Heavy duty

DIN/ISO 5748

Item Number	Length	Tip Width	Tip Thickness	Weight	
T3987A 7	180mm 7"	2.5mm	3.2mm	>4.0mm	3

- High alloy steel, drop forged, hardened & tempered for strength & durability
- Induction hardened jaws for outstanding long term cutting performance
- Wipe clean PVC handles for added convenience
- Black lacquered for corrosion protection



### Top cutter - Standard

DIN/ISO 5748

Item Number	Length	Tip Width	Tip Thickness	Weight	
T3988 180	180mm 7"	2.5mm	3.2mm	>4.0mm	3
T3988 200	200mm 8"	2.8mm	3.5mm	>4.0mm	3

- Special slimline design for binding & twisting wire.
- Induction hardened jaws for outstanding long term cutting performance
- High alloy steel, drop forged, hardened & tempered for exceptional strength & durability
- Wipe clean PVC handles for added convenience
- Black lacquered for corrosion protection



### Top cutters - Steel fixers

DIN/ISO 9243

Item Number	Length	Tip Width	Tip Thickness	Weight
T4112A 08	220mm 8½"	2.0mm		3
T4112A 10	250mm 10"	2.0mm		3
T4112A 11	280mm 11"	2.0mm		3

## HEAVY DUTY CUTTERS

- High tensile, special alloy jaws heat treated for cutting hard materials up to 40HRC
- Compound action mechanism applies extreme cutting forces



### Bolt cutters

Item Number	Length	785Nmm <sup>2</sup> (61TONS SQ <sup>2</sup> )	1226Nmm <sup>2</sup> (80TONS SQ <sup>2</sup> )	Weight
T4358 12	340mm 13"	6mm	5mm	1
T4358 15	400mm 16"	7mm	6mm	1
T4358 18	450mm 18"	10mm	7mm	1
T4358 25	610mm 24"	11mm	9mm	1
T4358 30	800mm 31"	13mm	11mm	1
T4358 36	900mm 35"	15mm	13mm	1

- Compact cutters ideal for fencing, meshes and low tensile wire
- Hot drop forged chrome vanadium steel jaws with induction hardened cutting edges for strength and durability
- Compound action mechanism applies extreme cutting forces



### Bolt cutter - Pocket

Item Number	Length	785Nmm <sup>2</sup> (61TONS SQ <sup>2</sup> )	1226Nmm <sup>2</sup> (80TONS SQ <sup>2</sup> )	Weight
T4371A	250mm 10"	5mm	3mm	2

- Heavy duty construction, drop forged alloy steel, hardened & tempered for exceptional strength & durability
- Induction hardened specially profiled shearing blades for clean cutting of a wide range of wire & cables including: bowden cable, steel wire, fencing wire, stranded wire rope, copper & aluminium cables, steel rods, etc
- PVC coated handles for comfort and grip



### Cable & wire rope cutter

Item Number	Length	Tip Width	Tip Thickness	Weight
T3744	190mm	6mm	4mm	3

- Heavy duty construction, drop forged alloy steel, hardened & tempered for exceptional strength & durability
- Induction hardened jaws for outstanding long term performance
- Wipe clean PVC handles for added convenience
- Black lacquered for corrosion protection



### Wire cutters - Heavy duty

Item Number	Length	Tip Width	Tip Thickness	Weight
T3961A 08	200mm 8"	2.0mm		3
T3961A 10	250mm 10"	3.0mm		5

- Specially hardened steel punches and brass anvil for long term cutting performance
- 6 punch revolving head marked with size for convenience
- Black lacquered coating for corrosion protection
- Suitable for leather, plastic, card, etc



### Revolving punch pliers

Item Number	Length	Tip Width	Tip Thickness	Weight
T3817	220mm 8½"	2, 2.5, 3, 3.5, 4, 4.5mm		5

# SCREWDRIVERS

SCHRAUBENDREHER  
TOURNEVIS  
DESTORNILLADORES



## DEXTRO VDE

DEXTRO VDE  
DEXTRO VDE  
DEXTRO VDE

30-33

## DEXTRO

DEXTRO  
DEXTRO  
DEXTRO

34-37

## HD CLASSIC

HD CLASSIC  
HD CLASSIC  
HD CLASSIC

38-41

## TRITON XLS

TRITON XLS  
TRITON XLS  
TRITON XLS

42-45

## MAINSTESTERS

SPANNUNGSPRÜFER  
TESTEURS DE TENSION  
TESTERS

46

## RATCHET SCREWDRIVERS

RATSCHEN-SCHRAUBENDREHER  
TOURNEVIS À CLIQUET  
DESTORNILLADORES CON TRINQUETE

46-47

## IMPACT DRIVER & BITS

SCHLAGSHRAUBER & BITS  
TOURNEVIS À IMPACT & EMBOUTS  
TROQUEL DE IMPACTO Y BROCAS

47

## BRADAWLS

DORNEN  
ALÈNES  
PUNTAS

47



# DEXTRO VDE

## PREMIUM QUALITY SAFETY SCREWDRIVERS

PREMIUMQUALITÄT - SICHERHEITSSCHRAUBENDREHER  
TOURNEVIS VDE DE QUALITÉ PREMIUM  
DESTORNILLADORES DE SEGURIDAD DE ALTA CALIDAD



### 1 Tip type marking for easy identification

Kopf Markierung für einfache Erkennung  
Marquage du type de pointe pour une identification aisée  
Tope superior marcado con el tipo de punta para facilitar su identificación

### 2 Ergonomically shaped, dual component handle for increased comfort, control & safety

Ergonomisch geformt, Zwei-Komponenten Griff für höheren Komfort, bessere Handhabung und Sicherheit  
Manche ergonomique à double composant pour un confort accru, une meilleure maîtrise de l'outil et plus de sécurité  
Mango de dos componentes con forma ergonómica para una mayor comodidad, control y seguridad

### 3 Long fine neck for precise fingertip control

Langer Hals für präzise Führung mit der Fingerspitze  
Corps allongé et fin pour une meilleure maniabilité  
Cuello largo y fino para un control más preciso de los dedos

### 4 Ridges along the head give extra grip in that last 1/4 turn

Kanten entlang dem Kopf bieten zusätzliche Griffigkeit in der letzten 1/4-Umdrehung  
Les arêtes le long de la tête apportent le surplus de préhension nécessaire pour le dernier quart de tour  
Puntas con superficie estructurada que proporcionan un mayor agarre en el último 1/4 de apriete

### 5 Handle injection moulded directly to blade giving the ultimate bond for increased reliability & durability

Direkter Spritzguss des Handgriffs mit dem Schaft ergibt absolute Verbindung für erhöhte Zuverlässigkeit und Dauerhaftigkeit  
Manche moulé par injection directement sur la lame, gage de la meilleure des adhérences pour une fiabilité et une durabilité accrues  
Mango de inyección moldeado directamente en la varilla proporcionando el refuerzo fundamental para una mayor fiabilidad y durabilidad

### 6 VDE approved - individually tested to 10,000v for safe live working up to 1,000v

VDE-Zulassung - individuell getestet mit 10.000v für sicheres Arbeiten bis zu 1.000v  
Homologation VDE - outils testés individuellement à 10.000v pour garantir une utilisation en toute sécurité sur des équipements sous tension jusqu'à 1.000v  
VDE aprobado - testados individualmente a 10.000v para la seguridad durante el trabajo hasta 1.000v

### 7 GRIP-TIP™ anti cam-out ribs reduce the risk of slipping

GRIP-TIP™ Abgleitschutzrippen reduzieren das Risiko des Abrutschens  
Les nervures anti-rejet GRIP-TIP™ réduisent le risque de dérapage de l'outil  
GRIP-TIP™ bordes anticaída para reducir el riesgo de deslizamiento

### 8 Premium quality chrome vanadium steel blade for exceptional strength & durability

Hochqualitativer Chrom-Vanadiumstahlschaft für außergewöhnliche Festigkeit und Dauerhaftigkeit  
Lame en acier au chrome-vanadium de première qualité pour une résistance et une durabilité exceptionnelles  
Cuchilla de acero al cromo vanadio de alta calidad para una resistencia y durabilidad excepcionales

### 9 Precision machined tip for an exact screw fit & damage free screwdriving

Präzise bearbeitete Spitze für exakte Anpassungen an die Schrauben und beschädigungsfreies Eindrehen  
Pointe à usinage de précision pour un logement exact dans la tête de vis et un vissage sans dommages  
Punta mecanizada de precisión para el ajuste exacto del tornillo y sin causar daños al atornillar

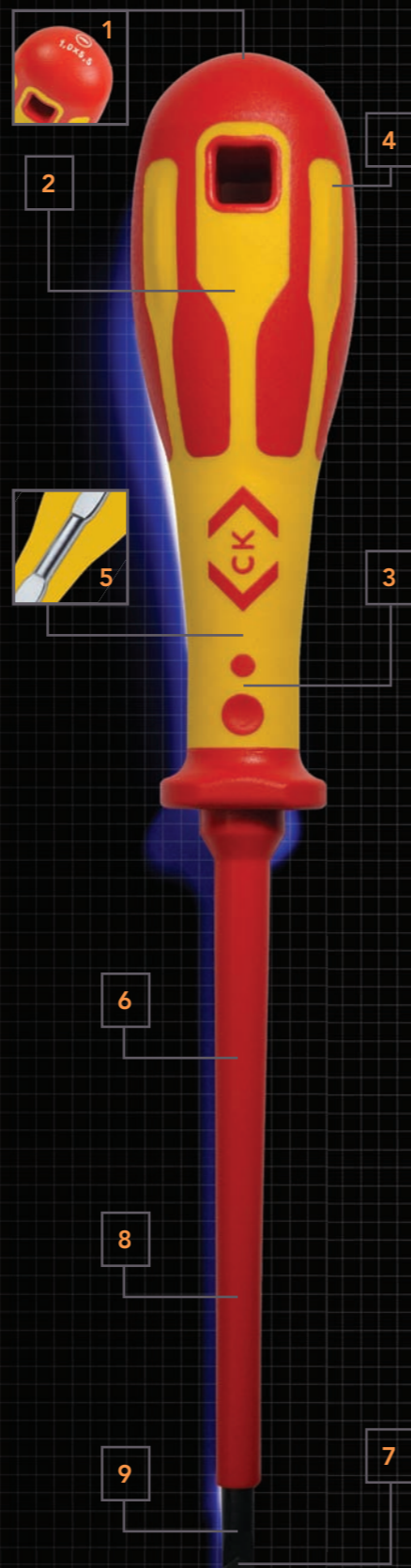

Conforms to IEC 60900:2004. Approved and independently audited by the German VDE institute.

Entspricht der Norm IEC 60900:2004. Zugelassen und unabhängig geprüft durch das deutsche VDE-Institut.  
Conformité à la norme CEI 60900:2004. Outils homologués et vérifiés de manière indépendante par l'institut allemand VDE.  
Cumple con la norma IEC 60900:2004. Aprobados y auditados de forma independiente por el instituto alemán VDE.

featuring GRIP-TIP™ technology

## DEXTRO VDE



### VDE Screwdrivers - Slotted parallel

VDE0682/201, ASTM-F 1505, EN 60900, ISO 2380-2, DIN 5264

Item Number	+	Ø	→	←	⊞
T49144-025	2.5mm 3/32"	75mm 3"	0.4mm 0.016"	95mm 3 3/4"	6
T49144-030	3.0mm 1/8"	100mm 4"	0.5mm 0.020"	95mm 3 3/4"	6
T49144-035	3.5mm 9/64"	100mm 4"	0.6mm 0.024"	95mm 3 3/4"	6
T49144-040	4.0mm 1/2"	100mm 4"	0.8mm 0.031"	107mm 4 1/2"	6
T49144-055	5.5mm 7/32"	125mm 5"	1.0mm 0.039"	120mm 4 3/4"	6
T49144-065	6.5mm 1/4"	150mm 6"	1.2mm 0.047"	120mm 4 3/4"	6
T49144-080	8.0mm 5/16"	175mm 7"	1.2mm 0.047"	135mm 5 1/8"	6
T49144-100	10.0mm 25/64"	200mm 8"	1.6mm 0.063"	135mm 5 1/8"	6



### VDE Screwdrivers - PZ

VDE0682/201, ASTM-F 1505, EN 60900, ISO 8764

Item Number	+	Ø	→	←	⊞
T49143-0	PZ0	3.5mm 9/64"	60mm 2 3/8"	95mm 3 3/4"	6
T49143-1	PZ1	5.0mm 3/16"	80mm 3 1/8"	107mm 4 1/2"	6
T49143-2	PZ2	6.0mm 15/64"	100mm 4"	107mm 4 1/2"	6
T49143-2200	PZ2	6.0mm 15/64"	200mm 8"	120mm 4 3/4"	6
T49143-3	PZ3	8.0mm 5/16"	150mm 6"	135mm 5 1/8"	6



### VDE Screwdrivers - PH

VDE0682/201, ASTM-F 1505, EN 60900, ISO 8764

Item Number	+	Ø	→	←	⊞
T49142-0	PH0	3.5mm 9/64"	60mm 2 3/8"	95mm 3 3/4"	6
T49142-1	PH1	5.0mm 3/16"	80mm 3 1/8"	107mm 4 1/2"	6
T49142-2	PH2	6.0mm 15/64"	100mm 4"	120mm 4 3/4"	6
T49142-3	PH3	8.0mm 5/16"	150mm 6"	135mm 5 1/8"	6



### VDE Screwdriver - Modulo

VDE0682/201, ASTM-F 1505, EN 60900

Item Number	+	Ø	→	←	⊞
T49145-1	1	5.0mm 3/16"	80mm 3 1/8"	107mm 4 1/2"	6
T49145-2	2	6.0mm 15/64"	100mm 4"	120mm 4 3/4"	6

CONTENTS: 1 x modulo, sizes: 1 x 80 & 2 x 100mm.



### VDE Screwdriver set - Modulo

VDE0682/201, ASTM-F 1505, EN 60900

Item Number	+	⊞
T49146	1 & 2	1



CONTENTS: 1 x slotted parallel, sizes: 2.5 x 75, 4.0 x 100 & 5.5 x 125mm. 1 x PZ, sizes: 1 x 80 & 2 x 100mm. Mainstester.



**VDE Screwdriver set -  
6 Piece SL/PZ**

VDE0682/201, ASTM-F 1505, EN 60900



Item Number	
T49183	1

CONTENTS: 1 x slotted parallel, sizes: 2.5 x 75, 4 x 100 & 5.5 x 125mm. 1 x PH, sizes: 1 x 80 & 2 x 100mm. Mainstester.



**VDE Screwdriver set -  
6 Piece SL/PH**

VDE0682/201, ASTM-F 1505, EN 60900



Item Number	
T49182	1

CONTENTS: 1 x slotted parallel, sizes: 2.5 x 75, 4.0 x 100, 5.5 x 125 & 6.5 x 150mm. 1 x PZ, sizes: 0 x 60, 1 x 80 & 2 x 100mm. Mainstester.



**VDE Screwdriver set -  
8 Piece SL/PZ**

VDE0682/201, ASTM-F 1505, EN 60900



Item Number	
T49193	1

CONTENTS: 1 x slotted parallel, sizes: 2.5 x 75, 4 x 100, 5.5 x 125 & 6.5 x 150mm. 1 x PH, sizes: 0 x 60, 1 x 80 & 2 x 100mm. Mainstester.



**VDE Screwdriver set -  
8 Piece SL/PH**

VDE0682/201, ASTM-F 1505, EN 60900



Item Number	
T49192	1

CONTENTS: 6 x slotted parallel, sizes: 2.5 x 75, 3 x 100, 4 x 100, 5.5 x 125 & 6.5 x 150mm. 6 x PZ, sizes: 0 x 60, 1 x 80, 2 x 100 & 2 x 200mm. 6 x PH, sizes: 1 x 80 & 2 x 100mm.



**Top sellers display**

Item Number		
DEXTROVDE-TS	stock, shelf & header	1

- Optional countertop Z-frame available



**Countertop Z-frame**

Item Number	
M0162	1

CONTENTS: 12 x slotted parallel, sizes: 2.5 x 75, 3.0 x 100 & 4.0 x 100mm. 6 x slotted parallel, sizes: 3.5 x 100, 5.5 x 125, 6.5 x 150, 8.0 x 175 & 10.0 x 200mm.



**Full range display -  
Shelf 1**

Item Number		
DEXTROVDE-S1	stock, shelf & header	1

CONTENTS: 6 x PZ, sizes: 0 x 60, 1 x 80, 2 x 100, 2 x 200 & 3 x 150mm. 6 x PH, sizes: 0 x 60, 1 x 80, 2 x 100 & 3 x 150mm. 6 x modulo, sizes: 1 x 75 & 2 x 100mm.

**Shelf 2**

Item Number		
DEXTROVDE-S2	stock, shelf & header	1

# DEXTRO PREMIUM QUALITY SCREWDRIVERS

PREMIUMQUALITÄT - SCHRAUBENDREHER  
TOURNEVIS DE QUALITÉ PREMIUM  
DESTORNILLADORES DE ALTA CALIDAD



## 1 Tip type marking for easy identification

Kopf Markierung für einfache Erkennung  
Marquage du type de pointe pour une identification aisée  
Tope superior marcado con el tipo de punta para facilitar su identificación

## 2 Ergonomically shaped, dual component handle for increased comfort, control & safety

Ergonomisch geformt, Zwei-Komponenten Griff für höheren Komfort, bessere Handhabung und Sicherheit  
Manche ergonomique à double composant pour un confort accru, une meilleure maîtrise de l'outil et plus de sécurité  
Doble mango con forma ergonómica para una mayor comodidad, control y seguridad

## 3 Long fine neck for precise fingertip control

Langer Hals für präzise Führung mit der Fingerspitze  
Corps allongé et fin pour une meilleure maniabilité  
Cuello largo y fino para un control más preciso de los dedos

## 4 Ridges along the head give extra grip in that last 1/4 turn

Kanten entlang dem Kopf bieten zusätzliche Griffigkeit in der letzten 1/4-Umdrehung  
Les arêtes le long de la tête apportent le surplus de préhension nécessaire pour le dernier quart de tour  
Puntas con superficie estructurada que proporcionan un mayor agarre en el último 1/4 de apriete

## 5 Handle injection moulded directly to blade giving the ultimate bond for increased reliability & durability

Direkter Spritzguss des Handgriffs mit dem Schaft ergibt absolute Verbindung für erhöhte Zuverlässigkeit und Dauerhaftigkeit  
Manche moulé par injection directement sur la lame, gage de la meilleure des adhérences pour une fiabilité et une durabilité accrues  
Mango de inyección moldeado directamente en la varilla proporcionando el refuerzo fundamental para una mayor fiabilidad y durabilidad

## 6 GRIP-TIP™ anti cam-out ribs reduce the risk of slipping

GRIP-TIP™ Abgleitschutzrippen reduzieren das Risiko des Abrutschens  
Les nervures anti-rejet GRIP-TIP™ réduisent le risque de dérapage de l'outil  
GRIP-TIP™ bordes anticaída para reducir el riesgo de deslizamiento

## 7 Premium quality chrome vanadium steel blade for exceptional strength & durability

Hochqualitativer Chrom-Vanadiumstahlschaft für außergewöhnliche Festigkeit und Dauerhaftigkeit  
Lame en acier au chrome-vanadium de première qualité pour une résistance et une durabilité exceptionnelles  
Cuchilla de acero al cromo vanadio de alta calidad para una resistencia y durabilidad excepcionales

## 8 Precision machined tip for an exact screw fit & damage free screwdriving

Präzise bearbeitete Spitze für exakte Anpassungen an die Schrauben und beschädigungsfreies Eindrehen  
Pointe à usinage de précision pour un logement exact dans la tête de vis et un vissage sans dommages  
Punta mecanizada de precisión para el ajuste exacto del tornillo y sin causar daños al atornillar

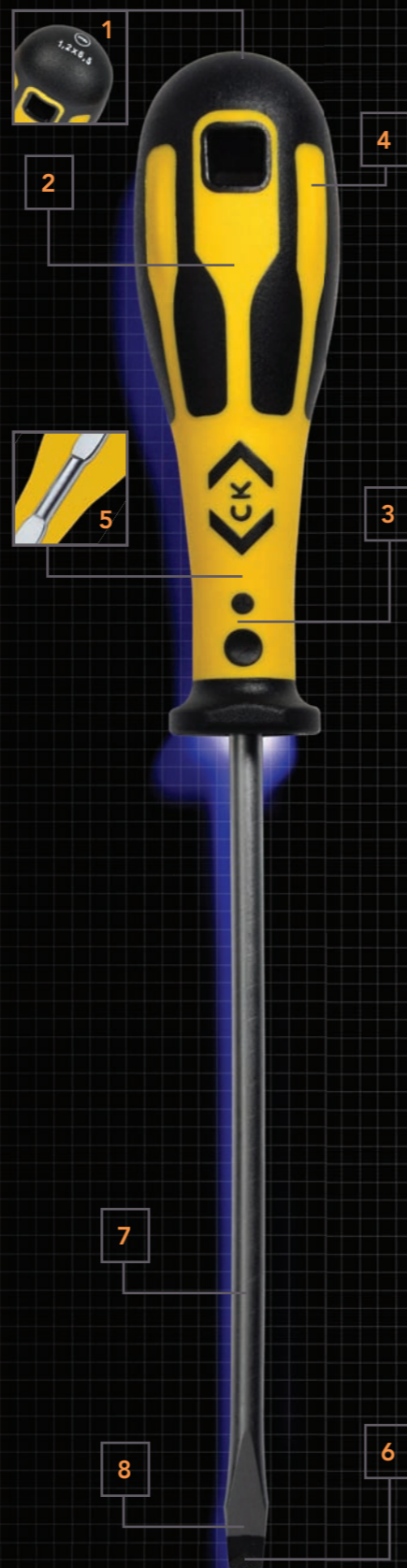

dextro™

featuring GRIP-TIP™ technology

## DEXTRO



### Screwdrivers - Slotted flared

ISO 2380, DIN 5264

Item Number	Tip	Length	Blade	Blade	Blade
T49110-040	4.0mm 5/32"	75mm 3"	0.8mm 0.031"	107mm 4 1/2"	6
T49110-055	5.5mm 7/32"	100mm 4"	1.0mm 0.039"	120mm 4 3/4"	6
T49110-065	6.5mm 1/4"	150mm 6"	1.2mm 0.047"	120mm 4 3/4"	6
T49110-100	10.0mm 25/64"	200mm 8"	1.6mm 0.063"	135mm 5 1/8"	6



### Screwdrivers - Slotted parallel

ISO 2380-2, DIN 5264

Item Number	Tip	Length	Blade	Blade	Blade
T49125-025	3.0mm 1/8"	75mm 3"	0.4mm 0.061"	95mm 3 3/4"	6
T49125-030	3.0mm 1/8"	75mm 3"	0.5mm 0.020"	95mm 3 3/4"	6
T49125-03025	3.0mm 1/8"	250mm 10"	0.5mm 0.020"	95mm 3 3/4"	6
T49125-035	3.5mm 9/64"	100mm 4"	0.6mm 0.024"	95mm 3 3/4"	6
T49125-040	4.0mm 5/32"	125mm 5"	0.8mm 0.031"	107mm 4 1/2"	6
T49125-055	5.5mm 7/32"	150mm 6"	1.0mm 0.039"	120mm 4 3/4"	6



### Screwdrivers - PH

ISO 8764

Item Number	Tip	Blade	Blade	Blade
T49113-0	PZ0	3.5mm 5/64"	60mm 2 3/8"	95mm 3 3/4"
T49113-1	PZ1	5.0mm 3/16"	75mm 3"	107mm 4 1/2"
T49113-1250	PZ1	5.0mm 3/16"	250mm 10"	107mm 4 1/2"
T49113-2	PZ2	6.0mm 5/16"	150mm 6"	120mm 4 3/4"
T49113-2250	PZ2	6.0mm 5/16"	250mm 10"	120mm 4 3/4"
T49113-3	PZ3	8.0mm 5/16"	150mm 6"	135mm 5 1/8"



### Screwdrivers - TX

ISO 8764

Item Number	Tip	Blade	Blade	Blade
T49112-0	PH0	3.5mm 5/64"	60mm 2 3/8"	95mm 3 3/4"
T49112-1	PH1	5.0mm 3/16"	80mm 3 1/8"	107mm 4 1/2"
T49112-1250	PH1	5.0mm 3/16"	250mm 10"	107mm 4 1/2"
T49112-2	PH2	6.0mm 5/16"	100mm 4"	120mm 4 3/4"
T49112-2250	PH2	6.0mm 5/16"	250mm 10"	120mm 4 3/4"
T49112-3	PH3	8.0mm 5/16"	150mm 6"	135mm 5 1/8"



### Screwdrivers - TX

Item Number	Tip	Blade	Blade	Blade
T49117-06	T 06	3.0mm 1/8"	70mm 2 3/4"	95mm 3 3/4"
T49117-07	T 07	3.0mm 1/8"	70mm 2 3/4"	95mm 3 3/4"
T49117-08	T 08	3.0mm 1/8"	70mm 2 3/4"	95mm 3 3/4"
T49117-09	T 09	3.0mm 1/8"	70mm 2 3/4"	95mm 3 3/4"
T49117-10	T 10	3.0mm 1/8"	80mm 3 1/8"	107mm 4 1/2"
T49117-15	T 15	3.5mm 9/64"	80mm 3 1/8"	107mm 4 1/2"
T49117-20	T 20	4.0mm 5/32"	90mm 3 1/2"	107mm 4 1/2"
T49117-25	T 25	4.5mm 11/64"	90mm 3 1/2"	107mm 4 1/2"
T49117-27	T 27	5.5mm 7/32"	110mm 4 1/4"	120mm 4 3/4"
T49117-30	T 30	6.0mm 5/16"	110mm 4 1/4"	120mm 4 3/4"
T49117-40	T 40	7.0mm 9/32"	120mm 4 3/4"	135mm 5 1/8"

CONTENTS: 1 x slotted flared, sizes: 4.0 x 75, 5.5 x 100 & 6.5 x 150mm. 1 x slotted parallel, size: 3.0 x 75mm. 1 x PZ, sizes: 0 x 60, 1 x 80 & 2 x 100mm.



**Screwdriver set -  
7 Piece SL/PZ**

DIN ISO 2380, DIN ISO 8764

Item Number	
T49163	1

CONTENTS: 1 x slotted flared, sizes: 4.0 x 75, 5.5 x 100 & 6.5 x 150mm. 1 x slotted parallel, size: 3.0 x 75mm. 1 x PH, sizes: 0 x 60, 1 x 80 & 2 x 100mm.



**Screwdriver set -  
7 Piece SL/PH**

DIN ISO 2380, DIN ISO 8764

Item Number	
T49162	1

CONTENTS: 1 x slotted flared, sizes: 4.0 x 75, 5.5 x 100 & 6.5 x 150mm. 1 x PZ, sizes: 1 x 80 & 2 x 100mm.



**Screwdriver set -  
5 Piece SL/PZ**

DIN ISO 2380, DIN ISO 8764

Item Number	
T49153	1

CONTENTS: 6 x slotted flared, sizes: 5.5 x 100, 6.5 x 150 & 10.0 x 200mm. 6 x slotted parallel, sizes: 3.0 x 75 & 4.0 x 125mm. 6 x PZ, sizes: 0 x 60, 1 x 80, 2 x 100 & 2 x 250mm. 6 x PH, sizes: 1 x 80 & 2 x 100mm.



**Top sellers display**

Item Number		
DEXTRO-TS	stock, shelf & header	1

- Optional countertop Z-frame available



**Countertop Z-frame**

Item Number	
M0162	1

CONTENTS: 6 x slotted flared, sizes: 4.0 x 75, 5.5 x 100, 6.5 x 150 & 10.0 x 200mm. 6 x slotted parallel, sizes: 2.5 x 75, 3.0 x 75, 3.0 x 250, 3.5 x 100, 4.0 x 125 & 5.5 x 150mm. 6 x PH, size: 0 x 60mm.



**Full range display -  
Shelf 1**

Item Number		
DEXTRO-S1	stock, shelf & header	1

CONTENTS: 6 x PZ, sizes: 0 x 60, 1 x 80, 1 x 250, 2 x 100, 2 x 250 & 3 x 150mm. 6 x PH, sizes: 1 x 80, 1 x 250, 2 x 100, 2 x 250 & 3 x 150mm.

**Shelf 2**

Item Number		
DEXTRO-S2	stock, shelf & header	1

CONTENTS: 6 x TX, sizes: 6 x 70, 7 x 70, 8 x 70, 9 x 70, 10 x 80, 15 x 80, 20 x 90, 25 x 90, 27 x 110, 30 x 110 & 40 x 120mm.

**Shelf 3**

Item Number		
DEXTRO-S3	stock, shelf & header	1

# HD CLASSIC

## CLASSIC HEAVY DUTY SCREWDRIVERS

KLASSISCHE SCHWERLASTSCHRAUBENDREHER  
TOURNEVIS HAUTES PERFORMANCES CLASSIQUES  
DESTORNILLADORES CLASSIC PARA TRABAJOS PESADOS



- 1 Shatter resistant acetate handle - wipe clean, oil & acid resistant**  
Splittersicherer Azetathandgriff - Reinigung durch Abwischen, öl- und säurefest  
Manche en acétate incassable - facile à nettoyer et résistant aux huiles et aux attaques acides  
Mango de acetato resistente a los choques, de fácil limpieza y resistentes al aceite y ácido
- 2 Large square shape handle design for maximum torque**  
Großer viereckiger Handgriff für maximales Drehmoment  
Manche de forme carrée de grandes dimensions pour un couple maximum  
Diseño de mango grande y cuadrado para conseguir una máxima torsión
- 3 Handle injection moulded directly to blade giving the ultimate bond for increased reliability & durability**  
Direkter Spritzguss des Handgriffs mit dem Schaft ergibt absolute Verbindung für erhöhte Zuverlässigkeit und Dauerhaftigkeit  
Manche moulé par injection directement sur la lame, gage de la meilleure des adhérences pour une fiabilité et une durabilité accrues  
Mango de inyección moldeado directamente en la varilla proporcionando el refuerzo fundamental para una mayor fiabilidad y durabilidad
- 4 Anti roll flats to prevent the screwdriver rolling off sloping surfaces**  
Flächen am Handgriff verhindern das Abrollen des Schraubendrehers von rutschigen Oberflächen  
Facettes anti-roulis pour empêcher le tournevis de rouler sur les plans inclinés  
Plataformas antideslizantes para evitar que el destornillador se desplace en superficies inclinadas
- 5 Chrome plated toughened alloy steel blade for increased strength & durability**  
Verchromter und verstärkter Schaft aus legiertem Stahl für erhöhte Festigkeit und Dauerhaftigkeit  
Lames en acier allié durci chromé pour une résistance et une durabilité accrues  
Varilla de aleación de acero endurecida, cromada para mayor resistencia y durabilidad
- 6 Precision machined tip for an exact screw fit & damage free screwdriving**  
Präzise bearbeitete Spitze für exakte Anpassungen an die Schrauben und beschädigungsfreies Eindrehen  
Pointe à usinage de précision pour un logement exact dans la tête de vis et un vissage sans dommages  
Punta mecanizada de precisión para el ajuste exacto del tornillo y sin causar daños al atornillar

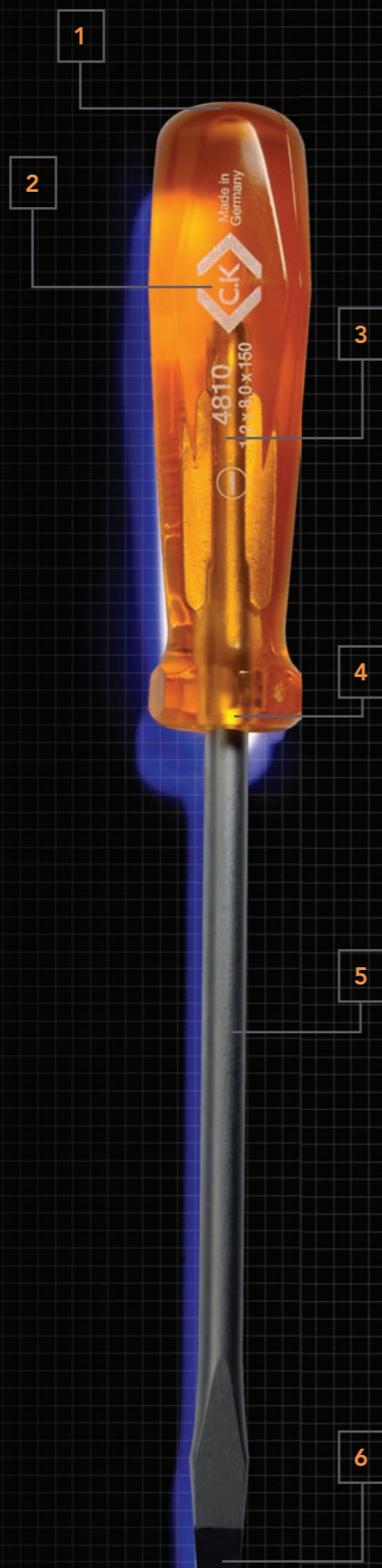

# HDclassic

## HD CLASSIC



### Screwdrivers - Slotted flared

DIN 5264, ISO 2380-2

Item Number	Blade Width	Blade Length	Blade Thickness	Blade Diameter	Blade Tip Length	Quantity
T4810 03	5mm 3/16"	75mm 3"	0.8mm 0.03"	90mm 3 1/2"	6	
T4810 04	6mm 1/8"	100mm 4"	1.0mm 0.04"	100mm 4"	6	
T4810 05	7mm 9/32"	125mm 5"	1.0mm 0.04"	100mm 4"	6	
T4810 06	8mm 5/16"	150mm 6"	1.2mm 0.05"	110mm 4 1/4"	6	
T4810 08	9mm 11/32"	200mm 8"	1.2mm 0.05"	120mm 4 3/4"	6	
T4810 10	10mm 3/8"	250mm 10"	1.6mm 0.06"	130mm 5 1/8"	6	
T4810 12	12mm 1/2"	300mm 12"	2.0mm 0.08"	130mm 5 1/8"	6	



### Screwdrivers - Slotted parallel

DIN 5264, ISO 2380-2

Item Number	Blade Width	Blade Length	Blade Thickness	Blade Diameter	Blade Tip Length	Quantity
T4965 03	3mm 1/8"	75mm 3"	0.5mm 0.02"	70mm 2 3/4"	6	
T4975 06	3mm 1/8"	150mm 6"	0.5mm 0.02"	80mm 3 1/8"	6	
T4975 08	3mm 1/8"	200mm 8"	0.5mm 0.02"	80mm 3 1/8"	6	
T4965 04	4mm 5/32"	100mm 4"	0.8mm 0.03"	80mm 3 1/8"	6	
T4975 10	4mm 5/32"	250mm 10"	0.8mm 0.03"	80mm 3 1/8"	6	
T4965 05	4.5mm 11/64"	125mm 5"	0.8mm 0.03"	80mm 3 1/8"	6	
T4965 06	5mm 3/16"	150mm 6"	0.8mm 0.03"	90mm 3 1/2"	6	
T4965 08	6mm 1/8"	300mm 12"	0.8mm 0.03"	90mm 3 1/2"	6	
T4965 12	6mm 1/8"	300mm 12"	0.8mm 0.03"	90mm 3 1/2"	6	



### Screwdrivers - PZ

ISO 8764

Item Number	Blade Width	Blade Length	Blade Thickness	Blade Diameter	Blade Tip Length	Quantity
T4813 0	PZ0 3.5mm 3/16"	60mm 2 1/2"	70mm 2 3/4"	6		
T4813 1	PZ1 5mm 3/16"	80mm 3 1/8"	90mm 3 1/2"	6		
T4813 2	PZ2 6mm 1/8"	100mm 4"	100mm 4"	6		
T4987 1	PZ1 5mm 3/16"	250mm 10"	100mm 4"	6		
T4813 2	PZ2 6mm 1/8"	100mm 4"	100mm 4"	6		
T4987 2	PZ2 6mm 1/8"	250mm 10"	110mm 4 1/4"	6		
T4813 3	PZ3 8mm 5/16"	150mm 6"	110mm 4 1/4"	6		
T4813 4	PZ4 10mm 3/8"	200mm 8"	120mm 4 3/4"	6		

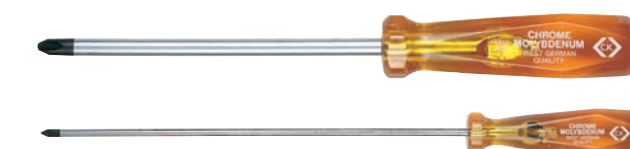

### Screwdrivers - PH

ISO 8764

Item Number	Blade Width	Blade Length	Blade Thickness	Blade Diameter	Blade Tip Length	Quantity
T4812 0	PH0 3.5mm 3/16"	65mm 2 1/2"	70mm 2 3/4"	6		
T4812 1	PH1 5mm 3/16"	80mm 3 1/8"	90mm 3 1/2"	6		
T4977 1	PH1 5mm 3/16"	250mm 10"	100mm 4"	6		
T4812 2	PH2 6mm 1/8"	100mm 4"	100mm 4"	6		
T4977 2	PH2 6mm 1/8"	250mm 10"	110mm 4 1/4"	6		
T4812 3	PH3 8mm 5/16"	150mm 6"	110mm 4 1/4"	6		
T4812 4	PH4 10mm 3/8"	200mm 8"	120mm 4 3/4"	6		



### Screwdrivers - Stubby slotted

DIN 5264, ISO 2380-2

Item Number	Blade Width	Blade Length	Blade Thickness	Blade Diameter	Blade Tip Length	Quantity
T4814 25	6.5mm 1/4"	25mm 1"	1.2mm 0.05"	60mm 2 3/8"	6	
T4814 31	8mm 5/16"	25mm 1"	1.2mm 0.05"	60mm 2 3/8"	6	



### Screwdrivers - Stubby PZ

ISO 8764

Item Number	+	Ø	↔	↔	📦
T4816 1	PZ1	5mm 3/16"	25mm 1"	60mm 2 3/8"	6
T4816 2	PZ2	6mm 1/4"	25mm 1"	60mm 2 3/8"	6



### Screwdrivers - Stubby PH

ISO 8764

Item Number	+	Ø	↔	↔	📦
T4815 1	PH 1	5mm 3/16"	25mm 1"	60mm 2 3/8"	6
T4815 2	PH 2	6mm 1/4"	25mm 1"	60mm 2 3/8"	6



### Screwdrivers - Slotted strike through

Item Number	+	↔	↔	↔	📦
T4811 04	6mm 1/4"	100mm 4"	1.0mm 0.04"	100mm 4"	6
T4811 06	8mm 5/16"	150mm 6"	1.2mm 0.05"	110mm 4 1/4"	6
T4811 08	10mm 3/8"	200mm 8"	1.6mm 0.06"	120mm 4 3/4"	6
T4811 10	13mm 1/2"	250mm 10"	2.0mm 0.08"	130mm 5 1/8"	6



### Nut spinners

DIN 3125

Item Number	Ø	↔	↔	📦
T4334M 03	3mm	130mm 5 1/8"	90mm 3 1/2"	3
T4334M 035	3.5mm	130mm 5 1/8"	90mm 3 1/2"	3
T4334M 04	4mm	130mm 5 1/8"	90mm 3 1/2"	3
T4334M 045	4.5mm	130mm 5 1/8"	90mm 3 1/2"	3
T4334M 05	5mm	130mm 5 1/8"	90mm 3 1/2"	3
T4334M 055	5.5mm	130mm 5 1/8"	90mm 3 1/2"	3
T4334M 06	6mm	130mm 5 1/8"	90mm 3 1/2"	3
T4334M 07	7mm	130mm 5 1/8"	100mm 4"	3
T4334M 08	8mm	130mm 5 1/8"	100mm 4"	3
T4334M 09	9mm	130mm 5 1/8"	100mm 4"	3
T4334M 10	10mm	130mm 5 1/8"	100mm 4"	3
T4334M 11	11mm	120mm 4 3/4"	110mm 4 1/4"	3
T4334M 12	12mm	120mm 4 3/4"	110mm 4 1/4"	3
T4334M 13	13mm	120mm 4 3/4"	110mm 4 1/4"	3

CONTENTS: 1 x slotted flared, sizes: 6.0 x 100, 6.5 x 25, 7.0 x 125 & 8.0 x 100mm. 1 x slotted parallel, sizes: 3.0 x 75 & 4.0 x 100mm. 1 x PZ, sizes: 1 x 80 & 2 x 100mm.



### Screwdriver Set - 8 Piece SL/PZ

Item Number	📦
T4999B	1

CONTENTS: 6 x slotted flared, sizes: 6.5 x 25, 6.0 x 100 & 8.0 x 150mm. 6 x slotted parallel, sizes: 3.0 x 75 & 4.0 x 100mm. 6 x PZ, sizes: 0 x 60, 1 x 80, 2 x 25 & 2 x 100mm. 6 x PH, sizes: 1 x 80 & 2 x 100mm.



### Top sellers display

Item Number	i	📦
HDCLASSIC-TS	stock, shelf & header	1

- Optional countertop Z-frame available



### Countertop Z-frame

Item Number	📦
M0162	1

CONTENTS: 6 x slotted parallel, sizes: 3.0 x 150, 3.0 x 200, 4.0 x 250 & 6.0 x 300mm. 6 x slotted flared, sizes: 5.0 x 75, 6.0 x 100, 7.0 x 125, 8.0 x 150, 9.0 x 200, 10.0 x 250 & 12.0 x 300mm.



### Full range display - Shelf 1

Item Number	i	📦
HDCLASSIC-S1	stock, shelf & header	1

CONTENTS: 12 x slotted parallel, sizes: 3.0 x 75 & 4.0 x 100mm. 6 x slotted parallel, sizes: 4.5 x 125, 5.0 x 150 & 5.0 x 200mm. 6 x slotted strike-through, sizes: 6.0 x 100, 8.0 x 150, 10.0 x 200 & 13.0 x 250mm.

### Shelf 2

Item Number	i	📦
HDCLASSIC-S2	stock, shelf & header	1

CONTENTS: 12 x PZ, size: 2 x 100mm. 6 x PZ, sizes: 0 x 60, 1 x 80, 2 x 100, 3 x 150 & 4 x 200mm. 6 x PH, sizes: 0 x 65, 1 x 80, 2 x 100, 3 x 150 & 4 x 200mm.

### Shelf 3

Item Number	i	📦
HDCLASSIC-S3	stock, shelf & header	1

CONTENTS: 12 x slotted flared, sizes: 6.5 x 25mm. 6 x slotted flared, sizes: 8.0 x 25mm. 6 x PZ, sizes: 1 x 25, 2 x 25, 1 x 250 & 2 x 250mm. 6 x PH, sizes: 1 x 25, 2 x 25, 1 x 250 & 2 x 250mm.

### Shelf 4

Item Number	i	📦
HDCLASSIC-S4	stock, shelf & header	1

# TRITON XLS

## PROFESSIONAL GENERAL PURPOSE SCREWDRIVERS

PROFESSIONELLE MEHRZWECKSCHRAUBENDREHER

TOURNEVIS PROFESSIONNELS A USAGE UNIVERSEL

DESTORNILLADORES DE USO GENERAL PARA PROFESIONALES



### 1 Tip type marking for easy identification

Kopf Markierung zur einfachen Erkennung  
 Marquage du type de pointe pour une identification aisée  
 Tope superior marcado con el tipo de punta para facilitar su identificación

### 2 Large soft grip tri-lobe handle for exceptional comfort & high torque turns

Großer dreiflügeliger Handgriff mit weichem Griff für außergewöhnlichen Komfort und hohes Drehmoment  
 Grand manche à trois lobes à revêtement souple pour un confort exceptionnel et des couples de vissage élevés  
 Mango grande de agarre suave con tres salientes para un confort excepcional y alta torsión de apriete

### 3 Handle injection moulded directly to blade giving the ultimate bond for increased reliability & durability

Direkter Spritzguss des Handgriffs mit dem Schaft ergibt absolute Verbindung für erhöhte Zuverlässigkeit und Dauerhaftigkeit  
 Manche moulé par injection directement sur la lame, gage de la meilleure des adhérences pour une fiabilité et une durabilité accrues  
 Mango de inyección moldeado directamente en la varilla proporcionando el refuerzo fundamental para una mayor fiabilidad y durabilidad

### 4 Anti roll flats to prevent the screwdriver rolling off sloping surfaces

Flächen am Handgriff verhindern das Abrollen des Schraubendrehers von rutschigen Oberflächen  
 Facettes anti-roulis pour empêcher le tournevis de rouler sur les plans inclinés  
 Plataformas antideslizantes para evitar que el destornillador se desplace en superficies inclinadas

### 5 Chrome plated, toughened alloy steel blade for increased strength & durability

Verchromter und verstärkter Schaft aus legiertem Stahl für erhöhte Festigkeit und Dauerhaftigkeit  
 Lames en acier allié durci chromé pour une résistance et une durabilité accrues  
 Varilla de aleación acero endurecida, cromada para mayor resistencia y durabilidad

### 6 Magnetic tip holds the screw securely to the tip to aid positioning & setting

Magnetische Bit-Halterung hält die Schraube sicher an der Spitze und hilft bei der Positionierung und dem Ansetzen der Schraube  
 La pointe magnétisée retient solidement la vis au bout de l'outil et facilite l'approche et la pose  
 Punta magnética que mantiene el tornillo de forma segura en la punta para ayudar a su colocación y ajuste



## TRITON XLS



### Screwdrivers - Slotted flared

DIN ISO 2380

Item Number	Blade Width	Blade Length	Blade Thickness	Blade Diameter	Blade Material
T4720-055	5.5mm 7/32"	100mm 4"	1.0mm 0.039"	100mm 4"	6
T4720-065	6.5mm 1/4"	150mm 6"	1.2mm 0.047"	108mm 4 1/4"	6
T4720-100	10mm 3/8"	200mm 8"	1.6mm 0.063"	118mm 4 5/8"	6



### Screwdrivers - Slotted parallel

DIN ISO 2380

Item Number	Blade Width	Blade Length	Blade Thickness	Blade Diameter	Blade Material
T4725-030	3.0mm 1/8"	75mm 3"	0.6mm 0.024"	89mm 3 5/8"	6
T4725-040	4.0mm 5/32"	100mm 4"	0.8mm 0.031"	100mm 4"	6
T4725-055	5.5mm 7/32"	250mm 10"	1.0mm 0.039"	100mm 4"	6

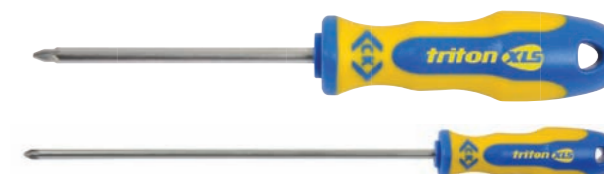

### Screwdrivers - PZ

DIN ISO 8764

Item Number	Blade Width	Blade Length	Blade Thickness	Blade Diameter	Blade Material
T4723-0	PZ0 3.0mm 1/8"	60mm 2 3/8"	89mm 3 5/8"	6	
T4723-1	PZ1 5.0mm 3/16"	75mm 3"	100mm 4"	6	
T4723-1250	PZ1 5.0mm 3/16"	250mm 10"	100mm 4"	6	
T4723-2	PZ2 6.0mm 5/16"	100mm 4"	108mm 4 1/4"	6	
T4723-2250	PZ2 6.0mm 5/16"	250mm 10"	108mm 4 1/4"	6	
T4723-3	PZ3 8.0mm 5/8"	150mm 6"	118mm 4 5/8"	6	



### Screwdrivers - PH

DIN ISO 8764

Item Number	Blade Width	Blade Length	Blade Thickness	Blade Diameter	Blade Material
T4722-0	PH0 3.0mm 1/8"	60mm 2 3/8"	89mm 3 5/8"	6	
T4722-1	PH1 5.0mm 3/16"	75mm 3"	100mm 4"	6	
T4722-1250	PH1 5.0mm 3/16"	250mm 10"	100mm 4"	6	
T4722-2	PH2 6.0mm 5/16"	100mm 4"	108mm 4 1/4"	6	
T4722-2250	PH2 6.0mm 5/16"	250mm 10"	108mm 4 1/4"	6	
T4722-3	PH3 8.0mm 5/8"	150mm 6"	118mm 4 5/8"	6	



CONTENTS: 1 x slotted flared, sizes: 5.5 x 100 & 6.5 x 150mm.  
1 x slotted parallel, size: 4.0 x 100mm. 1 x PZ, sizes: 1 x 75 & 2 x 100mm.



**Screwdriver set -  
5 Piece SL/PZ**

DIN ISO 2380, DIN ISO 8764

Item Number	
T4727	1

CONTENTS: 1 x slotted flared, sizes: 5.5 x 100 & 6.5 x 150mm.  
1 x slotted parallel, size: 4.0 x 100mm. 1 x PH, sizes: 1 x 75 & 2 x 100mm.



**Screwdriver set -  
5 Piece SL/PH**

DIN ISO 2380, DIN ISO 8764

Item Number	
T4726	1

CONTENTS: 1 x slotted parallel, sizes: 2.5 x 75, 4.0 x 100 & 5.5 x 125mm. 1 x PZ, sizes: 1 x 80 & 2 x 100mm.



**Screwdriver set -  
Insulated 5 Piece SL/PZ**

DIN ISO 2380, DIN ISO 8764, IEC 60900:2004

Item Number	
T4729	1

CONTENTS: 1 x slotted parallel, sizes: 2.5 x 75, 4.0 x 100 & 5.5 x 125mm. 1 x PH, sizes: 1 x 80 & 2 x 100mm.



**Screwdriver set -  
Insulated 5 Piece SL/PH**

DIN ISO 2380, DIN ISO 8764, IEC 60900:2004

Item Number	
T4728	1

CONTENTS: 6 x slotted flared, sizes: 5.5 x 100, 6.5 x 150 & 10.0 x 200mm. 6 x slotted parallel, sizes: 3.0 x 75 & 4.0 x 100mm. 6 x PZ, sizes: 0 x 60, 1 x 75, 2 x 100 & 2 x 250mm. 6 x PH, sizes: 1 x 75 & 2 x 100mm.



**Top sellers display**

Item Number		
TRITONXLS-TS	stock, shelf & header	1

- Optional countertop Z-frame available



**Countertop Z-frame**

Item Number	
M0162	1

CONTENTS: 6 x slotted flared, sizes: 5.5 x 100, 6 x 200 & 6.5 x 150mm. 12 x slotted parallel, size: 4.0 x 100mm. 6 x slotted parallel, sizes: 3.0 x 75 & 5.5 x 250mm. 6 x PZ, sizes: 1 x 250 & 2 x 250mm. 6 x PH, sizes: 1 x 250 & 2 x 250mm.



**Full range display -  
Shelf 1**

Item Number		
TRITONXLS-S1	stock, shelf & header	1

CONTENTS: 12 x PZ, sizes: 1 x 75 & 2 x 100mm. 6 x PZ, sizes: 0 x 60 & 3 x 150mm. 12 x PH, size: 2 x 100mm. 6 x PH, sizes: 0 x 60, 1 x 75 & 3 x 150mm.

**Shelf 2**

Item Number		
TRITONXLS-S2	stock, shelf & header	1

## MAINSTESTERS

- Premium quality VDE approved for assured safety
- Neon light for high visibility
- Finger slip guard for added safety
- Integrated pocket clip



**VDE Mainstester - 125-250V AC**

VDE0680 P6E

Item Number	Length	Tip	Quantity
440008	150mm	3mm	12
440009	190mm	3.5mm	12

- VDE approved mainstester for assured safety
- Neon light for high visibility



**VDE Mainstester - 220-250V AC**

VDE0680 P6E

Item Number	Length	Tip	Tip	Quantity
440012	100mm	4mm	0.6mm	12

- VDE approved mainstester for assured safety
- Neon light for high visibility
- Pocket clip



**VDE Mainstester with pocket clip - 220-250V AC**

VDE0680 P6E

Item Number	Length	Tip	Tip	Quantity
440007	65mm	3mm	0.5mm	12

- Extended shaft for long reach applications
- Insulated for protection
- Neon light for high visibility



**Mainstester - 100-250V AC**

Item Number	Length	Tip	Tip	Quantity
440013	120mm	4mm	0.6mm	12



**Mainstester display box - 20 Piece 100-250V AC**

Item Number	Description	Quantity
540014	box of 440013	1

## RATCHET SCREWDRIVERS

- Hi-torque ratchet mechanism for durability
- Left & right hand rotation plus lock action for convenience
- Magnetic shaft for secure bit retention
- Cushion grip handle with convenient internal bits storage compartment

CONTENTS: Ratchet driver. 1/4" square drive adapter. Screwdriver bits: 1 x slotted, sizes: 3.0, 4.0, 4.5, 5.0, 6.0, 7.0, 8.0 & 9.0mm. 1 x PH, sizes: 0, 1, 2 & 3. 1 x PZ, sizes: 0, 1, 2 & 3. 1 x hexagon, sizes: 1.5, 2.0, 2.5, 3.0, 4.0, 5.0, 5.5 & 6.0mm. 1 x TX tamperproof, sizes: 8, 10, 15, 20, 25, 27, 30 & 40. Sockets: 1 x metric, sizes: 6, 7, 8, 10, 11 & 13mm. 1 x imperial, sizes: 3/16, 1/4, 5/16, 11/32, 3/8 & 7/16".



**Ratchet screwdriver bit & socket set**

Item Number	Description	Quantity
T4826D	46 piece set	3

- Hi-torque ratchet mechanism for durability
- Left & right hand rotation plus lock action for convenience
- Magnetic shaft for secure bit retention
- Cushion grip handle with convenient internal bits storage compartment

CONTENTS: Ratchet screwdriver. Screwdriver bits: 1 x slotted, sizes: 3.0, 4.7 & 6.3mm. 1 x PH, size: 2. 1 x PZ, sizes: 1, 2 & 3. 1 x hexagon, sizes: 3, 4 & 5mm.



**Ratchet screwdriver & bits set**

Item Number	Description	Quantity
T4829D	11 piece set	3

## IMPACT DRIVER & BITS

- Heavy duty steel body - strong and durable
- Chrome plated for corrosion protection
- Shock absorbing grip for comfort & protection
- Twist to reverse function for convenience
- High strength chrome vanadium bits
- Steel case for convenient storage

CONTENTS: Impact driver. 1/2" to 1/4" drive adapter. Screwdriver bits: 1 x slotted, sizes: 8 & 10mm. 1 x PH, sizes: 2 & 3.



**Impact driver set**

Item Number	Description	Quantity
T4928	6 piece set	2

## Impact driver bits

Item Number	Tip	Length	Quantity
T4928 362	+	PH2 x 36mm	10
T4928 363	+	PH3 x 36mm	10
T4928 36M08	●	8 x 36mm	10
T4928 36M10	●	10 x 36mm	10
T4928 36M12	●	12 x 36mm	10
T4928 36P2	*	PZ2 x 36mm	10
T4928 36P3	*	PZ3 x 36mm	10
T4928 802	+	PH2 x 80mm	10
T4928 803	+	PH3 x 80mm	10

## BRADAWLS

- Nickel plated hardened steel blade for a long life
- Shatterproof ball ended acetate handle for comfort and safety



**Bradawl - Round**

Item Number	Tip	Length	Length	Quantity	
T4835	6mm	7/32"	100mm 4"	85mm 3/4"	6



**Bradawl - Square**

Item Number	Tip	Length	Length	Quantity	
T4831 2	100mm	4"	85mm	3/4"	6



**Bradawl display box - 50 Square assorted length**

Item Number	Description	Quantity
T4831	50 in counter box	1



**TOOL KITS**

WERKZEUGSÄTZE  
TROUSSES ET SACOCHES D'OUTILLAGE  
CONJUNTOS DE HERRAMIENTAS

**50-51****JOKARI CABLE KNIVES**

JOKARI-KABELMESSER  
COUTEAUX À DÉNUDER JOKARI  
JOKARI CUCHILLOS PARA CABLES

**52-53****JOKARI CABLE STRIPPERS**

JOKARI-KABELABISOLIERER  
OUTILS À DÉNUDER JOKARI  
ALICATES PELACABLES JOKARI

**53****JOKARI AUTO CABLE/WIRE STRIPPERS**

AUTOM. JOKARI-KABEL-/  
DRAHTABISOLIERER  
OUTILS À DÉNUDER AUTOMATIQUES  
POUR CÂBLES ET FILS JOKARI  
JOKARI ALICATES PELACABLES/  
PELAALAMBRES AUTOMÁTICOS

**54****CABLE AND WIRE STRIPPING TOOLS**

KABEL- UND  
DRAHTABISOLIERUNGSWERKZEUGE  
OUTILS DE DÉNUDAGE DES CÂBLES  
ET FILS  
HERRAMIENTAS PARA PELAR CABLES  
Y ALAMBRES

**55****CABLE CUTTING**

KABEL SCHNEIDEN  
COUPE CÂBLES  
CORTAR CABLE

**55-56****CABLE TIE GUNS**

KABELBINDERPISTOLE  
PISTOLETS POUR LIGATEUR DE CÂBLES  
PISTOLAS DE BRIDAS

**56****DRAW TAPES**

EINZIEHBÄNDER  
TIR-FILS  
FLEJES (CINTA DE ACERO)

**56****SWITCH KEYS**

SCHALTSCHRANKSCHLÜSSEL  
CLÉS UNIVERSELLES  
LLAVES EN CRUZ (MULTIFUNCIÓN)

**57****SOLDERING IRONS**

LÖTKOLBEN  
FERS À SOUDER  
SOLDADORES

**57****PUNCH DOWN TOOL**

AUFLEGEWERKZEUG  
OUTIL D'ENFICHAGE  
HERRAMIENTA DE PERFORACIÓN

**57****RE-THREADING TOOL**

GEWINDENACHSCHNEIDWERKZEUGE  
OUTILS À REFILETER  
HERRAMIENTAS DE ROSCADO

**57**

# ELECTRICIAN'S TOOLS

ELEKTRIKERWERKZEUGE  
AUTRES OUTILS D'ELECTRICIEN  
HERRAMIENTAS DE ELECTRICISTA



**TOOL KITS**

CONTENTS: Technician's tool case. Redline VDE Combicutter3™ 165mm. Combination pliers 185mm. Snipe nose pliers 175mm. 1 x Dextro VDE screwdrivers, slotted, sizes: 2.5 x 75 & 4 x 100mm; PZ, sizes: 1 x 80 & 2 x 100mm; PH, sizes: 1 x 80 & 2 x 100mm; Modulo, size: 2. VDE mainstester. ST tape 5m/16ft. Junior hacksaw. Electrician's knife. Automatic wire strippers. Pocket level. Re-threading tool M3.5. Claw hammer.



**Electrician's premium tool kit - UK**

Item Number	i	
595003	19 piece kit	1

CONTENTS: Tool wallet. Redline VDE combicutter1™ 160mm. Wire stripping pliers 200mm. Snipe nose pliers 170mm. 1 x Dextro VDE screwdriver, slotted, sizes: 2.5 x 75, 3.0 x 100 & 5.5 x 125mm; PZ, sizes: 1 x 80 & 2 x 100mm. VDE mainstester.



**VDE Pliers & screwdrivers kit - PZ UK**

Item Number	i	
331001	10 piece kit	1

CONTENTS: Technician's tool case. Redline VDE side cutters 165mm. Combination pliers 175mm. Snipe nose pliers 175mm. 1 x Dextro VDE screwdriver, slotted, sizes: 2.5 x 75 & 4 x 100mm; PZ, sizes: 1 x 80 & 2 x 100mm; PH, sizes: 1 x 80 & 2 x 100mm; Modulo, sizes: 1 & 2. VDE mainstester. ST tape 8m. Mini hacksaw. Electrician's knife. Automatic wire strippers. Cable knife. Plasterboard saw.



**Electrician's premium tool kit - European**

Item Number	i	
T1630 FKIT	17 piece kit	1

CONTENTS: Tool wallet. Redline VDE combicutter1™ 160mm. Wire stripping pliers 200mm. Snipe nose pliers 170mm. 1 x Dextro VDE screwdriver, slotted, sizes: 2.5 x 75, 3.0 x 100 & 5.5 x 125mm; PH, sizes: 1 x 80 & 2 x 100mm. VDE mainstester.



**VDE Pliers & screwdrivers kit - PH UK**

Item Number	i	
331002	10 piece kit	1

CONTENTS: Electrician's tool belt set. Redline VDE combicutter3™ side cutters 165mm. Combination pliers 185mm. Snipe nose pliers 175mm. 1 x Dextro VDE screwdriver, slotted, sizes: 2.5 x 75, 5.5 x 125 & 6.5 x 150mm; PZ, size: 2 x 100; Modulo, size: 2. VDE mainstester. ST tape 5m/16ft. Junior hacksaw. Electrician's knife. Pocket level.



**Electrician's toolbelt kit**

Item Number	i	
595001	14 piece kit	1

CONTENTS: Tool wallet. Redline VDE side cutters 160mm. Wire stripping pliers 200mm. Snipe nose pliers 170mm. 1 x Dextro VDE screwdriver, slotted, sizes: 2.5 x 75, 3.0 x 100 & 5.5 x 125mm; PZ, sizes: 1 x 80 & 2 x 100mm. VDE mainstester.



**VDE Pliers & screwdrivers kit - PZ European**

Item Number	i	
331003	10 piece kit	1

CONTENTS: Tool wallet. RedLine VDE combicutter3™ 160mm. 1 x Dextro screwdriver, slotted, sizes: 3 x 100 & 4 x 100mm; PZ, size: 2. VDE mainstester. ST tape measure 5m/16ft. Electrician's scissors. Pocket level. Re-threading tool M3.5.



**Electrician's core tool kit**

Item Number	i	
595002	10 piece kit	1

CONTENTS: Tool wallet. Redline VDE side cutters 160mm. Wire stripping pliers 200mm. Snipe nose pliers 170mm. 1 x Dextro VDE screwdriver, slotted, sizes: 2.5 x 75, 3.0 x 100 & 5.5 x 125mm; PH, sizes: 1 x 80 & 2 x 100mm. VDE mainstester.



**VDE Pliers & screwdrivers kit - PH European**

Item Number	i	
331004	10 piece kit	1

**JOKARI**  
original

## PRECISION CABLE & WIRE STRIPPING TOOLS

Top quality products manufactured in Germany to the highest standards, Jokari products offer quick and easy cable & wire stripping without the risk of damage.

### CABLE KNIVES



### CABLE STRIPPERS



### AUTO CABLE/WIRE STRIPPERS



## JOKARI CABLE KNIVES

- Cutting blade automatically repositions from cutting around, to cutting along the sheath for fast and damage free stripping
- Adjustable cutting depth to prevent damage to the conductors
- High grade wear resistant polyamide construction - light and strong
- Spare cutting blade in the handle



### Jokari cable knife

Item Number	Ø	📦
T10160	4 - 16mm $\frac{5}{32}$ - $\frac{5}{16}$ "	6
T10270	8 - 28mm $\frac{5}{16}$ - $1\frac{1}{8}$ "	6

- Fully insulated for safe working



### Jokari cable knife - Insulated

Item Number	Ø	📦
T10271	8 - 28mm $\frac{5}{16}$ - $1\frac{1}{8}$ "	6

- Additional external hook & straight blade for convenience



### Jokari cable knife with blade

Item Number	Ø	📦
T10280	8 - 28mm $\frac{5}{16}$ - $1\frac{1}{8}$ "	6

- Additional external hook & straight blade for convenience

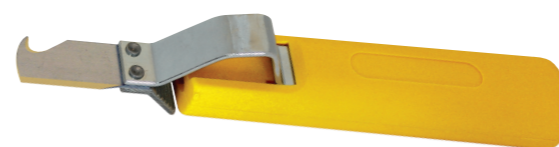

### Jokari economy cable knife with blade

Item Number	Ø	📦
T10283	8 - 28mm $\frac{5}{16}$ - $1\frac{1}{8}$ "	6

- Spare cutting blades for all Jokari cable knives

### Jokari spare cutting blades

Item Number	i	📦
T19000	3 piece set	10

## JOKARI CABLE STRIPPERS

- Razor sharp, preset stripping blades for fast, precise and damage free stripping of all common flat and oval cables
- Pre-set precision stripping blades for damage free wire stripping



### Jokari cable stripper - Flat

Item Number	mm <sup>2</sup> / AWG	Ø	📦
T30140	Wire stripping 0.8, 1.5, 2.5 / 20, 16, 14	Cable stripping 12mm $\frac{1}{2}$ "	6

- Razor sharp, preset stripping blades for fast, precise and damage free stripping of all common round cables



### Jokari cable stripper - Round

Item Number	Ø	📦
T30120	Cable stripping 8 - 13mm $\frac{5}{16}$ - $\frac{1}{2}$ "	6

- Razor sharp, preset stripping blades for fast, precise and damage free stripping of round cables
- Pre-set precision stripping blades for damage free wire stripping
- Retractable trimming knife blade for convenience
- Titanium-Nitride coated blades for increased durability



### Jokari stripper - Round

Item Number	mm <sup>2</sup> / AWG	Ø	📦
T30155	Wire stripping 0.2, 0.3, 0.8, 1.5, 2.5, 4.0 / 24, 22, 20, 16, 14, 12	Cable stripping 8 - 13mm $\frac{5}{16}$ - $\frac{1}{2}$ "	6

- Razor sharp, preset stripping blades for fast, precise and damage free stripping of datacomms cables
- Pre-set precision stripping blades for damage free wire stripping



### Jokari cable stripper - Datacoms

Item Number	mm <sup>2</sup> / AWG	Ø	📦
T30160	Wire stripping 0.2, 0.3, 0.8, 1.5, 2.5, 4.0 / 24, 22, 20, 16, 14, 12	Cable stripping 5 - 15mm $\frac{3}{16}$ - $\frac{5}{16}$ "	6

- Razor sharp, preset stripping blades for fast, precise and damage free stripping of all common coaxial cables
- Also suitable for stripping 3-core flex



### Jokari cable stripper - Coaxial

Item Number	mm <sup>2</sup> / AWG	📦
T30010	4.8 & 7.5mm / $\frac{3}{16}$ & $\frac{5}{32}$ "	6

## JOKARI AUTO CABLE/WIRE STRIPPERS

- Fibreglass-reinforced polyamide construction for high strength and light weight
- Ergonomically designed for fatigue free, repetitive stripping
- Stripping length scale for consistent results

- Designed for solid & stranded wires
- Automatic wire size adjustment for convenience
- Integrated wire cutter



Jokari auto wire stripper - Single core

Item Number	mm <sup>2</sup> / AWG	
T20050	0.2 - 6.0 / 24 - 10	6

- Designed for stripping difficult insulations, e.g. PMMA fibre optic cables with PE sheath, PVC, rubber, silicon and TPE



Jokari auto wire stripper - Tough insulation

Item Number	mm <sup>2</sup> / AWG	
T20450	0.5 - 4.0 / 20 - 11	6

- Designed for flat twin and earth cables
- Automatic cable size adjustment for convenience



Jokari auto cable stripper - Flat

Item Number	mm <sup>2</sup> / AWG	
T20030	0.75 - 2.5 / 18 - 14	6

- Designed for larger diameter wire and 3-core PVC flex
- Automatic cable size adjustment for convenience



Jokari auto cable stripper - Round

Item Number	mm <sup>2</sup> / AWG	
T20090	6 - 16 / 10 - 5	6

- Designed for solid & stranded wires
- Automatic wire size adjustment for convenience



Jokari auto wire stripper - Side cutter

Item Number	mm <sup>2</sup> / AWG	
T20060	0.5 - 6.0 / 20 - 10	6

## CABLE & WIRE STRIPPING TOOLS

- Designed for fatigue free, repetitive stripping of flat & round cable & wire
- Automatic wire size adjustment and stripping length stop for consistent results
- Integrated wire cutter and crimping jaws for convenience



Automatic wire stripper

Item Number	i	
495001	Stripping - 0.2 - 6.0mm; Cutting - HRC 40 - 50; Crimping - 0.5 - 6.0mm terminals.	3

- Dual purpose cable stripper and plastic tube cutting tool
- Cutting blade automatically repositions from cutting around, to cutting along the sheath for fast and damage free stripping
- Adjustable cutting depth for damage free stripping

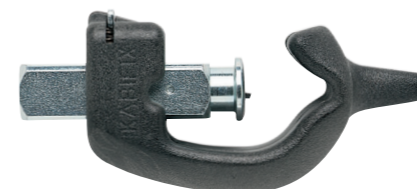

Cable stripper - Kabifix

Item Number	∅	
430004	6 - 28mm	3

Cable stripper - Kabifix spare blade

Item Number	
395041	10

- Locking pocket knife with a durable, sharp, high carbon steel blade and wire stripping notch for fast and convenient cable & wire stripping



Electrician's knife

Item Number		
484001	95mm 3 7/8"	3

- Specially adapted knife for slitting the outer sheath of cables without damaging inner wire insulation
- Individually tested to 10,000V for safe live working up to 1,000V



VDE Cable sheath slitting knife

ASTM-F 1505, EN 60900, VDE0682/201

Item Number		
484005	185mm 3 1/2"	3

## CABLE CUTTING

- Heavy duty, ratchet action cutters for effortlessly cutting of large diameter cable
- Hardened chrome molybdenum steel blade specially designed for cutting hard drawn copper, aluminium cable or 200 pair communications cable (Not for use on steel armoured cable)



Cable cutter - Ratchet

Item Number		∅	
430007	190mm	32mm	3

Cable cutter - Ratchet Spare blade

Item Number	i	
Z3677 1	moving	3
Z3677 2	fixed	3

- Special alloy steel construction with razor sharp, induction hardened cutting edges for outstanding cutting performance
- Suitable for copper & aluminium wire only

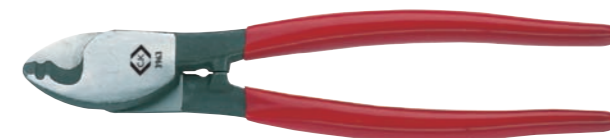

Cable cutters

Item Number		∅	
T3963	210mm 8"	11mm	3
T3963 240	240mm 9 1/2"	13mm	3

- Designed for fast and efficient cutting of aluminium & copper wires and plastic sheathed cables
- Stainless steel razor sharp shearing blades for outstanding cutting performance
- Spring assisted blade opening with safety closing catch for convenience
- PVC coated handles for comfort and grip



**Cable snips**

Item Number	Length	Quantity
430008	165mm 6 1/2"	3

- Heavy duty design for shearing soft cables, insulation materials, tape, cable ties and many other materials
- Micro serrated stainless steel blades, hollow ground for self sharpening, superior cutting performance
- Integrated cutting notch for effective cable & wire stripping
- Belt pouch for convenient storage



**Electrician's scissors**

Item Number	Length	Quantity
492001	140mm 10"	6

**CABLE TIE GUNS**

- Designed for automatic tensioning and trimming of cable ties
- Heavy duty stainless steel construction for outstanding long term performance
- Tension adjuster for the perfect tensioning of different widths of cable ties



**Cable tie gun - Heavy duty**

Item Number	Length	Quantity
495004	4.7mm - 13mm	10

- Designed for automatic tensioning and trimming of cable ties
- Tension adjuster for the perfect tensioning of different widths of cable ties



**Cable tie gun**

Item Number	Length	Quantity
495003	2.4mm - 4.8mm	6

**DRAW TAPES**

- Special flexible spring steel for outstanding strength & reliability
- Integral braking system for non-slip cable pull through



**Electrician's draw tape cassette**

Item Number	Length	Quantity
495008	50ft / 15.2m	1

- Lead spring guide for smooth feed & minimal snagging
- Special 'Perlon' tape for strength & reliability

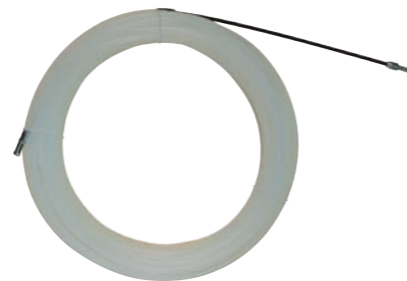

**Electrician's draw tape**

Item Number	Length	Quantity
495005	10m	3
495006	20m	3
495007	30m	3

**SWITCH KEYS**

- PH2 screwdriver bit included

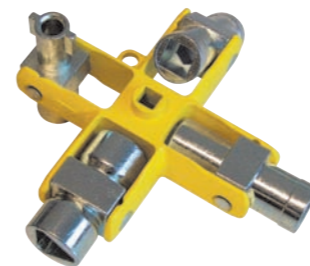

**Switch key - Universal 9 in 1**

Item Number	Icons	Quantity
T4451-2	[Icons]	6

- Compact pen-style design offering 7 key types
- Tough glass reinforced nylon construction - strong & light weight
- Modulo size 2 screwdriver bit included



**Switch key - Universal 7 in 1**

Item Number	Icons	Quantity
T4451-1	[Icons]	6

- 6mm bit driver adapter & double ended screwdriver bit included



**Switch key - Universal 8 in 1**

Item Number	Icons	Quantity
495015	[Icons]	10
495002	[Icons]	10

- High quality, heavy duty construction for professional use
- Long life tips suitable for use with lead free solder
- Individually tested to 10,000V for safe live working up to 1,000V



**Soldering irons**

CE, GS, ROHS 2002/95/EC, VDE0682/201, WEEE 2002/96/EC



Item Number	Power	Plug Type	Quantity
495009	soldering iron 25W	UK 3-pin plug	1
495010	soldering iron 40W	UK 3-pin plug	1
495011	soldering iron 25W	Euro 2-pin plug	1
495012	soldering iron 40W	Euro 2-pin plug	1
495013	spare tip set for 25W	-	1
495014	spare tip set for 40W	-	1

- For the fast and secure seating of data wires into terminals - suitable for a wide range of terminal block types
- One step action for automatic seating & trimming of excess wires
- Handle includes wire extractor hook & spudger



**Punch down tool**

Item Number	Length	Quantity
495033	180mm 7"	3

- Precision ground, HSS tap for a clean, accurate cut & long life
- 50mm tap length for improved access
- Shatter resistant acetate handle for damage protection



**Re-threading tools**

Item Number	Thread	Length	Quantity
495028	M3.5	0.6	12
495029	M4	0.7	12

**HAMMERS**

HÄMMER  
MARTEAUX  
MARTILLOS

60-63

**WRECKING TOOLS**

ABRISSWERKZEUGE  
OUTILS DE DÉMOLITION  
HERRAMIENTAS DE DEMOLICIÓN

63

**CHISELS & BOLSTERS**

MEißEL UND BREITEISEN  
BURINS ET CISEAUX  
CINCELES PARA MADERA Y MAMPOSTERÍA

64-65

**PROFESSIONAL SOFT GRIP TROWELS**

PROFESSIONELLE KELLEN MIT WEICHEM GRIFF  
TRUELLES PROFESSIONNELLES AVEC POIGNÉE À REVÊTEMENT SOUPLE  
PALETAS DE AGARRE SUAVE PARA PROFESIONALES

66

**TRADITIONAL HARD WOOD TROWELS**

TRADITIONELLE HARTHOLZSPACHTELN  
TRUELLES TRADITIONNELLES À POIGNÉE EN BOIS DUR  
PALETAS CON MANGO DE MADERA

66-67

**STAINLESS STEEL TROWELS**

EDELSTAHLKELLEN  
TRUELLES EN ACIER INOXYDABLE  
PALETAS DE ACERO INOXIDABLE

68

**PLASTERING TOOLS**

VERPUTZWERKZEUGE  
OUTILS DE PLÂTRERIE  
HERRAMIENTAS DE ENYESADO

68-69

**PADDLE & MIXERS**

SCHAUFEL UND MISCHER  
MÉLANGEUR ET MALAXEURS  
PALETAS Y MEZCLADORES

69

**INSPECTION LAMPS**

INSPEKTIONSLAMPEN  
BALADEUSES  
LÁMPARAS DE INSPECCIÓN

70

**PLUMBING**

KLEMPNERARBEITEN  
PLOMBERIE  
FONTANERÍA

70-71

**TILING & GLAZING**

FLIESENLEGEN UND VERGLASEN  
CARRELAGE ET VITRAGE  
AZULEJOS Y CRISTALES

72

**SCRAPERS & FILLING KNIVES**

SCHABER UND KROPFSPACHTEL  
GRATTOIRS ET COUTEAUX À ENDUIRE  
RASPADORES Y ESPÁTULAS PARA RELLENADO

73

**STAPLE GUNS**

TACKER  
AGRAFEUSES  
PISTOLAS GRAPADORAS

74-75

**GLUE GUNS**

KLEBEPISTOLEN  
PISTOLETS À COLLE  
PISTOLAS DE COLA

75

# BUILDING & PLUMBING

BAU UND SANITÄRINSTALLATION  
BÂTIMENT ET PLOMBERIE  
CONSTRUCCIÓN Y FONTANERÍA



# ANTI-VIBRATION HAMMERS

## ANTI-VIBRATIONS-HÄMMER

## MARTEAUX ANTI-VIBRATIONS

## MARTILLOS ANTIVIBRACIÓN



- 1 Single piece drop forged high carbon steel head & shaft - hardened & tempered for superior strength & durability**  
Aus einem Stück gesenkgeschmiedeter Kopf und Stiel aus hochlegiertem Kohlenstoffstahl - gehärtet und angelassen für überragende Festigkeit und Dauerhaftigkeit  
Tête et manche d'une seule pièce en acier à haute teneur en carbone matricé - trempé pour une résistance et une durabilité excellentes  
Cabeza y mango forjados de acero de alto contenido de carbono en una sola pieza, endurecida y templada para mayor resistencia y durabilidad
- 2 Balanced weight design with energy saving claw geometry for improved performance**  
Ausbalanciertes Gewicht mit Energie sparender Klauengeometrie für verbesserte Leistung  
Conception assurant l'équilibrage des poids avec géométrie de panne fendue à économie d'énergie pour un meilleur rendement  
Diseñados para obtener un peso equilibrado con geometría de orejas optimizada para el ahorro de tiempo y esfuerzo, mejorando así el rendimiento
- 3 Contoured anti-vibe shock absorbing grip system to protect against injury through shock**  
Anti-Vibe Schock absorbierendes Dämpfungssystem, um Verletzungen beim Schlagen zu vermeiden  
Système de préhension profilé anti-vibrations et antichocs pour protéger l'utilisateur des lésions occasionnées par les chocs  
Sistema de amortiguado antivibración con agarre contorneado para evitar las lesiones al golpear
- 4 Polished & lacquered to protect against corrosion**  
Poliert und lackiert zum Schutz gegen Korrosion  
Finition polie et laquée pour la protection contre la corrosion  
Pulidos y barnizados para proteger contra la corrosión



### HAMMERS

- See adjoining feature page



#### Claw hammers - Anti-vibration one piece forged

Item Number		
357001	454g 16oz	6
357002	568g 20oz	6

- Single piece drop forged high carbon steel head & shaft - hardened & tempered for superior strength and durability
- Contoured anti-vibe shock absorbing grip system to protect against injury from transmitted shock
- Polished and lacquered to protect against corrosion



#### Club hammer - Anti-vibration one piece forged

Item Number		
357005	1361g 3lb	2

- Drop forged high carbon steel head - hardened & tempered for superior strength and durability
- Tough fibreglass shaft for strength
- Contoured anti-vibe shock absorbing grip system to protect against injury from transmitted shock
- Polished and lacquered to protect against corrosion



#### Claw hammers - Anti-vibration fibreglass shaft

Item Number		
357003	454g 16oz	6
357004	568g 20oz	6

- Drop forged high carbon steel head - hardened & tempered for superior strength and durability
- Tubular steel shaft - strong & lightweight
- Hi-vis handle for increased visibility in low light conditions
- Black lacquered to protect against corrosion



#### Claw hammers - Hi-vis

Item Number		
T4229 08	227g 8oz	6
T4229 16	454g 16oz	6
T4229 20	568g 20oz	6

- Drop forged high carbon steel head - hardened & tempered for superior strength and durability
- Black lacquered to protect against corrosion
- Tough hickory shaft to withstand high impact applications



#### Club hammers

Item Number		
T4219 40	1135g 2½lb	2
T4219 64	1816g 4lb	2

- Drop forged high carbon steel head - hardened & tempered for superior strength and durability
- Black lacquered to protect against corrosion
- Traditional ash shaft



#### Club hammers - German pattern

Item Number		
T4219A 10	1000g 2¼lb	6
T4219A 15	1500g 3½lb	6

- Drop forged high carbon steel head - hardened & tempered for superior strength and durability
- Vibration damping fibreglass shaft for strength & protection
- Rubber overstrike collar protects against damage & transmitted shock



### Sledge hammers

Item Number	Weight	Quantity
T421808	3.63kg 8lb	2
T421812	5.44kg 12lb	2

- Drop forged high carbon steel head - hardened & tempered for superior strength and durability
- Accurately ground chisel end for clean cutting
- Tubular steel shaft - strong & lightweight



### Brick hammers

Item Number	Weight	Quantity
T4232 16	454g 16oz	4
T4232 20	568g 20oz	4

- Drop forged high carbon steel head - hardened & tempered for superior strength and durability
- Tubular steel shaft - strong & lightweight



### Mortar pick

Item Number	Description	Quantity
T4234	chisel and point	6

- Drop forged high carbon steel head - hardened & tempered for superior strength and durability
- Black lacquered to protect against corrosion
- Tough hickory shaft for durability
- Cross pein for easy starting of small nails & pins



### Pin hammer

Item Number	Weight	Quantity
T4203	114g 4oz	3

- Drop forged high carbon steel head - hardened & tempered for superior strength and durability
- Black lacquered to protect against corrosion
- Tough hickory shaft for durability
- Cross pein for easy starting of small nails & pins



### Joiner's hammers

Item Number	Weight	Quantity
T4204 06	171g 6oz	3
T4204 08	227g 8oz	3
T4204 10	284g 10oz	3

- Drop forged high carbon steel head - hardened & tempered for superior strength and durability
- Black lacquered to protect against corrosion
- Tough hickory shaft for durability
- Ball pein for setting rivets



### Ball pein hammers

Item Number	Weight	Quantity
T4208H 08	227g 1/2lb	3
T4208H 16	454g 1lb	3
T4208H 24	682g 1 1/2lb	3
T4208H 32	908g 2lb	3

- Drop forged high carbon steel head - hardened & tempered for superior strength and durability
- Black lacquered to protect against corrosion
- Traditional ash shaft for strength



### Electrician's hammer - French pattern

Item Number	Weight	Quantity
356001	200g 7oz	12

- Drop forged high carbon steel head - hardened & tempered for superior strength and durability
- Black lacquered to protect against corrosion
- Traditional ash shaft for strength



### Engineer's hammer - French pattern

Item Number	Weight	Quantity
356002	300g 10 1/2 oz	12

- Drop forged high carbon steel head - hardened & tempered for superior strength and durability
- Black lacquered to protect against corrosion
- Traditional ash shaft for strength



### Engineer's hammers - German pattern

DIN 1041

Item Number	Weight	Quantity
T4227A 0100	100g 3 1/2 oz	12
T4227A 0200	200g 7oz	12
T4227A 0300	300g 10 1/2 oz	12
T4227A 0500	500g 17 1/2 oz	12
T4227A 1000	1000g 35oz	6

## WRECKING TOOLS

- Forged spring steel for strength and durability
- Specially contoured & notched for efficient nail pulling and prying
- Sharp angle ground ends for effective chiseling & scraping



### Prybar, nail puller & scraper

Item Number	Length	Quantity
T4310	380mm 15"	6

- High grain carbon steel, hardened and tempered for strength and durability
- Chisel end & goose neck end with nail pulling notch ideal for heavy duty levering and dismantling work



### Wrecking bars

Item Number	Length	Quantity
T431418	455mm 18"	1
T431424	610mm 24"	1

- Single piece forged spring steel construction for strength & durability
- Slim blade design with double sided hooked blades for fast & effective nail cutting



### Slater's ripper

Item Number	Quantity
T5180	1



## CHISELS & BOLSTERS

- Hand guard for increased comfort & protection from overstrike



### Brick bolsters - With grip

BS 3066

Item Number	Length	Head Width	Quantity
T3087S 3	230mm 9"	75mm 3"	10
T3087S 4	230mm 9"	100mm 4"	10



### Brick bolsters

BS 3066

Item Number	Length	Head Width	Quantity
T3087 3	230mm 9"	75mm 3"	10
T3087 4	230mm 9"	100mm 4"	10

- Hand guard for increased comfort & protection from overstrike



### Electrician's bolster - With grip

BS 3066

Item Number	Length	Head Width	Quantity
T3086S	225mm 8 3/4"	55mm 2 1/4"	10



### Electrician's bolster

BS 3066

Item Number	Length	Head Width	Quantity
T3086	225mm 8 3/4"	55mm 2 1/4"	10

- Angled & grooved cutting edge for the effective removal of mortar & cement



### Plugging chisel

BS 3066

Item Number	Length	Head Width	Quantity
T3088	250mm 10"	25mm 1"	10

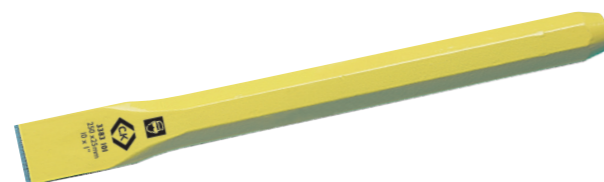

### Cold chisels

BS 3066

Item Number	Length	Head Width	Quantity
T3383 06	150mm 6"	12mm 1/2"	10
T3383 07	180mm 7"	16mm 5/8"	10
T3383 08	200mm 8"	19mm 3/4"	10
T3383 10	250mm 10"	19mm 3/4"	10
T3383 101	250mm 10"	25mm 1"	10
T3383 12	300mm 12"	25mm 1"	10
T3383 18	460mm 18"	19mm 3/4"	10

- High quality carbon steel, hardened & tempered for strength & durability
- Replaceable chisel bits



### Scutch chisel

BS 3066

Item Number	Head Width	Quantity
406001	25mm 1"	3
406002	38mm 1 1/2"	3

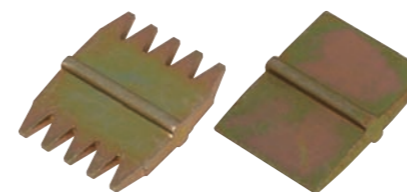

### Scutch chisel - Spare bits

Item Number	Head Width	Bit Type	Quantity
T4211/1	25mm 1"	scutch combs	10
T4211/2	25mm 1"	scutch droves	10
T4211/3	38mm 1 1/2"	scutch combs	10
T4211/4	38mm 1 1/2"	scutch droves	10

CONTENTS: 7 x plugging chisels. 7 x electrician's bolster chisels. 6 x bolster chisels, sizes: 75 & 100mm. 3 x bolster chisels with grip, size: 100mm.



### Bolster chisels display

BS 3066

Item Number	Description	Quantity
T3090LS	stock and stand	1

CONTENTS: 8 x cold chisels, size: 12 x 150mm. 7 x cold chisels, size: 16 x 180mm. 6 x cold chisels, sizes: 19 x 200 & 19 x 250mm. 5 x cold chisels, sizes: 25 x 250 & 25 x 300mm.



### Cold chisels display

BS 3066

Item Number	Description	Quantity
T3389LS	stock and stand	1

## PROFESSIONAL SOFT GRIP TROWELS

- High carbon steel blade, hardened & taper ground for the optimum balance of strength & flexibility
- Heavy duty tang welded to blade for strength & durability
- Patented soft grip handle with finger guard for comfort & control



Brick trowel - Broad heel

Item Number	Length	Quantity
T529510	255mm 10"	3



Brick trowel - Philadelphia

Item Number	Length	Quantity
T529311	280mm 11"	3



Pointing trowel

Item Number	Length	Quantity
T529606	150mm 6"	3



Gauging trowel

Item Number	Length	Quantity
T529207	180mm 7"	6



Finger trowel

Item Number	Length	Quantity
T529750	175 x 13mm 7" x 1/2"	3

## TRADITIONAL HARD WOOD TROWELS

- High carbon steel blade, hardened & taper ground for the optimum balance of strength & flexibility
- Heavy duty tang welded to blade for strength & durability
- Traditional wooden handle



Brick trowel - Broad heel

Item Number	Length	Quantity
T527010	250mm 10"	6
T527011	275mm 11"	3



Brick trowel - Philadelphia

Item Number	Length	Quantity
T527111	275mm 11"	1



Pointing trowels

Item Number	Length	Quantity
T5060 4	100mm 4"	3
T5060 5	125mm 5"	3
T5060 6	150mm 6"	6



Gauging trowel

Item Number	Length	Quantity
T527207	175mm 7"	3

- T5073 1 with half round blade



Finger trowels

Item Number	Length	Blade Width	Quantity
T5073 37	175mm 7"	10mm 3/8"	3
T5073 50	175mm 7"	13mm 1/2"	3
T5073 62	175mm 7"	16mm 5/8"	3
T5073 75	175mm 7"	19mm 3/4"	3
T5073 99	175mm 7"	25mm 1"	3
T5073 1	175mm 7"	13mm 1/2"	3



Margin trowel

Item Number	Length	Quantity
T5273	125mm 5"	3

- Welded & riveted tang to blade joint for outstanding durability



Flooring trowel

Item Number	Length	Quantity
T5264	405 x 115mm 16 x 4 1/2"	3

- Heavy duty carbon steel blade for strength
- 6 rivet blade joint for durability



Edging trowel

Item Number	Length	Quantity
T5274	280 x 115mm 11 x 4 1/2"	3

- Heavy gauge steel blade with tang welded to blade for strength & durability



Harling trowel

Item Number	Length	Quantity
T5097	165 x 165mm 6 1/2 x 6 1/2"	2

## STAINLESS STEEL TROWELS

- Stainless steel blade for corrosion protection & low maintenance
- Heavy duty tang welded to blade for strength & durability
- Patented soft grip handle with finger guard for comfort & control



Brick trowel - Philadelphia

Item Number	Length	Quantity
T524111	280mm 11"	3

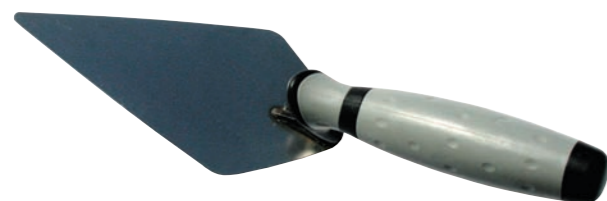

Pointing trowel

Item Number	Length	Quantity
T524306	150mm 6"	6

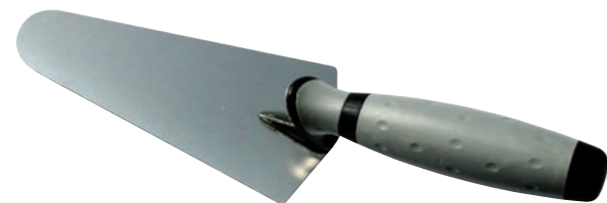

Gauging trowel

Item Number	Length	Quantity
T524207	175mm 7"	3

- Fully hardened & tempered carbon steel for wear resistance



Brick jointer

Item Number	Dimensions	Quantity
T5198	13 x 16mm 1/2 x 5/8"	12

## PLASTERING TOOLS

- High carbon steel blade, hardened & tempered for the optimum balance of strength & flexibility
- Welded & riveted tang to blade joint for outstanding durability
- Soft grip handle for comfort & control



Plasterer's trowel - Steel, soft grip

Item Number	Dimensions	Quantity
T5298	280 x 120mm 11 x 4 3/4"	6

- High carbon steel blade, hardened & tempered for the optimum balance of strength & flexibility
- Welded & riveted tang to blade joint for outstanding durability
- Traditional wooden handle



Plasterer's trowel - Steel

Item Number	Dimensions	Quantity
T5068	280 x 120mm 11 x 4 3/4"	6

- Stainless steel blade for corrosion protection & low maintenance
- Welded & riveted tang to blade joint for outstanding durability
- Traditional wooden handle



Plasterer's trowel - Stainless steel

Item Number	Dimensions	Quantity
T5072	280 x 120mm 11 x 4 3/4"	6

- Stainless steel blade for corrosion protection & low maintenance
- Welded & riveted tang to blade joint for outstanding durability
- Traditional wooden handle



Plasterer's trowel - Stainless steel, large

Item Number	Dimensions	Quantity
T5299	330 x 120mm 13 x 4 3/4"	6

- Lightweight aluminium blade with grooved, non-slip surface

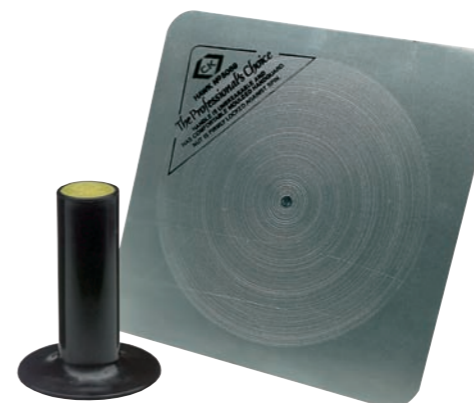

Plasterer's hawk

Item Number	Dimensions	Quantity
T5069	300 x 300mm 12 x 12"	3

- Lightweight, moulded foam polymer with fine chequered working face - durable & non-warping



Skimmer floats

Item Number	Dimensions	Quantity
T5172	280 x 140mm	1
T5172 18	320 x 180mm	1

- Solid forged steel blade, hardened, tempered & ground for the optimum balance of flexibility & strength



Trowel & square tools

Item Number	Length	Blade Width	Quantity
T5093 50	265mm 10 1/2"	12mm 1/2"	3
T5093 62	265mm 10 1/2"	16mm 5/8"	3
T5093 75	265mm 10 1/2"	19mm 3/4"	3

- Solid forged steel blade, hardened, tempered & ground for the optimum balance of flexibility & strength



Leaf & square tool

Item Number	Length	Blade Width	Quantity
T5091 50	200mm 8"	12mm 1/2"	3

## PADDLE & MIXERS

- Steel & cast aluminium construction - strong & light weight



Plasterer's paddle

Item Number	Length	Quantity
T1885	790mm 31"	1

- Nickel plated steel construction for strength & easy cleaning
- Suitable for use with electric drills at speeds between 200 - 700 rpm



Drill mixers

Item Number	Length	Quantity
T1881	420mm 16 1/2"	2
T1882	620mm 25"	2

## INSPECTION LAMPS

- Heavy duty steel cage & glass for damage protection
- Suspension hook for convenience
- 5m cable for long reach access
- Max 60W 240V screw-in bulb (not included)



### Inspection lamps

CE, ROHS 2002/95/EC, WEEE 2002/96/EC

Item Number			
T5901	U.K 3-pin plug	1	
T5901A	Euro 2-pin plug	1	

- Sealed 240V 8W fluorescent lamp with suspension hook for convenience
- 5m cable for long reach access



### Inspection lights

CE, ROHS 2002/95/EC, WEEE 2002/96/EC

Item Number			
T5902	U.K 3-pin plug	2	
T5902A	Euro 2-pin plug	2	

## PLUMBING

- Black lacquered die cast aluminium for strength & corrosion resistance
- Integral de-burring blade in the handle for convenience
- Replaceable hardened steel cutting wheel effortlessly cuts copper, brass, aluminium, and thin wall steel pipe
- With spare cutting wheel



### Pipe cutter - 3-30mm

Item Number			
T2231	3 - 30mm	5	

- Black lacquered die cast aluminium for strength & corrosion resistance
- Replaceable hardened steel cutting wheel effortlessly cuts copper, brass, aluminium, and thin wall steel pipe

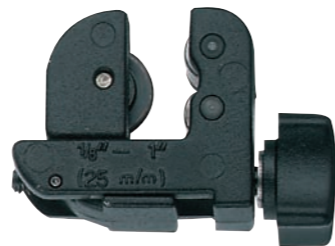

### Pipe cutter - 3-25mm

Item Number			
T2232	3 - 25mm	10	

- Suitable for T2231 & T2232 Pipe Cutters

### Pipe cutter - Spare wheel

Item Number			
T2235	19.5mm	10	

- Adjustable, telescopic wrench with sliding T handle for confined & long reach access
- Spring loaded, self adjusting jaws maintain an automatic grip
- 180° swivelling head for clockwise or anti-clockwise action
- Hardened steel jaws for durability



### Basin wrench

Item Number			
T4311	275 - 460mm	6	

- One piece steel construction for strength & durability
- Zinc plated for corrosion protection
- PVC handle for comfort and grip

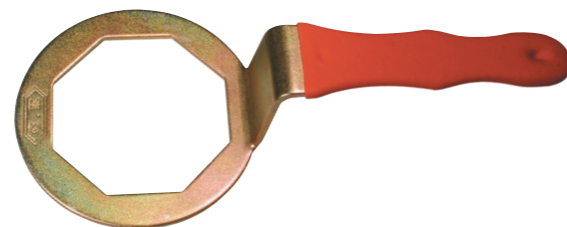

### Immersion heater spanner

Item Number			
T4347	85mm	6	

- Heavy duty aluminium body - strong & light
- Ratchet action razor sharp stainless steel blade for effortless cutting of; PVC conduit, blue water mains, plastic pipe, rubber hose, pneumatic pipe, electrical sleeving, etc.
- Complete with special adaptor for straight or mitre cutting of small rectangular cross-section trunking



### PVC pipe & conduit cutter - Ratchet

Item Number			
430003	220mm	32mm	3

- Heavy duty aluminium body - Strong & light
- Lever action razor sharp stainless steel blade for effortless cutting of; PVC conduit, blue water mains, plastic pipe, rubber hose, pneumatic pipe, electrical sleeving, wooden dowel, etc
- 5 interchangeable anvils (flat, double radius, single radius, 90° square and mitre) allow a variety of cross sections to be cut, both straight and mitred



### Multi cutter set

Item Number			
T2240			3

- Glass fibre reinforced polycarbonate body - strong & light
- Razor sharp stainless steel blade for efficient cutting of: PVC conduit, blue water mains, plastic pipe, rubber hose, pneumatic pipe, electrical sleeving, etc.



### PVC pipe & conduit cutter

Item Number			
430001	195mm	28mm	3

- High quality drop forged steel construction with hardened & tempered jaws for strength & durability
- Patented head design for high torque performance



### Stillson wrenches

Item Number			
T3735 300	300mm 12"	38mm	8
T3735 350	350mm 14"	55mm	8
T3735 450	450mm 18"	55mm	8
T3735 600	600mm 24"	70mm	4

- High quality drop forged steel construction, hardened & tempered for strength & durability



### Plumbing spanner - Double ended

DIN 895

Item Number			
T4381	255mm	24 x 32mm	3

- High quality drop forged steel construction, hardened & tempered for strength & durability



### Plumbing spanner - Single ended

DIN 894

Item Number			
T4382 039	300mm	39mm	3

## TILING & GLAZING

- Tungsten carbide tipped, suitable for tiles, metal and glass
- Pocket clip



### Tile scribe

Item Number	
T1531	12

- Polished carbon steel blade with welded ergonomic handle for comfort & control



### Adhesive trowels

Item Number				
T5169 1	255 x 115mm 10 1/4 x 4 1/2"	6mm 1/4"		10
T5169 2	255 x 115mm 10 1/4 x 4 1/2"	20mm 3/4"		10

- Lightweight, polymer handle bonded to a dense rubber pad - suitable for grout application



### Grouting float

Item Number		
T5174	280 x 140mm 11 x 5 1/2"	1

- Lightweight, polymer handle bonded to a sponge pad - suitable for washing down grout



### Grouting sponge

Item Number		
T5173	280 x 140mm 11 x 5 1/2"	1

- High quality with 6 premium quality tungsten carbide blades in turret head
- Oiled felt washer for constant lubrication



### Glass cutter

Item Number	
T5087	6

### Spare blades

Item Number		
T5089	x 12	1

- High quality spring steel blade for strength & flexibility
- Clip point profile for smoothing & shaping putty
- Rosewood handle



### Putty knife

Item Number	
T5076	1

- Lever action, double suction cup designed to lift up to 60kg

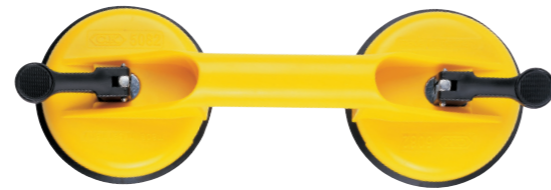

### Suction lifter - 60kg

Item Number			
T5082	320mm 12 1/4"	60kg	1

- Clamp action suction cup designed to lift up to 30kg



### Suction lifter - 30kg

Item Number			
T5081	120mm 4 3/4"	30kg	1

## SCRAPERS & FILLING KNIVES

- High quality, tapered ground spring steel blade for strength
- Rosewood handle



### Scrapers

Item Number		
T5075 1	25mm 1"	3
T5075 2	50mm 2"	3
T5075 3	75mm 3"	3
T5075 4	100mm 4"	3

- High quality, thin, tapered ground spring steel blade for the optimum balance of strength & flexibility required for filling
- Rosewood handle



### Filling knife

Item Number		
T5077 3	75mm 3"	6

- Tapered ground spring steel blade for strength & flexibility
- Plastic wipe clean handles with hanging hole for convenient storage



### Scraper / filling knives

Item Number		
T5070A 040	40mm 1 1/2"	6
T5070A 050	50mm 2"	6
T5070A 070	70mm 2 3/4"	6
T5070A 100	100mm 4"	6

CONTENTS: 6 x sizes: 40, 50, 70 & 100mm.



### Scraper / filling knife display stand

Item Number		
T5070A/4LS	stock and stand	1

- Super flexible spring steel construction designed for removing paint from glass, filling, etc.
- Fitted with plastic hand guards for safety



### Scraper set - 4 Piece superflex

Item Number		
T5064	50, 80, 100 and 120mm	1

## STAPLE GUNS

- Heavy duty, tough cast aluminium body for strength & durability
- Bi-material ergonomic handle for comfort & reduced fatigue
- Unique staple loading & clearing mechanism for fast & convenient use
- Handle safety locking system prevents accidental operation

- Fires staples 6-14mm (interchangeable with Arrow T50 or Rapid 140 6-14mm) & nails (brads) 18 gauge 16mm
- Supplied with 200 x 8mm staples



### Staple & nail gun

Item Number		
496001		3

- Fires half round staples for use on low voltage cable max 7.5mm diameter (interchangeable with Arrow T25).



### Cable tacker - Low voltage cable

Item Number		
T6227	7.5mm	3

- Fires half round staples for use on telecom data cable max 4.8mm diameter



### Cable tacker - Telecom cable

Item Number		
T6228	4.8mm	3

- High quality steel cable staples, galvanised for corrosion protection - to suit C.K T6227 cable tacker

### Cable staples - Half round

Item Number		
495021	7.5 x 10mm	10
495022	7.5 x 14mm	10

- High quality steel staples, galvanised for corrosion protection - to suit C.K 496001 heavy duty staple gun

### Staples - Square

Item Number		
496002	10.5 x 8mm	10
496003	10.5 x 10mm	10
496004	10.5 x 12mm	10
496005	10.5 x 14mm	10

- High quality telecom cable staples, galvanised for corrosion protection
- White coated tops for discreet fixing - to suit C.K T6228 Telecom cable tacker

### Telecom staples - Half round

Item Number		
495024	4.8 x 10mm	10

CONTENTS: 4 x Staple & nail guns. 3 x boxes of square staples, sizes: 8, 10, 12 & 14mm.



### Stapler display

Item Number		
T6222-LS	stock and stand	1

CONTENTS: 2 x Low voltage cable tacker. 2 x telecom cable tacker. 3 x boxes of half round cable staples, sizes: 10 & 14mm. 7 x boxes of half round telecom staples, size: 10mm.



### Cable tacker display

Item Number		
T6224-LS	stock and stand	1

## GLUE GUNS

- Premium quality with high energy heater for fast heating & improved glue flow
- Heat insulated nozzle for safety
- Glue output of up to 21g/min for fast application
- Supplied with two 100x11mm general purpose glue sticks



### Glue gun

CE, ROHS 2002/95/EC, WEEE 2002/96/EC

Item Number		
T6215	UK 3 pin plug	6
T6215A	Euro 2 pin plug	6

CONTENTS: Glue gun. 12 x glue sticks, size: 200mm. Carry case.



### Glue gun kit

CE, ROHS 2002/95/EC, WEEE 2002/96/EC

Item Number		
T6216	Euro 2 pin plug	1

### Glue sticks

Item Number			
T6218 06	100mm	x 6	6
T6218 25	100mm	x 25	6
T6219 025	200mm	x 25	1
T6219 125	200mm	x 125	1

**GEL-GRIP**

GEL-GRIP  
GEL-GRIP  
GEL-GRIP

78-80

**TAPE MEASURES**

BANDMAßE  
MÈTRES À RUBAN  
CINTAS MÉTRICAS

81

**RULES**

LINEALE  
RÈGLES  
REGLAS

82

**SPIRIT LEVELS**

WASSERWAAGEN  
NIVEAUX À BULLE  
NIVELES

83

**CHALK, LINES & ACCESSORIES**

KREIDE, SCHNÜRE UND ZUBEHÖR  
CRAIE, CORDEAUX ET ACCESSOIRES  
TIZA, LÍNEAS Y ACCESORIOS

83

**JOINER'S SQUARES & BEVELS**

SCHREINER-WINKEL UND -SCHMIEGEN  
ÉQUERRES DE MENUISIER ET FAUSSES-ÉQUERRES  
ESCUADRAS DE CARPINTERO Y TRANSPORTADORES DE ÁNGULOS

84

**COMBINATION SQUARES**

KOMBINATIONSWINKEL  
ÉQUERRES COMBINÉES  
ESCUADRAS UNIVERSALES

85

**VERNIER CALIPER**

MESSSCHIEBER  
PIED À COULISSE  
CALIBRADOR VERNIER

85

**FEELER GAUGE**

FÜHLERLEHREN  
JAUGES D'ÉPAISSEUR  
GALGAS

85

**POCKET BALANCE**

FEDERZUGWAAGE  
BALANCES DE POCHE  
BÁSCULAS DE BOLSILLO

85

# MEASURING & MARKING

MESSEN & MARKIEREN  
MESURE & MARQUAGE  
MEDICIÓN Y MARCADO

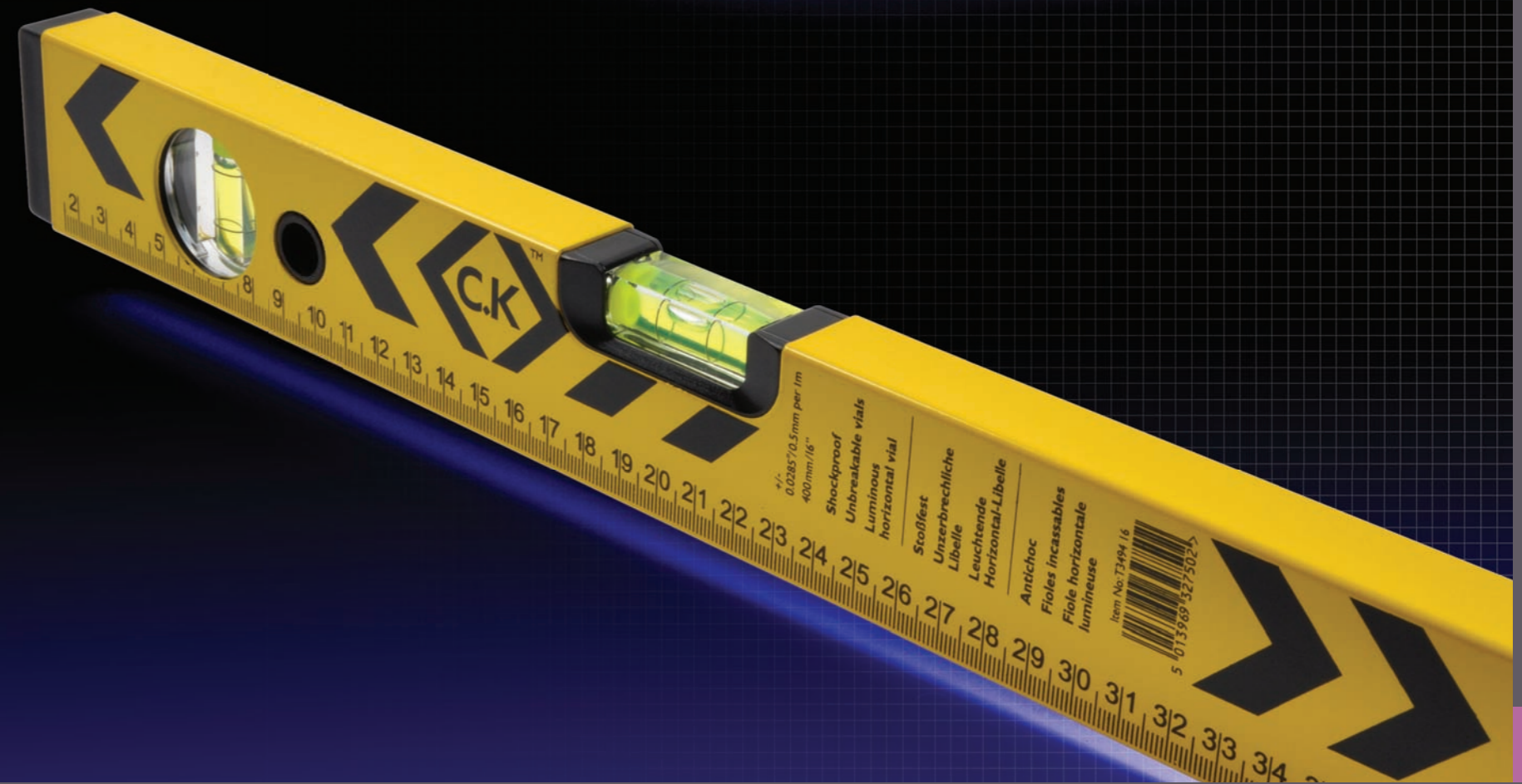
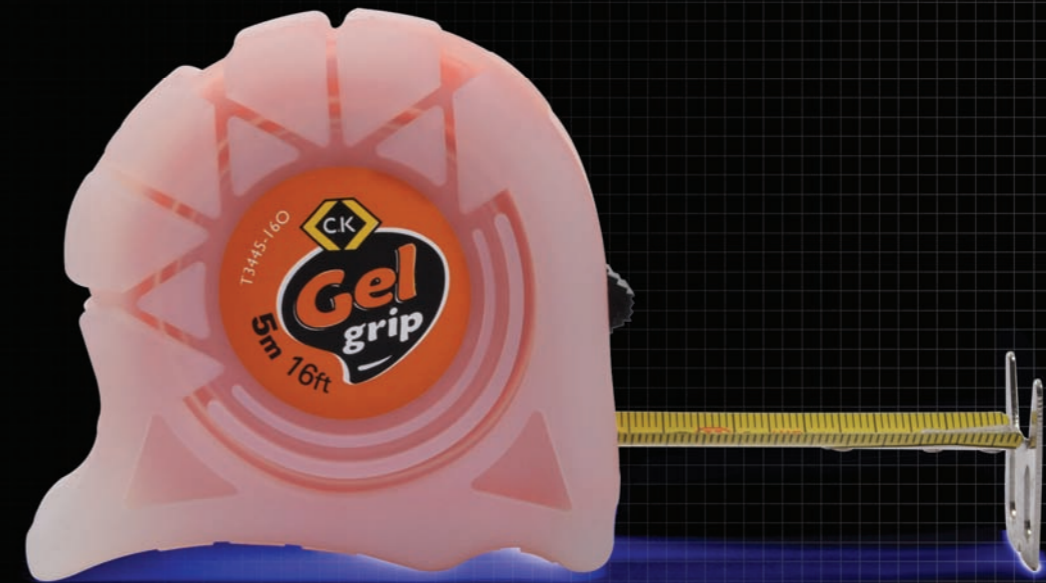

# GEL-GRIP

## ADVANCED TAPE TECHNOLOGY

FORTSCHRITTLICHE TECHNIK  
MÈTRES À RUBAN TECHNOLOGIQUEMENT ÉVOLUÉS  
TECNOLOGÍA AVANZADA DE CINTAS



**1 Gel-grip jacket provides exceptional comfort with outstanding damage protection**

Gel-grip Gehäuse bietet außergewöhnlichen Komfort mit überragendem Beschädigungsschutz  
Corps en gel procure un confort exceptionnel avec une protection remarquable contre les chocs  
La carcasa Gel-grip proporciona un confort excepcional con protección excelente contra daños

**2 Specially designed end hook grips on the top, bottom & side**

Speziell entworfener Endhaken greift oben, unten und seitlich  
Crochet d'extrémité spécialement conçu s'accroche sur le dessus, au-dessous et sur le côté  
Cuenta con gancho especialmente diseñado para enganchar por la parte superior, inferior y lateral

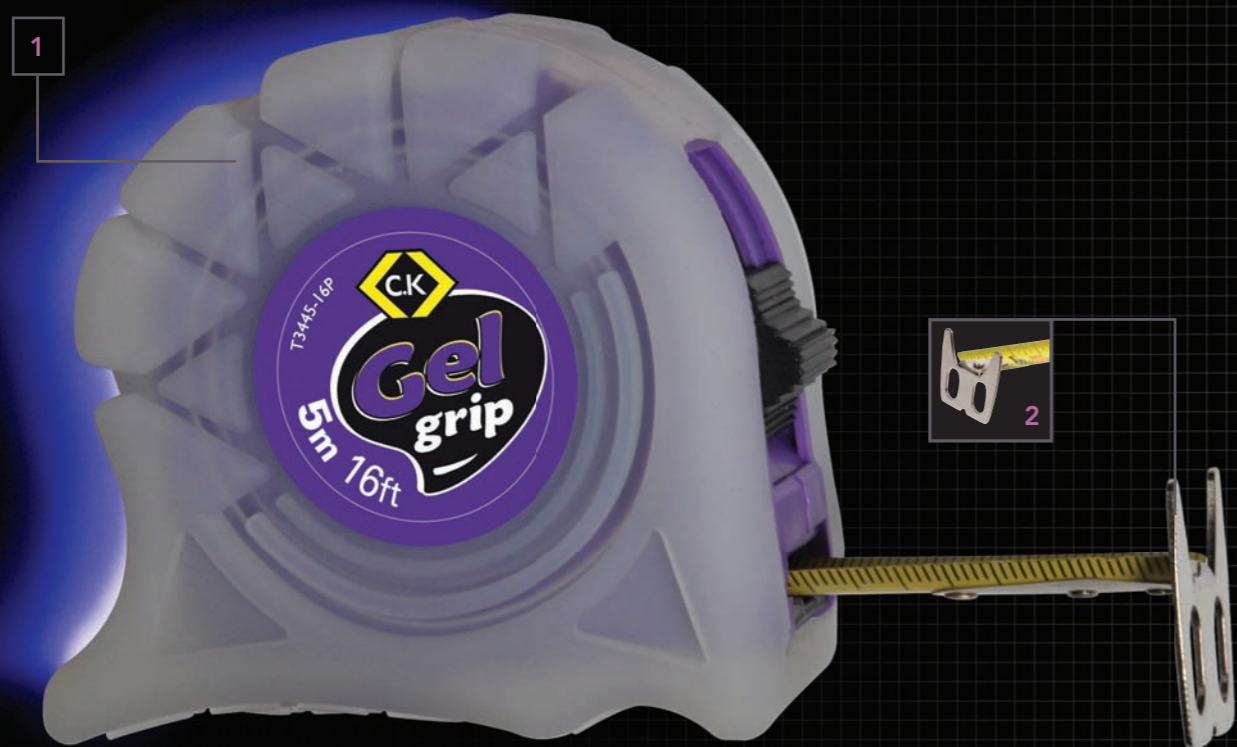

### OVERHEAD MEASURING

ÜBERKOPF MESSEN  
MESURAGE EN SURPLOMB  
MEDICIÓN ELEVADA



### VERTICAL MEASURING

VERTIKAL MESSEN  
MESURAGE VERTICAL  
MEDICIÓN VERTICAL



### SIDE MEASURING

SEITLICH MESSEN  
MESURAGE SUR LE CÔTÉ  
MEDICIÓN LATERAL



# DEVELOPED SPECIFICALLY FOR THE PROFESSIONAL TRADESMAN, THE C.K GEL-GRIP TAPE ENCOMPASSES THE VERY LATEST IN TAPE TECHNOLOGY

SPEZIFISCH FÜR DEN FACHMANN ENTWICKELT, UMFASST C.K GEL-GRIP DIE NEUESTEN TECHNOLOGIEN

SPÉCIFIQUEMENT ÉLABORÉ POUR LES UTILISATEURS PROFESSIONNELS, LE MÈTRE À RUBAN C.K GEL-GRIP INTÈGRE LES TOUTES DERNIÈRES ÉVOLUTIONS DE LA TECHNOLOGIE DES MÈTRES À RUBAN

DESARROLLADA ESPECÍFICAMENTE PARA LOS PROFESIONALES DEL SECTOR, LA CINTA C.K GEL-GRIP INCLUYE LO ÚLTIMO EN LA TECNOLOGÍA DE FLEXÓMETROS

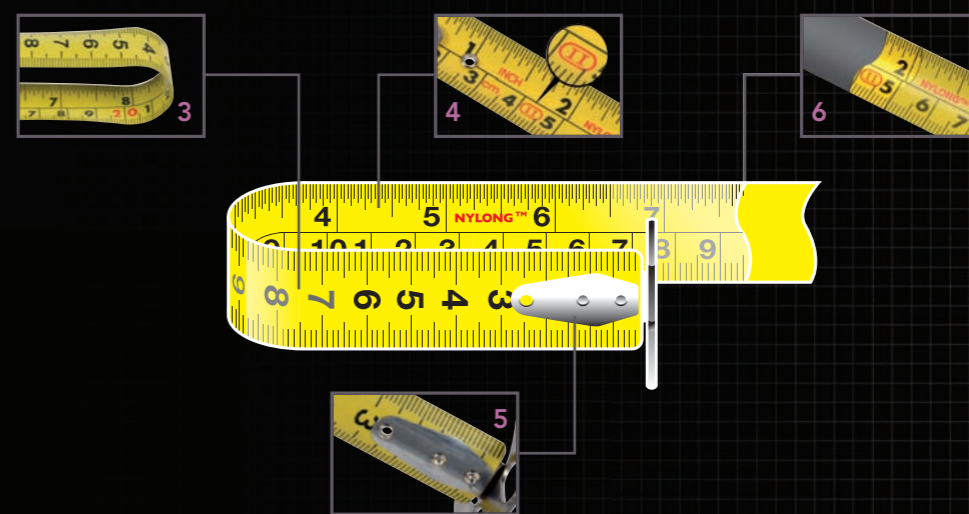

**3 Double sided marking for regular, overhead & vertical measuring**

Doppelseitige Markierung für normales, horizontal überkopf und vertikales Messen  
Marquage sur les deux faces pour les relevés de cotes classiques, en surplomb et verticaux  
Marcado en ambos lados para conseguir mediciones normales, elevadas y verticales

**4 EC Class II for greater measuring accuracy (accurate to 1mm over 3m)**

EC Klasse II für höhere Messgenauigkeit (1 mm über 3 m)  
CE classe II pour une plus grande exactitude de mesurage (précision de 1 mm sur 3 m)  
EC Clase II para una mayor exactitud de medición (precisión en 3m de 1 mm)

**5 Triple riveted hook prevents blade & hook damage on rewind**

Dreifach vernieteter Haken vermeidet Band- und Hakenbeschädigungen beim Zurückspulen  
Le triple rivetage du crochet empêche toute détérioration au rembobinage  
El gancho con triple remachado previene el daño producido en hoja y gancho durante el rebobinado

**6 NYLON™ coated blade for superior abrasion resistance & durability**

NYLON™-beschichtetes Band - überragend abriebresistent und hohe Dauerhaftigkeit  
Ruban à revêtement NYLON™ garantissant une excellente résistance à l'abrasion et une longue durabilité  
Cinta con recubrimiento NYLON™ para una resistencia superior a la abrasión y una mayor durabilidad

LACQUERED  
LACKIERT  
LAQUÉ  
LACADA

NYLON™



**Results of a stringent 15 litre sand blast test.**

Ergebnis eines stringenten 15 Liter Sandblastest.  
Résultats d'un essai rigoureux de sablage à 15 litres.  
Resultados conseguidos mediante una rigurosa prueba con 15 litros de chorro de arena.



## GEL-GRIP

- Fully featured tape measure - see previous feature page



### Gel-grip tapes - 5m / 16ft

2004/22/EC Class 2

Item Number		i	
T3445-16B	19mm	blue	6
T3445-16G	19mm	green	6
T3445-16O	19mm	orange	6
T3445-16P	19mm	purple	6
T3445-16R	19mm	red	6



### Gel-grip tape - 7.5m / 25ft

2004/22/EC Class 2

Item Number		i	
T3445-25	25mm	orange	6

CONTENTS: 4 x blue, orange & green Gel-grip tapes, size 5m/16ft.



### Gel-grip tapes display

2004/22/EC Class 2

Item Number		i	
T3445-16-CBOX	stock & display		1

CONTENTS: 4 x blue, orange & green Gel-grip tapes, size 5m/16ft.

### Gel-grip tapes display refill pack

2004/22/EC Class 2

Item Number		i	
T3445-16-RFIL	stock only		1

## TAPE MEASURES

- Tough ABS plastic body for damage protection
- Full lock & pause buttons for control
- Belt clip for convenience
- NYLONG™ coated blade for superior abrasion resistance & durability
- 16" & 400mm joist centre markings for fast marking out
- True zero hook for accurate external & internal measurements
- Integral recoil damper for hook damage protection



### ST tape measures

2004/22/EC Class 2

Item Number			i	
T3442 10	3m 10ft	metric/imperial		6
T3442 16	5m 16ft	metric/imperial		6
T3442 25	7.5m 25ft	metric/imperial		6
T3442M 3	3m	metric		6
T3442M 5	5m	metric		6
T3442M 8	8m	metric		6

- Tough steel case for damage protection
- Fold out blade hook for secure anchoring
- Hand strap for convenient carrying
- Fold out winding handle for rapid rewind & safe storage
- Nylon coated steel tape - extremely strong & stretch resistant
- Double sided metric/imperial graduations

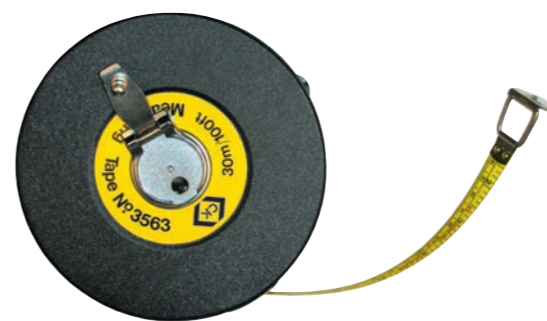

### Measuring tape - Steel

2004/22/EC Class 3

Item Number				
T3563 100	30m 100ft	13mm 1/2"		3

- Tough ABS plastic body for damage protection
- Fold out blade hook for secure anchoring
- Hand strap for convenient carrying
- Fold out winding handle for rapid rewind & safe storage
- Glassfibre reinforced tape - strong & stretch resistant
- Double sided metric/imperial graduations



### Measuring tape - Fibreglass

2004/22/EC Class 3

Item Number				
T3561 100	30m 100ft	13mm 1/2"		3

- Tough ABS plastic body for damage protection
- Integral ground spike & fold out blade hook for secure anchoring
- Soft grip handle for comfortable carrying
- Fold out winding handle for rapid rewind & safe storage
- Glassfibre reinforced tape - strong & stretch resistant
- Double sided metric/imperial graduations



### Surveyor's tapes

2004/22/EC Class 3

Item Number				
T3565 100	30m 100ft	13mm 1/2"		3
T3565 165	50m 165ft	13mm 1/2"		3
T3565 330	100m 330ft	13mm 1/2"		3

## RULES

- Stainless steel for corrosion protection
- Permanent indented markings for wear resistance
- Fine graduations for accurate measurements



### Steel rules - Metric/imperial

Item Number	Length	Thickness	Quantity
T3530 06	150mm 6"	18mm	6
T3530 12	300mm 12"	25mm	6

- High quality construction with brass hinges & end caps for durability
- Four fold design for compact storage
- Permanent indented markings for wear resistance



### Wooden rule - Metric/imperial

Item Number	Length	Quantity
T3510	1m 3ft	6

- Anodised aluminium construction with a strong plastic handle - lightweight, easy clean
- Metric graduations
- Ideal for cutting, measuring and marking out



### Straight edge/rule

Item Number	Length	Quantity
T3531 100	1000mm 40"	1

## SPIRIT LEVELS

- Powder coated, box section aluminium - strong, light & durable
- Shockproof, unbreakable vials, guaranteed leakproof for three years
- Luminous horizontal vial for low light conditions
- Precision manufactured, accurate to +/- 0.5mm per metre
- Metric measurement graduations for convenience
- 16" (400mm) & 24" (600mm) feature 1 vertical & 1 horizontal vial
- 32" (800mm) and above feature 2 vertical & 1 horizontal vials



### Aluminium box levels

Item Number	Length	Vials	Quantity
T3494 16	400mm 16"	2 vial with rule	1
T3494 24	600mm 24"	2 vial with rule	1
T3494 32	800mm 32"	3 vial with rule	1
T3494 40	1000mm 40"	3 vial with rule	1
T3494 48	1200mm 48"	3 vial	1
T3494 70	1800mm 70"	3 vial	1

- Tough ABS plastic body for damage protection
- V-groove base for pipework
- Magnetic base for steelwork
- Patented detachable mini level with magnetic base, ideal for setting patress boxes
- Also features string slots for use as line level
- 1 vertical & 1 horizontal vial



### Pocket level

Item Number	Length	Quantity
T3482	210mm 8 1/4"	5

## CHALK, LINES & ACCESSORIES

- Die cast aluminium construction - strong & lightweight
- Fold away winding handle for convenient storage
- Self chalking line with end attachment hook for ease of use
- Supplied with 60g of blue chalk



### Chalk line reel & chalk - Heavy duty

Item Number	Length	Quantity
T3520A	30m 100ft	6

- Tough plastic construction - strong & lightweight
- Fold away winding handle for convenient storage
- Self chalking line with end attachment hook for ease of use
- Supplied with 60g of blue chalk



### Chalk line reel & chalk

Item Number	Length	Quantity
T3522	30m 100ft	6

- Strong & absorbent cotton for effective retention of marking chalk



### Chalk line - Cotton

Item Number	Length	Quantity
T3517	18m 60ft	12

- Braided nylon construction - extra strong & durable



### Chalk line - Nylon

Item Number	Length	Quantity
T3519	18m 60ft	12

- High density chalk for clear marking results
- Plastic refill container with re-sealable dispenser cap



### Chalk powders

Item Number	Weight	Color	Quantity
T3521B 100	100g 4oz	blue	6
T3521R 100	100g 4oz	red	6

- Forged steel nickel plated for strength & corrosion resistance
- Suitable for use in wet & dry mortar



### Line pins

Item Number	Length	Quantity
T3490	170mm 6 1/2"	set of 2

- Conical, fully polished bob complete with screwed brass cord fitting



### Plumb bob

Item Number	Weight	Quantity
T3492 11	300g 11oz	3

## JOINER'S SQUARES & BEVELS

- Hardened & tempered blued steel blade for corrosion resistance
- Blade secured with three brass rivets & brass inside face for long term accuracy
- Hard rosewood stock



### Joiner's squares - Rosewood

Item Number	Length	Quantity
T3540 09	225mm 9"	3
T3540 12	300mm 12"	3

- Hardened & tempered blued steel blade for corrosion resistance
- Quick lock lever for convenient adjustment
- Hard rosewood stock



### Sliding bevel - Rosewood

Item Number	Length	Quantity
T3541 9	225mm 9"	4

- Screw pin adjustment for accurate & consistent setting of mortice & tenon joints
- Heavy brass inlays on marking faces for protection
- Hard rosewood body



### Marking & mortice gauge - Rosewood

Item Number	Length	Quantity
T3543	190mm 7½"	1

- Hardened & tempered blued steel blade for corrosion resistance
- Blade secured with three brass rivets & brass inside face for long term accuracy
- Beech stock



### Joiner's square - Beech

Item Number	Length	Quantity
T3533 09	225mm 9"	3

- Hardened & tempered blued steel blade for corrosion resistance
- Beechwood stock



### Sliding bevel - Beech

Item Number	Length	Quantity
T3537 09	230mm 9"	3

- Thumbscrew adjustment for accurate & consistent marking
- Brass inlays on marking faces for protection
- Beechwood body



### Marking gauge - Beech

Item Number	Length	Quantity
T3542A	240mm 9½"	3

- Traditional rectangular leaded carpenters pencil



### Carpenter's pencil

Item Number	Quantity
T1125 24	72

## COMBINATION SQUARES

- Stainless steel rule for corrosion protection
- Permanent indented markings for wear resistance

- Heavy duty, 3 in 1 construction for a complete marking & measuring solution

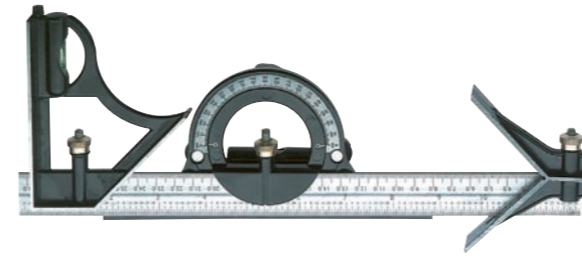

### Combination square - 3 in 1

Item Number	Length	Scale	Quantity
T3579	300mm 12"	metric/imperial	1

- Heavy duty construction for strength & durability

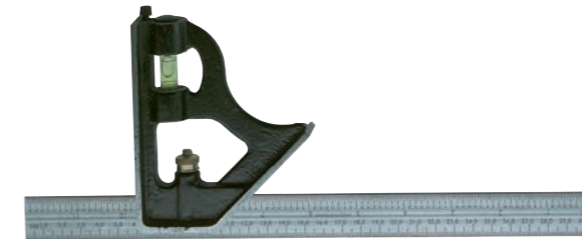

### Combination square - Heavy duty

Item Number	Length	Scale	Quantity
T3581	300mm 12"	metric/imperial	3

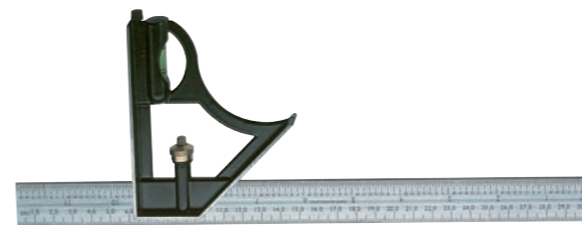

### Combination square

Item Number	Length	Scale	Quantity
T3582	300mm 12"	metric/imperial	3

- Roller adjustment along metric & imperial graduated rule for convenience
- Nickel plated for corrosion protection

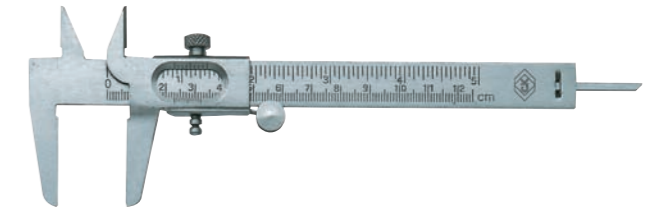

### Vernier caliper

Item Number	Length	Scale	Quantity
T3451	125mm 5"	metric/imperial	6

- Blades permanently etched with its size for long term use

CONTENTS (T3525 413): Imperial blades, sizes: 2, 3, 4, 5, 6, 8, 10, 12, 15, 20, 25, 30 & 35 thousandths of an inch.

CONTENTS (T3525M 413): Metric blades, sizes: 0.05, 0.10, 0.15, 0.20, 0.25, 0.30, 0.40, 0.50, 0.60, 0.70, 0.80, 0.90 & 1.00mm.



### Feeler gauges

Item Number	Length	Scale	Quantity
T3525 413	100mm 4"	imperial	3
T3525M 413	100mm 4"	metric	3

- Brass scale, black lacquered body, tinned hook & ring for corrosion resistance
- Calibrated in 1lb/0.5kg divisions

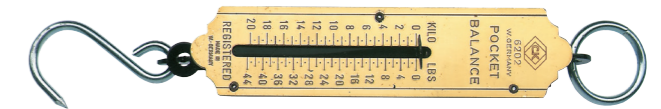

### Pocket balances

Item Number	Weight	Quantity
T6202 025	12.5kg 25lb	12
T6202 032	15kg 32lb	12
T6202 044	20kg 44lb	12
T6202 050	23kg 50lb	6
T6202 066	30kg 66lb	6
T6202 088	40kg 88lb	6
T6202 112	50kg 112lb	6

**WOOD SAWS**

HOLZSÄGEN  
SCIES À BOIS  
SIERRAS PARA MADERA

88-89

**HACKSAWS**

METALLSÄGEN  
SCIES À MÉTAUX  
ARCOS DE SIERRA

89-90

**PLASTERBOARD SAW**

GIPSKARTONSÄGE  
SCIE À GUICHET (POUR LE PLÂTRE)  
SIERRA PARA YESO

90

**TRIMMING KNIVES**

TEPPICHMESSER  
CUTTERS  
CUCHILLOS DE RECORTE

91-93

**WOOD CHISELS**

STECHBEITEL  
CISEAUX À BOIS  
CINCELES PARA MADERA

93

# SAWING & CUTTING

SÄGEN & SCHNEIDEN  
SCIAGE ET DÉCOUPE  
ASERRADO Y CORTADO



# SABRETOOTH

## HIGH PERFORMANCE WOOD SAWS

### HOCHLEISTUNGS HOLZSÄGEN

### SCIÉS A BOIS DE HAUTE PERFORMANCE

### MADERA DE ALTO RENDIMIENTO SIERRAS



#### 1 Triple edge, precision ground teeth specially designed to offer an easy start & outstanding cutting performance on both the push & pull stroke

Dreifachschneidende präzisionsgeschliffene Zähne, speziell entwickelt für leichtes Ansägen und überragende Sägeleistung sowohl beim Stoß- als auch beim Zughub

Dents à triple biseau à rectification de précision spécialement conçues pour offrir un départ aisé et de remarquables performances de coupe, à la traction comme à la poussée

Dientes de sierra afilados de alta precisión con triple borde especialmente diseñados para ofrecer un rendimiento de corte inicial fácil y excelente en el efecto de empuje y tracción

#### 2 Induction hardened teeth for longer lasting sharpness

Induktionsgehärtete Zähne für lang anhaltende Schärfe

Dents trempées par induction pour un affûtage qui dure plus longtemps

Dientes de sierra templados por inducción para proporcionar unafilado de mayor duración

#### 3 Rigid 1mm special alloy steel blade prevents whip & snagging

Robustes 1-mm-Sägeblatt aus spezieller Stahllegierung, die Durchbiegen und Blockieren verhindert

La lame rigide en acier allié spécial de 1 mm prévient le fouettement et les coincements

La hoja rígida de acero de aleación especial de 1 mm evita la torsión y el atascamiento de la sierra

#### 4 Ergonomic two component cushion grip handle with finger index for superior comfort & control

Ergonomisch gepolsterter Handgriff aus zwei Komponenten mit Fingerreihe für überragenden Komfort und bessere Handhabung

Poignée rembourrée bicomposant ergonomique avec position d'appui pour l'index, pour un excellent confort et une meilleure maîtrise de l'outil

Mango ergonómico con mango de dos componentes de agarre acolchado para el dedo índice para máxima comodidad y control



## OUT PERFORMS THE BEST\*

### DEN BESTEN ÜBERLEGEN\*

### LES MEILLEURS RÉSULTATS\*

### DE MAYOR RENDIMIENTO\*

1 BLOCK 100 BLOCKS  
1 BLOCK 100 BLÖCKE  
1 BLOC 100 BLOCS  
1 BLOQUE 100 BLOQUES

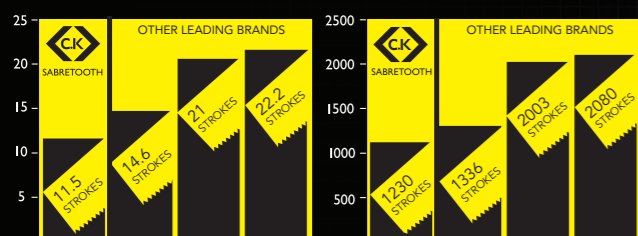

# SABRETOOTH



\*First fix saw tested against UK's market leading saws in independent CATRA tests.

\*Testsieger gegen marktführende Sägen in Großbritannien im unabhängigen CATRA-Test

\*Scie premier passage testée par rapport aux sciés dominant le marché britannique dans le cadre d'essais réalisés par l'organisme indépendant CATRA.

\*La primera opción en sierras, comparadas con las sierras líderes en el mercado del Reino Unido mediante la realización de pruebas independientes CATRA.

## WOOD SAWS



### Sabretooth wood saws

Item Number	Length	Teeth	Quantity
481001	22"	7tpi / 8ppi first fix	10
481002	22"	11tpi / 12ppi second fix	10

CONTENTS: 10 x Sabretooth wood saws.



### Sabretooth wood saws display

Item Number	Length	Teeth	Quantity
581001	22"	7tpi / 8ppi first fix	1
581002	22"	11tpi / 12ppi second fix	1

- Nickel plated flat steel frame for strength & corrosion protection
- 115mm throat for deep cuts
- 360° adjustable blade for intricate cutting

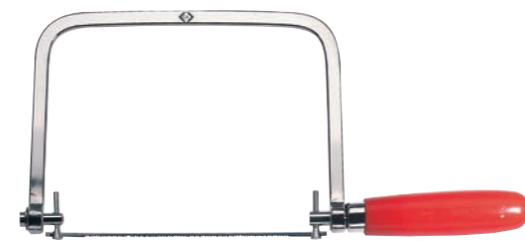

### Coping saw

Item Number	Length	Quantity
T0828	162mm 6 1/2"	3

### Coping saw blades - Pack of 10

Item Number	Length	Quantity
T0829	162mm 6 1/2"	10

## HACKSAWS

- Heavy duty premium quality hacksaw with rubber grips for comfort & control
- Quick release blade change mechanism for convenience
- High leverage blade tensioning system for straighter cuts
- Spare blade storage in back frame for convenience
- 45 & 90° blade positions



### Hacksaw - Quick change

Item Number	Length	Teeth	Quantity
T0814	300mm 12"	24	3

- Heavy duty, box section steel frame with aluminium handle for strength & durability
- High leverage blade tensioning system for straighter cuts
- Spare blade storage in back frame for convenience
- 45 & 90° blade positions



### Hacksaw - Heavy duty

Item Number	Length	Teeth	Quantity
T0905	300mm 12"	24	3

- Box section steel frame with aluminium handle - tough & lightweight
- Spare blade storage in back frame for convenience
- 90° blade positions

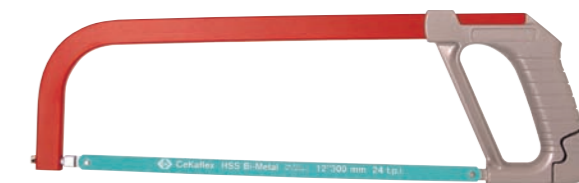

### Hacksaw

Item Number	Length	Teeth	Quantity
T0903 12	300mm 12"	24	3

- Shatterproof HSS Bi-metal construction



### Hacksaw blades

Item Number	Length	tpi	i	Box
T0931R 12	300mm 12"	24	x 3	12
T0932R 12	300mm 12"	18	x 1	50
T0933R 12	300mm 12"	24	x 1	50
T0934R 12	300mm 12"	32	x 1	50

CONTENTS: 18 x hacksaw blades, sizes: 18, 24 & 32 tpi.



### Hacksaw blade display

Item Number	i	Box
T0930RBOM	Stock and stand	1

- Cast aluminium frame for strength
- Broad handle for comfort
- Adjustable blade for angled cutting
- Special screw tensioner for fast & simple blade fitting



### Mini hacksaw

Item Number	Length	Box
T0836A	150mm 6"	6

- Cast aluminium frame for strength
- Broad handle for comfort
- Adjustable blade for angled cutting
- Special screw tensioner for fast & simple blade fitting
- Supplied with lightweight 3 angle mitre box



### Mini hacksaw & mitre box

Item Number	Length	Box
T0837	300mm 12"	5

- Non protruding blade fixing for safety



### Junior hacksaw

Item Number	Length	Box
T0834	150mm 6"	6



### Junior hacksaw blades

Item Number	Length	i	Box
T0835	150mm 6"	x 10	10

## PLASTERBOARD SAWS

- Induction hardened coarse ground cutting teeth & pointed blade for fast cutting of holes in plasterboard for sockets & conduits (Also known as a dry wall saw)



### Plasterboard saw

Item Number	Length	Box
T0831	150mm 6"	10

## TRIMMING KNIVES TEPPICHMESSER CUTTERS CUCHILLOS DE RECORTE



### 1 Robust, die cast aluminium housing - strong & lightweight

Robustes Aluminiumgussgehäuse - stabil und leicht  
Boîtier robuste en aluminium moulé sous pression - solide et léger  
Con carcasa de aluminio fundido, robusto, resistente y de peso ligero

### 2 Safety interlocking design to prevent the blade slipping through the body joint

Sicherheitsverriegelung, um das Zurückgleiten der Klinge in das Gehäuse zu vermeiden  
Emboîtement de sûreté pour prévenir tout glissement de la lame au niveau du joint du corps de l'outil  
Junta entrelazada de seguridad para evitar que la hoja se escurra por la junta del cuerpo

### 3 Ergonomically designed, soft grip handle for increased comfort & control

Ergonomisch gestalteter weicher Handgriff für erhöhten Komfort und bessere Handhabung  
Poignée de conception ergonomique à revêtement souple pour un confort accru et une meilleure maîtrise de l'outil  
Ergonómicos, con mango de agarre suave para una mayor comodidad y control

### 4 Magnetic blade retainer & captive body screw for quick & easy blade changes

Magnetischer Klingenhalter und nicht verlierbarer Schraube am Messerkörper für schnellen und einfachen Klingenswechsel  
Porte-lame magnétique et vis de corps captive pour des changements de lame rapides et faciles  
Retén de la cuchilla magnético y tornillo de sujeción del cuerpo para un cambio de las cuchillas fácil y rápido

### 5 Retractable blade for safe storage

Einziehbare Klinge für sichere Aufbewahrung  
Lame rétractable pour un rangement sûr  
Cuchilla retráctil para un almacenamiento seguro

### 6 String/wire cutting notch for convenience

Schnur/Drahtschneidenute zur vorteilhaften Anwendung  
Encoche coupe-ficelles et coupe-fils pour le confort d'utilisation  
Incluye una muesca para cortar cuerda y alambre

### 7 Internal 5 blade storage compartment

Internes Aufbewahrungsfach für 5 Klinsen  
Compartment de rangement interne pour 5 lames  
Compartimento de almacenamiento interno para 5 cuchillas



## TRIMMING KNIVES

- Fully featured trimming knife - see previous page for details



Soft grip trimming knife - Retractable

Item Number	
T0957-1	6

- Ergonomically designed, soft grip handle for increased comfort & control
- Robust, die cast aluminium housing both strong and lightweight
- Safety interlocking joint to prevent the blade slipping through the body joint
- Magnetic blade retainer & captive body screw for quick & easy blade changes
- Internal 5 blade storage compartment



Soft grip trimming knife - Non retractable

Item Number	
T0957-2	6

- Auto retracting blade for safety in use & storage
- Robust, die cast aluminium housing both strong and lightweight
- Safety interlocking joint to prevent the blade slipping through the body joint



Trimming knife - Auto retracting

Item Number	
T0969	6

- Robust, die cast aluminium housing both strong and lightweight
- Safety interlocking joint to prevent the blade slipping through the body joint
- Magnetic blade retainer & captive body screw for quick & easy blade changes
- Retractable blade for safe storage
- String/wire cutting notch for convenience
- Internal 5 blade storage compartment



Trimming knife - Retractable

Item Number	
T0956-1	6

- Robust, die cast aluminium housing both strong and lightweight
- Safety interlocking joint to prevent the blade slipping through the body joint
- Magnetic blade retainer & captive body screw for quick & easy blade changes
- Internal 5 blade storage compartment



Trimming knife - Non retractable

Item Number	
T0956-2	6

- Heavy duty blades supplied in a spring loaded blade dispenser for safety & convenient storage



Spare blades - Standard

Item Number		
T0959-10	x 10	12
T0959-50	x 50	12
T0959-100	x 100	12

- Heavy duty plastic body with soft grip handle for comfort & control
- Push button blade positioning with locking system for control & safety
- Integrated blade snapper for safe blade segment removal
- Supplied with 4 blades stored in the handle for convenience



Trimming knife - Snap off blade

Item Number	
T0958	12

- Heavy duty blades supplied in a spring loaded blade dispenser for safety & convenient storage



Spare blades - Snap off

Item Number		
T0971-10	x 10	12

## WOOD CHISELS

- Finest chrome vanadium steel, full length hardened & tempered for long life performance
- Shatterproof acetate handle for safety
- Replaceable blade cover for protection & safety



Wood chisels

Item Number		
T1178 025	6mm 1/4"	3
T1178 037	10mm 3/8"	3
T1178 050	13mm 1/2"	3
T1178 062	16mm 5/8"	3
T1178 075	19mm 3/4"	3
T1178 087	22mm 7/8"	3
T1178 100	25mm 1"	3
T1178 125	32mm 1 1/4"	3
T1178 150	38mm 1 1/2"	3

- Supplied with silicone carbide sharpening stone & protective storage case

CONTENTS: 1 x wood chisel, sizes: 6, 13, 19, & 25mm. Sharpening stone.



Wood chisels & sharpening stone set

Item Number		
T1180	5 piece set	3

- Double sided medium/fine silicon carbide sharpening stone, ideal for sharpening chisels, scissors, shears, etc.



Sharpening stone

Item Number		
T1126	200 x 50mm	1

CONTENTS: 3 x wood chisels, sizes: 6, 10, 13, 16, 19, 22, 25, 32 & 38mm. Sharpening stone.



Wood chisel display

Item Number		
T1179LS	Stock and stand	1



### SURE DRIVE SOCKETS & ACCESSORIES

STECKSCHLÜSSEL UND ZUBEHÖR  
DOUILLES ET ACCESSOIRES  
VASOS Y ACCESORIOS

96-98

### SURE DRIVE SOCKET SETS

SURE DRIVE STECKSCHLÜSSELSÄTZE  
JEUX DE DOUILLES SURE DRIVE  
SURE DRIVE SETS DE VASOS

99

### SPANNERS

SCHRAUBENSCHLÜSSEL  
CLÉS  
LLAVES FIJAS

100-101

### WRENCHES

VERSTELLBARE SCHRAUBENSCHLÜSSEL  
CLÉS  
LLAVES

101-102

### HEXAGON KEYS

INNENSECHSKANTSCHLÜSSEL  
CLÉS MÂLES À SIX PANS  
LLAVES HEXAGONALES

102-103

# SOCKETS, SPANNERS & WRENCHES

STECKSCHLÜSSEL & SCHRAUBENSCHLÜSSEL  
DOUILLES ET CLÉS  
CASQUILLOS, LLAVES DE TUERCAS Y LLAVES INGLESAS





# SURE-DRIVE ADVANCED NUT DRIVING SYSTEM

SCHRAUBEN- UND MUTTERSCHONENDES ANTRIEBSSYSTEM  
SYSTEME DE VISSAGE D'ECROU AVANCE "ANTI-ARRONDISSEMENT"  
SISTEMA AVANZADO DE APRIETE Y PROTECCIÓN DE TUERCA



## RATCHET HANDLE

KNARREN  
CLÉ À CLIQUET  
LLAVES CARRACA

### 1 Heavy duty chrome vanadium construction for superior strength & durability

Hoch belastbare Chrom-Vanadiumstahl-Ausführung für überragende Festigkeit und Dauerhaftigkeit  
Réalisation robuste en acier au chrome-vanadium, garantissant une résistance et une durabilité excellentes  
Construcción en cromo-vanadio de gran resistencia para una superior durabilidad

### 2 Reversible, 45 tooth ratchet mechanism for a finer working arc (8° arc)

Umkehrbarer 45-Zähne-Ratschenmechanismus für einen feineren Betätigungswinkel (8°)  
Mécanisme de cliquet réversible à 45 dents pour un arc de travail plus fin (8°)  
Mecanismo de trinquete reversible de 45 dientes para un arco de trabajo más fino (arco de 8°)

### 3 Ball bearing locking system with push button release mechanism for quick inter-change of sockets

Kugelgelagertes Arretierungssystem mit Freigabe durch Drucktaste für schnelles Auswechseln der Steckschlüssel  
Système de verrouillage à roulement à billes avec mécanisme de déblocage par bouton-poussoir pour un changement de douille rapide  
Sistema de bloqueo de cojinete de bolas con un mecanismo de liberación mediante pulsador para el intercambio rápido de los vasos

### 4 Dual component, non slip grip for added comfort & control

Nicht rutschender Zweikomponentengriff für zusätzlichen Komfort und bessere Handhabung  
Poignée antidérapante bicomposant pour plus de confort et une meilleure maîtrise de l'outil  
Mango de dos componentes, agarre antideslizante para mayor comodidad y control

## SOCKETS

STECKSCHLÜSSEL  
DOUILLES  
VASOS

### 5 Forged Chrome Vanadium steel for superior strength & durability

Geschmiedeter Chrom-Vanadiumstahl für überragende Festigkeit und Dauerhaftigkeit  
Acier au chrome-vanadium forgé, garantissant une résistance et une durabilité excellentes  
Acero de cromo-vanadio para una resistencia y una durabilidad superiores

### 6 Non slip, satin chrome plated for resistance to rust & peeling

Nicht rutschend, matt verchromt für den Schutz gegen Rost und Abblättern  
Finition chromée satinée antidérapante pour la protection antirouille et la résistance à l'écaillage.  
Plateado al cromo satinado antideslizante, para resistencia al óxido y evitar el descascarillarse

### 7 C.K. 'Sure-drive' system applies torque to the flat of the nut rather than the corners to avoid rounding off

C.K. 'Sure-drive'-System, welches das Drehmoment eher auf die Fläche der Mutter als auf die Ecken überträgt, um Abrunden zu vermeiden  
Le système 'Sure-drive' de C.K applique le couple sur le pan de l'écrou plutôt que sur les arêtes, évitant ainsi de les arrondir (usure)  
El sistema C.K. 'Sure-drive' aplica par a las caras de la tuerca y no a los ángulos para evitar el redondeado de éstos



## SURE-DRIVE SOCKETS & ACCESSORIES



### Sockets - 1/2" drive metric

Item Number	Size	Quantity
T4690M 10	10mm	5
T4690M 11	11mm	5
T4690M 12	12mm	5
T4690M 13	13mm	5
T4690M 14	14mm	5
T4690M 15	15mm	5
T4690M 16	16mm	5
T4690M 17	17mm	5
T4690M 18	18mm	5
T4690M 19	19mm	5
T4690M 20	20mm	5
T4690M 21	21mm	5
T4690M 22	22mm	5
T4690M 23	23mm	5
T4690M 24	24mm	5
T4690M 27	27mm	5
T4690M 30	30mm	5
T4690M 32	32mm	5

- Heavy duty chrome vanadium construction for superior strength and durability
- Micrometer sleeve for accurate torque setting
- Individually calibrated and supplied with a certificate of calibration
- Supplied in a protective storage case complete with 120mm extension drive & 3/8" square drive adapter



### Torque wrench - 1/2" drive

DIN 3122

Item Number	Size	Capacity	Quantity
T4463	600mm 18"	42-210Nm / 30-154lb-ft	12

CONTENTS: 3 x sockets, size: 10, 11, 12, 13, 14, 15, 16, 17, 18, 19, 20 & 21. 2 x sockets, size: 22, 23, 24, 27, 30 & 32mm.



### Sockets display stand

Item Number	Description	Quantity
T4644RBOM	stock and stand	1



### Ratchet handle - 1/2" drive 45 teeth

Item Number	Quantity
T4691	5

- Heavy duty chrome vanadium construction for superior strength and durability
- Dual component, non slip grip for added comfort & control



### Flexible handle - 1/2" drive

Item Number	Size	Quantity
T4692	430mm 17"	5

- Reversible, 24 tooth ratchet mechanism for high torque applications
- Heavy duty chrome vanadium construction for superior strength & durability
- Ball bearing locking system with push button release mechanism for quick inter-change of sockets



**Ratchet handle -**  
1/2" drive 24 teeth

Item Number	
T4603	3

**Ratchet handle -**  
1/2" drive 24 teeth - repair kit

Item Number	
T4603 1	1

- Heavy duty chrome vanadium construction for superior strength & durability



**Sliding T-handle -**  
1/2" drive

Item Number	
T4695	250mm 10" 5

- Heavy duty chrome vanadium construction for superior strength & durability



**Long extension -**  
1/2" drive

Item Number	
T4693	250mm 10" 5

- Heavy duty chrome vanadium construction for superior strength & durability



**Short extension -**  
1/2" drive

Item Number	
T4694	125mm 5" 5

- Heavy duty chrome vanadium construction for superior strength & durability



**Universal joint -**  
1/2" drive

Item Number	
T4696	5

CONTENTS: 3 x ratchet handle. 3 x sliding t-handle. 3 x flexible handle. 3 x long extension. 3 x short extension. 3 x universal joint.



**Socket accessory bar -**  
1/2" drive

Item Number	
T4645RBOM	stock and stand 1

**SURE-DRIVE SOCKET SETS**

CONTENTS: 45 tooth ratchet handle. 1 x socket, sizes: 10, 11, 12, 13, 14, 15, 16, 17, 18, 19, 22, 24, 27, 30 & 32mm. 1 x long reach socket, sizes: 16 & 21mm. Long extension. Short extension. Universal joint. 3/8" drive adaptor/t-handle adaptor.



**Socket set - 22 Piece**  
1/2" drive metric

Item Number	
T4657	1

CONTENTS: 45 tooth ratchet handle. 1 x socket, sizes: 6, 7, 8, 9, 10, 11, 12, 13, 14, 15, 16, 17, 18, 19, 20, 21, 22 & 24mm. Long extension. Short extension. Universal joint. 1/2" drive adaptor/t-handle adaptor.

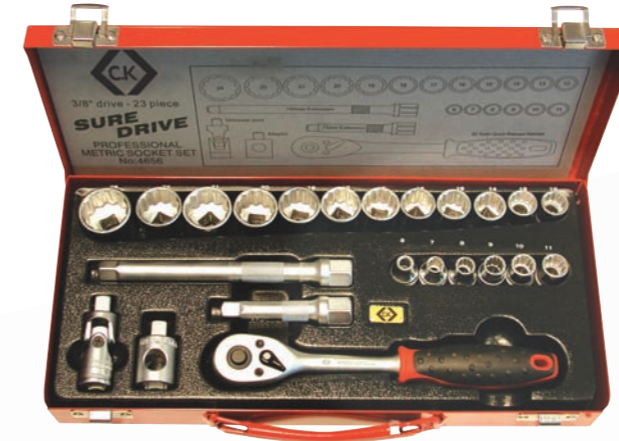

**Socket set - 23 Piece**  
3/8" drive metric

Item Number	
T4656	2

CONTENTS: 45 tooth ratchet handle. 1 x socket, sizes: 4, 4.5, 5, 5.5, 6, 7, 8, 9, 10, 11, 12, 13 & 14mm. 1 x hexagon socket bit, sizes: 3, 4, 5 & 6mm. 1 x tamperproof TX socket bit, sizes: 8, 10, 15, 20, 25, 27, 30 & 40. 1 x socket bit, slotted, sizes: 4, 5.5 & 7mm; PZ, sizes: 1, 2 & 3; PH, sizes: 1, 2 & 3. Short extension. 1/4" drive handle. Universal joint. Hex to 1/4" drive adaptor.



**Socket set - 39 Piece**  
1/4" drive metric

Item Number	
T4655	3



## SPANNERS

- Drop forged chrome vanadium steel, hardened & tempered for strength & durability
- Heavy duty chrome plated for corrosion resistance
- 12° offset bi-hex ring for access



### Combination spanners - Metric

DIN 3113

Item Number	Length	Width	Material	Quantity
T4343M 06	100mm	6mm	loose	10
T4343M 06H			on hanger	6
T4343M 07	110mm	7mm	loose	10
T4343M 07H			on hanger	6
T4343M 08	120mm	8mm	loose	10
T4343M 08H			on hanger	6
T4343M 09	130mm	9mm	loose	10
T4343M 09H			on hanger	6
T4343M 10	140mm	10mm	loose	10
T4343M 10H			on hanger	3
T4343M 11	150mm	11mm	loose	10
T4343M 11H			on hanger	3
T4343M 12	160mm	12mm	loose	10
T4343M 12H			on hanger	3
T4343M 13	170mm	13mm	loose	10
T4343M 13H			on hanger	3
T4343M 14	180mm	14mm	loose	10
T4343M 14H			on hanger	6
T4343M 15	190mm	15mm	loose	10
T4343M 15H			on hanger	6
T4343M 16	200mm	16mm	loose	10
T4343M 16H			on hanger	6
T4343M 17	210mm	17mm	loose	10
T4343M 17H			on hanger	3
T4343M 18	220mm	18mm	loose	10
T4343M 18H			on hanger	1
T4343M 19	230mm	19mm	loose	10
T4343M 19H			on hanger	1
T4343M 20	240mm	20mm	loose	5
T4343M 20H			on hanger	1
T4343M 21	250mm	21mm	loose	5
T4343M 21H			on hanger	1
T4343M 22	260mm	22mm	loose	5
T4343M 22H			on hanger	1
T4343M 24	280mm	24mm	loose	5
T4343M 24H			on hanger	1

Continued in the next column

T4343M 27	310mm	27mm	loose	5
T4343M 27H			on hanger	1
T4343M 30	340mm	30mm	loose	5
T4343M 30H			on hanger	1
T4343M 32	360mm	32mm	loose	5
T4343M 32H			on hanger	1

- Supplied in a wall mounting rack for convenient storage

CONTENTS: 1 x combination spanner, sizes: 8, 9, 10, 11, 12, 13, 14, 15, 17, 19, 21 & 22mm.



### Combination spanners set - 12 Piece metric

DIN 3113

Item Number	Quantity
T4343M/12ST	1

- Supplied in a wall mounting rack for convenient storage

CONTENTS: 1 x combination spanner, sizes: 8, 9, 10, 11, 12, 13, 14, 15, 17, & 19mm.



### Combination spanners set - 10 Piece metric

DIN 3113

Item Number	Quantity
T4343M/10ST	3

CONTENTS: 2 x combination spanners, sizes: 6, 7, 8, 9, 10, 11, 12, 13, 14, 15, 16, 17, 18, 19, 20, 21, 22 & 24mm.  
1 x combination spanners, sizes: 27, 30 & 32mm.



### Combination spanner display

Item Number	Description	Quantity
T4343MRBOM	stock and stand	1

- Drop forged chrome vanadium steel, hardened & tempered for strength & durability
- Colour coded for quick selection of the correct size
- Innovative ratchet action style jaw for use in tight places
- 12° offset bi-hex ring for access
- Supplied in a wall mounting rack for convenient storage

CONTENTS: 1 x combination spanner, sizes: 10, 12, 13, 14, 15 & 17mm



### Speed spanners set - 6 Piece metric

Item Number	Quantity
T4345/6ST	5

## WRENCHES

- Sure-drive jaws which apply torque to the flat of the nut rather than the corners to avoid rounding off
- Extra capacity jaws - up to 18% wider than standard patterns



### Adjustable wrench - Sure drive

Item Number	Length	Width	Quantity
T4365 150	150mm 6"	24mm	3
T4365 200	200mm 8"	29mm	3
T4365 250	250mm 10"	33mm	3
T4365 300	300mm 12"	38mm	3

- Extra capacity jaws - up to 26% wider than standard patterns



### Adjustable wrenches - Wide jaw

Item Number	Length	Width	Quantity
T4366 150	150mm 6"	24mm	6
T4366 200	200mm 8"	29mm	6
T4366 250	250mm 10"	33mm	6
T4366 300	300mm 12"	38mm	6
T4366 375	375mm 15"	51mm	5
T4366 450	450mm 18"	60mm	5

- Chrome plated for corrosion resistance



### Adjustable wrenches - Standard

Item Number	Length	Width	Quantity
T4368 150	150mm 6"	19mm	6
T4368 200	200mm 8"	24mm	6
T4368 250	250mm 10"	29mm	6
T4368 300	300mm 12"	34mm	6

- Concave jaws ideal for gripping round profile
- Integral wire cutting blades for convenience



**Self grip wrenches - Concave jaws**

Item Number	Length	Width	Depth
T3630 10	250mm 10"	50mm	5

- Combination straight & curved jaws ideal for gripping round, flat & square profile



**Self grip wrenches - Straight/curved jaws**

Item Number	Length	Width	Depth
T3638 07	180mm 7"	25mm	6
T3638 10	250mm 10"	35mm	6

- Flat jaws ideal for gripping flat profile



**Self grip wrenches - Straight jaws**

Item Number	Length	Width	Depth
T3641	250mm 10"	40mm	5

- High quality drop forged steel construction with hardened & tempered jaws for strength & durability
- Patented head design for high torque performance



**Stillson wrenches**

Item Number	Length	Width	Depth
T3735 300	300mm 12"	38mm	8
T3735 350	350mm 14"	55mm	8
T3735 400	450mm 18"	55mm	8
T3735 600	600mm 24"	70mm	8

**HEXAGON KEYS**

- Chrome vanadium steel, hardened & tempered for strength & durability



**Hexagon keys - Metric**

ISO 2936

Item Number	Width	Length	Tip	Count
T4411 007	0.7mm	32mm	6mm	12
T4411 009	0.9mm	32mm	10mm	12
T4411 01	1.0mm	32mm	10mm	12
T4411 012	1.2mm	38mm	10mm	12
T4411 0127	1.27mm	40mm	12mm	12
T4411 015	1.5mm	45mm	14mm	12
T4411 02	2.0mm	50mm	16mm	12
T4411 025	2.5mm	56mm	18mm	12
T4411 03	3.0mm	63mm	20mm	12
T4411 035	3.5mm	67mm	23mm	12
T4411 04	4.0mm	71mm	25mm	12
T4411 045	4.5mm	75mm	26mm	12
T4411 05	5.0mm	80mm	28mm	12
T4411 055	5.5mm	85mm	30mm	12
T4411 06	6.0mm	90mm	32mm	12
T4411 07	7.0mm	95mm	34mm	12
T4411 08	8.0mm	100mm	36mm	12
T4411 09	9.0mm	105mm	38mm	12
T4411 10	10.0mm	112mm	40mm	12
T4411 11	11.0mm	118mm	43mm	12
T4411 12	12.0mm	125mm	45mm	6
T4411 13	13.0mm	133mm	50mm	6
T4411 14	14.0mm	140mm	56mm	3
T4411 15	15.0mm	147mm	58mm	3
T4411 16	16.0mm	154mm	60mm	3
T4411 17	17.0mm	160mm	63mm	3
T4411 18	18.0mm	170mm	65mm	3
T4411 19	19.0mm	180mm	70mm	3
T4411 20	20.0mm	187mm	73mm	3
T4411 22	22.0mm	200mm	80mm	3

- Supplied in a heavy duty nickel plated steel clip holder for convenience



**Hexagon key folding sets - 7 Piece**

Item Number	Key Sizes	Count
T4404A	Metric 2.5, 3, 4, 5, 6, 7, 8mm	6
T4405A	Imperial AF 3/32, 5/32, 3/16, 3/8, 1/4, 5/16, 1/8"	6

- Supplied in a clip holder for convenience



**TX tamperproof key folding set - 8 Piece**

Item Number	Key Sizes	Count
T4407	T06, T07, T08, T09, T10, T15, T20, T25	12

- Ball ended for use at an angle of up to 25° where access is restricted
- Supplied in a storage holder for convenience



**Hexagon key clip set - 10 Piece ball end**

Item Number	Key Sizes	Count
T4443M	Metric 1.5, 2, 2.5, 3, 4, 5, 6, 7, 8, 10mm	6

- Ball ended for use at an angle of up to 25° where access is restricted
- Supplied in a storage holder for convenience



**Hexagon key clip set - 9 Piece ball end**

Item Number	Key Sizes	Count
T4444I	Imperial AF 5/64, 3/32, 1/8, 5/32, 3/16, 7/32, 1/4, 5/16, 3/8"	6

- Supplied on a key ring for convenience



**Hexagon key ring set - 8 Piece**

ISO 2936

Item Number	Key Sizes	Count
T4414	Imperial AF 1/16, 5/64, 3/32, 1/8, 5/32, 3/16, 7/32, 1/4"	6
T4417	Metric 1.5, 2, 2.5, 3, 4, 5, 6, 7mm	6

- Supplied on a key ring for convenience

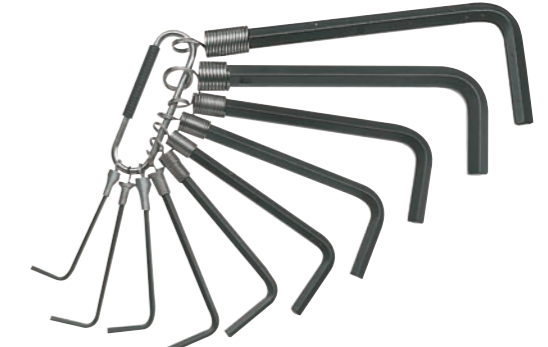

**Hexagon key ring set - 10 Piece**

ISO 2936

Item Number	Key Sizes	Count
T4415	Imperial AF 1/16, 5/64, 3/32, 1/8, 5/32, 3/16, 7/32, 1/4, 5/16, 3/8"	6
T4416	Metric 1.5, 2, 2.5, 3, 4, 5, 6, 7, 8, 10mm	6

**FILES**

FEILEN  
LIMES  
LIMAS

106-107

**WARDING & NEEDLE FILES**

SCHLÜSSEL- & NADELFEILEN  
LIMES DE SERRURIER ET À AIGUILLE  
LIMAS DE PALETONES Y DE AGUJAS

108-109

**HAMMERS**

HÄMMER  
MARTEAUX  
MARTILLOS

109-110

**PUNCHES**

KÖRNER UND DURCHSCHLÄGE  
POINTEAUX  
PUNZONES

110

**SNIPS**

BLECHSCHEREN  
CISEAUX ET CISAILLES  
TIJERAS DE CHAPA

110

**COMPOUND ACTION SNIPS**

KOMBI BLECHSCHEREN  
CISAILLES À ACTION COMPOSÉE  
TIJERAS DE CHAPA COMPUESTAS

110

**STUD EXTRACTORS**

STEBBOLZENZIEHER  
EXTRACTEURS DE GOUJONS  
SACAESPIGAS

111

**TAP & DIE SET**

GEWINDESCHNEIDEISEN SATZ  
JEU DE TARAUDS ET FILIÈRES  
CONJUNTO DE TERRAJAS DE ROSCAS

111

**WIRE BRUSH**

DRAHTBÜRSTE  
BROSSE MÉTALLIQUE  
CEPILLO DE ALAMBRE

111

# ENGINEER'S TOOLS

MECHANIKERWERKZEUGE  
OUTILS MECHANIQUE  
HERRAMIENTAS DE MECÁNICO



FILES

FILES



1 Manufactured from special file steel, precision cut & hardened for outstanding performance and durability

2 Ergonomic, soft grip handle for superior comfort & control

3 Specially designed solid inner core for a safe & secure handle to tang bond



- One safe edge



Engineer's file - Flat bastard cut

Item Number	Length	Icon	Quantity
T0080B 10	250mm 10"		3

- One safe edge



Engineer's files - Flat second cut

Item Number	Length	Icon	Quantity
T0080 6	150mm 6"		3
T0080 8	200mm 8"		3
T0080 10	250mm 10"		3

- One safe edge



Engineer's files - Flat smooth cut

Item Number	Length	Icon	Quantity
T0080S 6	150mm 6"		3
T0080S 8	200mm 8"		3

- Tapered towards the point



Engineer's files - Half round second cut

Item Number	Length	Icon	Quantity
T0082 6	150mm 6"		3
T0082 8	200mm 8"		3
T0082 10	250mm 10"		3

- Tapered towards the point



Engineer's files - Round second cut

Item Number	Length	Icon	Quantity
T0083 6	150mm 6"		3
T0083 8	200mm 8"		3
T0083 10	250mm 10"		3

- 1 side bastard rasp
- 1 side bastard cut

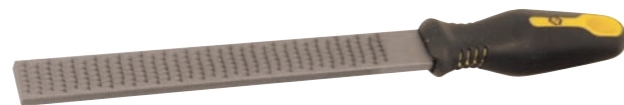

Combined file & rasp

Item Number	Length	Icon	Quantity
T0106 06	150mm 6"		3
T0106 08	200mm 8"		3

- Tapered towards the point



Wood rasp

Item Number	Length	Icon	Quantity
T0107 06	150mm 6"		3
T0107 08	200mm 8"		3

- Second cut



Chain saw files

Item Number	Length	Ø	Icon	Quantity
T0079 1	150mm 6"	4mm 5/32"		3
T0079 2	200mm 8"	5mm 3/16"		3
T0079 3	250mm 10"	5.5mm 7/32"		3

- Tapered towards the point



Saw file - Standard

Item Number	Length	Icon	Quantity
T0074 6	150mm 6"		3

- Tapered towards the point



Saw file - Slim

Item Number	Length	Icon	Quantity
T0073 6	150mm 6"		3

- Tapered towards the point



Saw file - Extra slim

Item Number	Length	Icon	Quantity
T0072 5	125mm 5"		3

- Flat profile
- Single cut



Mill saw file

Item Number	Length	Icon	Quantity
T0075 10	250mm 10"		3

CONTENTS: 3 x engineer's files, flat second cut, sizes: 150 & 200mm. 3 x engineer's files, flat smooth cut, sizes: 150 & 200mm. 3 x engineer's files, half round, sizes: 150 & 200mm. 3 x engineer's files, round, sizes: 150 & 200mm. 3 x file/rasps, sizes: 150 & 200mm. 3 x saw files, extra slim, size: 125mm. 3 x saw files, slim, size: 150mm. 3 x saw files, standard, size: 150mm. 3 x mill saw files, size: 250mm. 3 x chain saw files, sizes: 150 & 200mm.

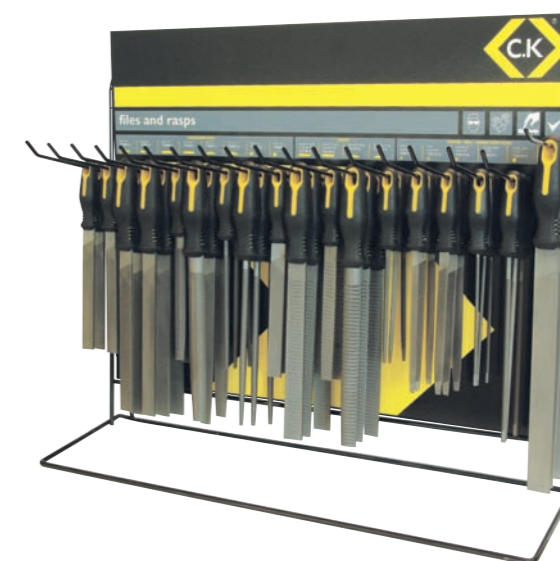

File display

Item Number	Icon	Quantity
T0098LS/1		1

WARDING & NEEDLE FILES



Warding file - Flat second cut, square

Item Number	100mm 4"	i	6
T0120 1	100mm 4"		6



Warding file - Flat second cut, tapered

Item Number	100mm 4"	i	6
T0120 2	100mm 4"		6



Warding file - Half round second cut

Item Number	100mm 4"	i	6
T0120 3	100mm 4"		6



Warding file - Round second cut

Item Number	100mm 4"	i	6
T0120 4	100mm 4"		6



Warding file - Square second cut

Item Number	100mm 4"	i	6
T0120 5	100mm 4"		6



Warding file - Triangular second cut

Item Number	100mm 4"	i	6
T0120 6	100mm 4"		6



Warding file set - 6 Piece

Item Number	100mm 4"	i	3
T0120P	100mm 4"		3



Warding file set - 4 Piece

Item Number	100mm 4"	i	3
T0119	100mm 4"		3



Needle file set - 6 Piece

Item Number	i	3
T0124P		3

- Brass chuck securely grips the needle file shaft for safe use



Needle file handle

Item Number	95mm 3 3/4"	6
T0071	95mm 3 3/4"	6

HAMMERS

- Drop forged high carbon steel head - hardened & tempered for superior strength and durability
- Black lacquered to protect against corrosion
- Tough hickory shaft for durability
- Ball pein for setting rivets



Ball pein hammers

Item Number		3
T4208H 08	227g 1/2 lb	3
T4208H 16	454g 1 lb	3
T4208H 24	682g 1 1/2 lb	3
T4208H 32	908g 2 lb	3

- Drop forged high carbon steel head - hardened & tempered for superior strength and durability
- Black lacquered to protect against corrosion
- Traditional ash shaft for strength



Engineer's hammer - French pattern

Item Number	300g 10 1/2 oz	12
356002	300g 10 1/2 oz	12

- Drop forged high carbon steel head - hardened & tempered for superior strength and durability
- Black lacquered to protect against corrosion
- Traditional ash shaft for strength



Engineer's hammers - German pattern

DIN 1041

Item Number		12
T4227A 0100	100g 3 1/2 oz	12
T4227A 0200	200g 7 oz	12
T4227A 0300	300g 10 1/2 oz	12
T4227A 0500	500g 17 1/2 oz	12
T4227A 1000	1000g 35oz	12

PUNCHES

- Hardened carbon steel with gun metal finish for protection
- Knurled shaft for grip



Centre punch - Round 10mm

Item Number	100mm 4"	12
T3307P	100mm 4"	12

- High quality chrome vanadium steel hardened for durability



Centre punch - Octagonal 10mm

Item Number	150mm 6"	6
T3319	150mm 6"	6

- High quality chrome vanadium steel hardened for durability



Centre punch - Octagonal 12mm

Item Number	120mm 4 3/4"	3
T3326	120mm 4 3/4"	3

- High quality chrome molybdenum steel hardened for durability



### Parallel pin punches

DIN 6450

Item Number	Length	Tip Diameter	Quantity
T3328 05	150mm 6"	2mm 5/64"	3
T3328 06	150mm 6"	2.5mm 3/32"	3
T3328 08	150mm 6"	3mm 1/8"	3
T3328 10	150mm 6"	4mm 5/32"	3
T3328 12	150mm 6"	5mm 3/16"	3
T3328 14	150mm 6"	5.5mm 7/32"	3
T3328 16	150mm 6"	6mm 1/4"	3
T3328 20	150mm 6"	8mm 5/16"	3
T3328 24	150mm 6"	10mm 3/8"	3



### Parallel pin punch set - 6 Piece

DIN 6450

Item Number	Tip Sizes	Quantity
T3328S	2, 2.5, 3, 4, 5 & 6mm	1

### SNIPS

- Forged alloy steel for strength & durability
- Hardened & tempered jaws for high cutting performance
- Stop pin to prevent finger nipping during use

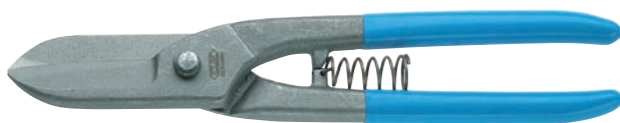

### Tin snips

Item Number	Length	Quantity
T4536 08	200mm 8"	3
T4536 10	250mm 10"	3

- Lightweight multipurpose cutter for paper, card, cloth, thin sheet metal, etc



### Tuff snips

Item Number	Length	Quantity
T4506	180mm 7"	6

### COMPOUND ACTION SNIPS

- Compound action, high leverage design for easy cutting of steel, stainless steel, titanium, etc
- Forged chrome molybdenum steel jaws, hardened and tempered for long term cutting performance
- Ergonomic grips with slip guards for safety



### Compound action snips

Item Number	Length	Direction	Quantity
T4537AS	240mm 10"	straight	3



### Compound action snips

Item Number	Length	Direction	Quantity
T4537AL	240mm 10"	left	3



### Compound action snips

Item Number	Length	Direction	Quantity
T4537AR	240mm 10"	right	3

### STUD EXTRACTORS

- Hardened chrome vanadium steel
- Left hand threaded for extracting broken studs and screws



### Stud extractor set - 5 Piece

Item Number	Quantity
T3062 01	5

- Hardened chrome vanadium steel
- Left hand threaded for extracting broken studs and screws



### Stud extractor set - 6 Piece

Item Number	Quantity
T3062 02	5

### TAP & DIE SETS

- High carbon steel, hardened & tempered for strength and durability
- Precision machined to produce accurate thread forms

CONTENTS: Tap & dies, sizes: 3 x 0.5, 4 x 0.7, 5 x 0.8, 6 x 1.0, 7 x 1.0, 8 x 1.25, 10 x 1.5, 12 x 1.75mm & 1/8" NPT. Tap wrench. Die stock. Screwdriver.

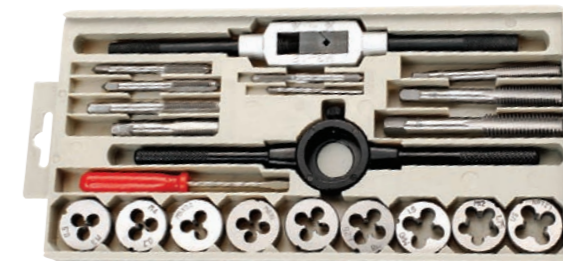

### Tap & die set - 21 Piece metric

Item Number	Quantity
T4032	6

### WIRE BRUSH

- Hardened & tempered steel wire bristles, set in 4 rows for professional results



### Wire brush

Item Number	Rows	Quantity
T6238 4	4 rows	12



**CONCRETE DRILL BITS**

BETONBOHRER  
 FORETS À BÉTON  
 BROCAS PARA HORMIGÓN

114-115

**BRICK DRILL BITS**

STEINBOHRER  
 FORETS À MAÇONNERIE  
 BROCAS PARA LADRILLO

116

**METAL DRILL BITS**

METALLBOHRER  
 FORETS À MÉTAUX  
 BROCAS PARA PERFORACIÓN EN METAL

116-119

**MULTIPURPOSE DRILL BITS**

MEHRZWECKBOHRER  
 FORETS UNIVERSELS  
 BROCAS MULTIFUNCIÓN

119

**FAST4**

FAST4  
 FAST4  
 FAST4

120-121

**WOOD DRILL BITS**

HOLZBOHRER  
 MÈCHES À BOIS  
 BROCAS PARA MADERA

121-123

**HOLESAWS**

LOCHSÄGEN  
 SCIES-CLOCHE  
 PORTAPUNTAS

124-125

**HOLESAW KITS**

LOCHSÄGENSÄTZE  
 JEUX DE SCIES-CLOCHE  
 KITS DE PORTAPUNTAS

126

**SCREWDRIVER BITS - STANDARD**

SCHRAUBENDREHERBITS  
 EMBOUTS DE VISSAGE  
 PUNTAS DE DESTORNILLADOR

127-129

**SCREWDRIVER BIT SETS**

SCHRAUBENDREHERBITSÄTZE  
 JEUX D'EMBOUTS DE VISSAGE  
 CONJUNTOS DE PUNTAS DE DESTORNILLADOR

129-131

**SCREWDRIVER BITS - TIN COATED**

SCHRAUBENDREHERBITS - TIN-BESCHICHTET  
 EMBOUTS DE VISSAGE - REVÊTEMENT TIN  
 PUNTAS DE DESTORNILLADOR - GALVANIZADO

131-133

**SCREWDRIVER BIT HOLDERS**

SCHRAUBENDREHER-BITHALTER  
 PORTE-EMBOUTS DE VISSAGE  
 PORTAPUNTAS DE DESTORNILLADOR

134

**JIGSAW BLADES**

LAUBSÄGEBLÄTTER  
 LAMES DE SCIE SAUTEUSE  
 HOJAS DE SIERRA DE CALAR

134-135

# POWER TOOL ACCESSORIES

ELEKTROWERKZEUGE - ZUBEHÖR  
 ACCESSOIRES POUR OUTILS ÉLECTRIQUES  
 ACCESORIOS PARA HERRAMIENTAS MOTORIZADAS



## CONCRETE DRILL BITS

- Forged steel with tungsten carbide tip for durability
- Optimised design for high performance drilling of concrete & stone

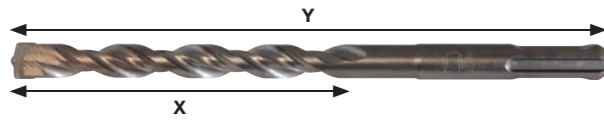

### Concrete drill bits SDS-Plus

Item Number	Ø	X	Y	📦
T3140 0511	5mm	50mm	110mm	6
T3140 0516	5mm	100mm	160mm	6
T3140 05511	5.5mm	50mm	110mm	6
T3140 05516	5.5mm	100mm	160mm	6
T3140 0611	6mm	50mm	110mm	6
T3140 0616	6mm	100mm	160mm	6
T3140 0621	6mm	150mm	210mm	6
T3140 06511	6.5mm	50mm	110mm	6
T3140 06516	6.5mm	100mm	160mm	6
T3140 0711	7mm	50mm	110mm	6
T3140 0716	7mm	100mm	160mm	6
T3140 0811	8mm	50mm	110mm	6
T3140 0816	8mm	100mm	160mm	6
T3140 0821	8mm	150mm	210mm	6
T3140 0826	8mm	200mm	260mm	6
T3140 0845	8mm	400mm	450mm	6
T3140 1016	10mm	100mm	160mm	6
T3140 1021	10mm	150mm	210mm	6
T3140 1026	10mm	200mm	260mm	6
T3140 1045	10mm	400mm	450mm	6
T3140 1215	12mm	100mm	160mm	6
T3140 1221	12mm	150mm	210mm	6
T3140 1225	12mm	200mm	260mm	6
T3140 1245	12mm	400mm	450mm	6
T3140 12100	12mm	950mm	1000mm	6
T3140 1425	14mm	200mm	250mm	6
T3140 1445	14mm	400mm	450mm	6
T3140 1630	16mm	250mm	300mm	6
T3140 1645	16mm	400mm	450mm	6
T3140 16100	16mm	950mm	1000mm	6
T3140 1830	18mm	250mm	300mm	6
T3140 1845	18mm	400mm	450mm	6
T3140 2030	20mm	250mm	300mm	6
T3140 2045	20mm	400mm	450mm	6
T3140 20100	20mm	950mm	1000mm	6
T3140 2545	25mm	400mm	450mm	6
T3140 25100	25mm	950mm	1000mm	6

CONTENTS: 1 x drill bit, sizes: 5 x 110, 6 x 110, 8 x 110, 6 x 150, 8 x 150, 10 x 150 & 12 x 150mm.



### Concrete drill bits SDS-Plus set - 7 Piece

Item Number	📦
T3144	1

CONTENTS: 6 x drill bits, sizes: 5.5 x 110, 5.5 x 160 & 7 x 160mm. 3 x drill bits, sizes: 6 x 110, 6 x 160, 8 x 160 & 10 x 160mm. 2 x drill bits, size: 10 x 210mm.



### Concrete drill bits SDS-Plus - Top sellers display

Item Number	i	📦
T3140TSBOM	stock and stand	1

CONTENTS: 6 x drill bits, sizes: 5.5 x 110, 5.5 x 160 & 7 x 160mm. 3 x drill bits, sizes: 6 x 110, 6 x 160, 6.5 x 160, 8 x 160, 8 x 260 & 10 x 160mm. 2 x drill bits, sizes: 5 x 110, 5 x 160, 6 x 210, 7 x 110, 8 x 210, 8 x 450, 10 x 210, 10 x 260, 10 x 450, 12 x 160, 12 x 210, 12 x 260, 12 x 450, 14 x 250 & 16 x 450mm.



### Concrete drill bits SDS-Plus - Full range display

Item Number	i	📦
T3140RBOM	stock and stand	1

- Forged steel with tungsten carbide tip for durability
- Optimised design for high performance drilling of concrete & stone

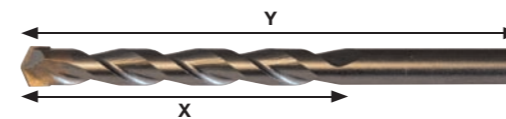

### Concrete drill bits

Item Number	Ø	X	Y	No.	📦
T3066 04	4mm	45mm	75mm	6	10
T3066 05	5mm	50mm	85mm	8	10
T3066 055	5.5mm	50mm	85mm	10	10
T3066 06	6mm	60mm	100mm	11	10
T3066 065	6.5mm	60mm	100mm	12	10
T3066 07	7mm	60mm	100mm	14	10
T3066 08	8mm	80mm	100mm	16	5
T3066 10	10mm	80mm	120mm	21	5
T3066 12	12mm	95mm	150mm	C	5
T3066 13	13mm	83mm	150mm	24	5
T3066 14	14mm	83mm	150mm	25	5
T3066 16	16mm	83mm	150mm	26	5

CONTENTS: 1 x drill bit, sizes: 4, 5.5, 6.5, 7 & 8mm.



### Concrete drill bits set - 5 Piece

Item Number	📦
T3068A	1

CONTENTS: 9 x drill bits, size: 7mm. 6 x drill bits, sizes: 5 & 5.5mm. 4 x drill bits, sizes: 6, 6.5 & 8mm.



### Concrete drill bits - Top sellers display

Item Number	i	📦
T3066TSBOM	stock and stand	1

## BRICK DRILL BITS

- Forged steel with tungsten carbide tip for durability
- Optimised design for fast & accurate drilling of brick type materials

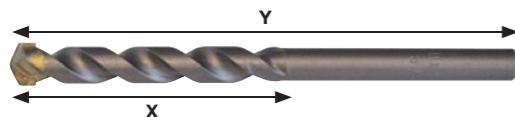

### Brick drill bits

Item Number	Ø	X	Y	
T3071M 04	4mm	38mm	75mm	5
T3071M 05	5mm	44mm	85mm	5
T3071M 055	5.5mm	44mm	85mm	5
T3071M 06	6mm	54mm	100mm	5
T3071M 065	6.5mm	54mm	100mm	5
T3071M 07	7mm	54mm	100mm	5
T3071M 08	8mm	67mm	120mm	5
T3071M 10	10mm	67mm	120mm	5
T3071M 12	12mm	85mm	150mm	5
T3071M 13	13mm	85mm	150mm	5
T3071M 14	14mm	85mm	150mm	5
T3071M 16	16mm	85mm	150mm	5
T3069 055	5.5mm	135mm	200mm	5
T3069 06	6mm	135mm	200mm	5
T3069 065	6.5mm	135mm	200mm	5
T3069 07	7mm	135mm	200mm	5
T3069 08	8mm	135mm	200mm	5
T3069 10	10mm	135mm	200mm	5
T3069 12	12mm	135mm	200mm	5
T3069 14	14mm	135mm	200mm	5

CONTENTS: 1 x drill bit, sizes: 4, 5.5, 6.5, 7 & 8mm.



### Brick drill bits set - 5 Piece

Item Number	
T3072A	3

CONTENTS: 12 x drill bits, size: 7mm. 10 x drill bits, sizes: 5 & 5.5mm. 6 x drill bits, sizes: 6, 6.5 & 8mm.



### Brick drill bits - Top sellers display

Item Number		
T3071TSBOM	stock and stand	1

## METAL DRILL BITS

- Forged HSS, precision ground for accurate drilling



### Metal drill bits - Imperial

Item Number	Ø	X	Y		
T3180 06T	1/16"	20mm	43mm	twin pack	10
T3180 07T	5/64"	24mm	49mm	twin pack	10
T3180 09T	3/32"	30mm	57mm	twin pack	10
T3180 10T	7/64"	33mm	61mm	twin pack	10
T3180 12T	1/8"	36mm	65mm	twin pack	10
T3180 14	9/64"	39mm	70mm	single pack	10
T3180 15	5/32"	43mm	75mm	single pack	10
T3180 17	11/64"	47mm	80mm	single pack	10
T3180 18	3/16"	52mm	86mm	single pack	5
T3180 21	7/32"	57mm	93mm	single pack	5
T3180 25	1/4"	63mm	101mm	single pack	5
T3180 28	9/32"	69mm	109mm	single pack	5
T3180 31	5/16"	75mm	117mm	single pack	5
T3180 37	3/8"	87mm	133mm	single pack	5
T3180 43	7/16"	94mm	142mm	single pack	5
T3180 50	1/2"	101mm	151mm	single pack	5

- Forged HSS, precision ground for accurate drilling



### Metal drill bits - Metric

Item Number	Ø	X	Y		
T3182 01T	1mm	12mm	34mm	twin pack	10
T3099 01				loose	10
T3182 015T	1.5mm	18mm	40mm	twin pack	10
T3099 015				loose	10
T3182 02T	2mm	24mm	49mm	twin pack	10
T3099 02				loose	10
T3182 025T	2.5mm	30mm	57mm	twin pack	10
T3099 025				loose	10
T3182 03T	3mm	33mm	61mm	twin pack	10
T3099 03				loose	10
T3182 035T	3.5mm	39mm	70mm	twin pack	10
T3099 035				loose	10
T3182 04T	4mm	43mm	75mm	twin pack	10
T3099 04				loose	10
T3182 045	4.5mm	47mm	80mm	single pack	10
T3099 045				loose	10
T3182 05	5mm	52mm	86mm	single pack	5
T3099 05				loose	10
T3182 055	5.5mm	57mm	93mm	single pack	5
T3099 055				loose	10
T3182 06	6mm	57mm	93mm	single pack	5
T3099 06				loose	10
T3182 065	6.5mm	63mm	101mm	single pack	5
T3099 065				loose	10
T3182 07	7mm	69mm	109mm	single pack	5
T3099 07				loose	10
T3182 075	7.5mm	69mm	107mm	single pack	5
T3099 075				loose	10
T3182 08	8mm	75mm	117mm	single pack	5
T3099 08				loose	10
T3182 085	8.5mm	75mm	117mm	single pack	5
T3099 085				loose	10
T3182 09	9mm	81mm	125mm	single pack	5
T3099 09				loose	10
T3182 085	8.5mm	75mm	117mm	single pack	5
T3099 095				loose	10
T3182 10	10mm	87mm	133mm	single pack	5
T3099 10				loose	10
T3182 105	10.5mm	87mm	133mm	single pack	5
T3099 105				loose	5
T3182 11	11mm	94mm	142mm	single pack	5
T3099 11				loose	5
T3182 115	11.5mm	94mm	142mm	single pack	5
T3099 115				loose	5

Continued in the next column

T3182 12	12mm	101mm	151mm	single pack	5
T3099 12				loose	5
T3182 125	12.5mm	101mm	151mm	single pack	5
T3099 125				loose	5
T3182 13	13mm	101mm	151mm	single pack	5
T3099 13				loose	5

CONTENTS: 1 x drill bit, sizes: 1, 1.5, 2, 2.5, 3, 3.5, 4, 4.5, 5, 5.5, 6, 6.5, 7, 7.5, 8, 8.5, 9, 9.5 & 10mm.



### Metal drill bits set - 19 Piece

Item Number	
T3191	3

CONTENTS: 1 x drill bit, sizes: 1.5, 2, 2.5, 3, 3.2, 3.5, 4, 4.5, 4.8, 5, 5.5, 6 & 6.5mm.



### Metal drill bits set - 13 Piece

Item Number	
T3058	3

CONTENTS: 1 x drill bit, sizes: 2, 3, 4, 5, 6 & 8mm.



**Metal drill bits set - 6 Piece**

Item Number	
T3098-6	3

- Forged HSS, precision ground for accurate drilling
- Titanium nitride coated for extra wear protection

CONTENTS: 1 x drill bit, sizes: 1, 1.5, 2, 2.5, 3, 3.5, 4, 4.5, 5, 5.5, 6, 6.5, 7, 7.5, 8, 8.5, 9, 9.5 & 10mm.



**Metal drill bits TiN coated set - 19 Piece**

Item Number	
T3291	3

- Forged HSS, precision ground for accurate drilling
- Titanium nitride coated for extra wear protection

CONTENTS: 1 x drill bit, sizes: 2, 3, 4, .5, 6 & 8mm.



**Metal drill bits TiN coated set - 6 Piece**

Item Number	
T3293	3

CONTENTS: 8 x drill bits, twin pack, sizes: 3 & 3.5mm. 6 x drill bits, twin pack, sizes: 2.5 & 4mm. 8 x drill bits, size: 5mm. 3 x drill bits, size: 6mm.



**Metal drill bits, metric - Top sellers display**

Item Number	
T3182SBOM	stock and stand 1

CONTENTS: 8 x drill bits, twin packs, sizes: 3 & 3.5mm. 6 x drill bits, twin packs, sizes: 1, 1.5, 2, 2.5 & 4mm. 8 x drill bits, size: 5mm. 6 x drill bits, sizes: 4.5 & 5.5mm. 3 x drill bits, sizes: 6, 6.5, 7, 8, 9, 10, 12 & 13mm.



**Metal drill bits, metric - Full range display**

Item Number	
T3182RBOM	stock and stand 1

- HSS, precision ground for accurate drilling
- Dual flute construction for faster drilling & longer life



**Multistep drill bits**

Item Number	
T3008	6, 9, 12.3, 15.2, 18.6, 20.4, 22.5, 25.4, 28.3 & 30.5mm 1
T3010 2	6, 8, 10, 12, 14, 16, 18, 20, 22, 24, 28 & 30mmØ 1
T3009	4, 5, 6, 7, 8, 9, 10, 11 & 12mmØ 1
T3010 1	4, 6, 8, 10, 12, 14, 16, 18 & 20mmØ 1

**MULTIPURPOSE DRILL BITS**

CONTENTS: 1 x brick drill bit, sizes: 4, 5.5, 6.5, 7 & 8mm. 1 x metal drill bit, sizes: 2, 3, 4, 5, 6 & 8mm. 1 x wood drill bit, sizes: 4, 5, 6, 8 & 10mm.

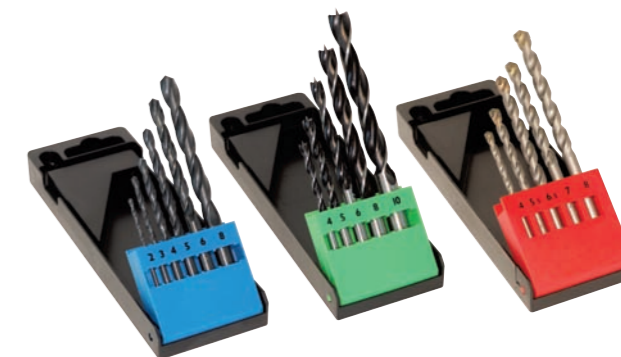

**Brick, metal & wood drill bit set - 16 Piece**

Item Number	
T3064A	3

- Tungsten carbide tipped drills specially designed for drilling through concrete, brick, cement, stone, metal & ceramics

CONTENTS: 1 x drill bit, sizes: 4, 5, 6, 8 & 10mm.

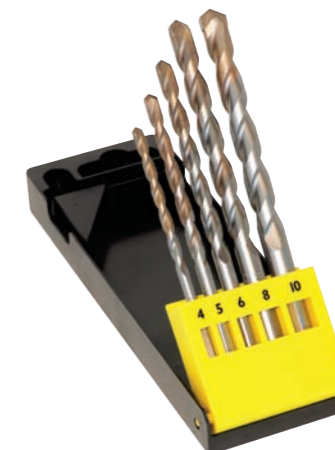

**Universal drill bit set - 5 Piece**

Item Number	
T3063	3

- Titanium nitride coated HSS for strength and durability
- Drills and cuts to create any size shape or hole
- Cuts through wood/plastic up to 5mm, aluminium up to 4mm and metal up to 3mm thick



**Drill saw**

Item Number	
T3193T	6mm 20

# FAST4

**4 FLUTES = FASTER DRILLING**  
**4 SCHNEIDEN = SCHNELLERES BOHREN**  
**4 LAMES = PERÇAGE PLUS RAPIDE**  
**4 FLAUTAS = PERFORACIÓN MÁS RÁPIDA**



**1 4 blades offering 100% more cutting blade than a flat bit for faster drilling**

4 Schneiden bieten für schnelleres Bohren doppelt soviel Kapazität als ein Flachbohrer

4 lames offrant 100 % de tranchants en plus par rapport aux mèches plates, pour un perçage plus rapide

4 hojas que permiten disponer de un 100% más de corte que con un trépano plano, para una perforación más rápida

**2 Optimised flute geometry for faster waste removal**

Optimierte Geometrie der Spannuten für schnelleres Entfernen der Späne

Géométrie optimisée des cannelures pour un enlèvement plus rapide des copeaux

Geometría escalonada y optimizada para conseguir una eliminación más rápida de los residuos

**3 Precision ground cutting edges with outer spur blades for a smoother cut & cleaner breakout**

Präzise geschliffene Schneidkanten mit äußeren Führungsschneiden für glatte Bohrlöcher mit sauberen Durchbruch

Arêtes coupantes à rectification de précision avec lames extérieures en pointe pour une coupe plus lisse et un débouchage plus propre

Bordes de corte con amolado de precisión, con hojas externas de rebarbado para un inicio más limpio y más suave del corte

**4 Screw point allows accurate positioning & pulls the bit through with less effort**

Schraubspitze ermöglicht genaues Ansetzen und einfache Führung beim Bohren

La pointe de centrage à vis permet un positionnement précis et entraîne la mèche avec moins d'efforts

Punta de tornillo que permite un posicionamiento preciso y hacer pasar el trépano con menos esfuerzo



# Fast4

## FAST4

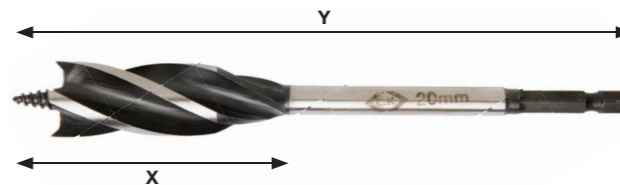

### Fast4 drill bits

Item Number	Ø	X	Y	📦
T2943-16	16mm	110mm	160mm	10
T2943-20	20mm	110mm	160mm	10
T2943-22	22mm	110mm	160mm	10
T2943-25	25mm	110mm	160mm	10
T2943-32	32mm	110mm	160mm	10

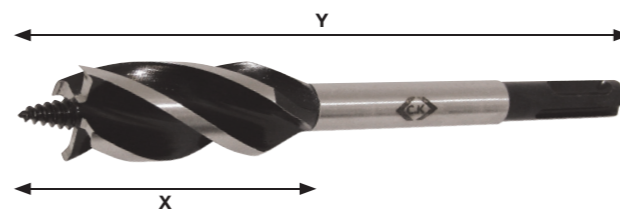

### Fast4 drill bits SDS-Plus

Item Number	Ø	X	Y	📦
T2944-16	16mm	110mm	160mm	10
T2944-20	20mm	110mm	160mm	10
T2944-22	22mm	110mm	160mm	10
T2944-25	25mm	110mm	160mm	10
T2944-32	32mm	110mm	160mm	10

CONTENTS: 5 x drill bits, size: 25mm. 3 x drill bits, size: 20mm. 2 x drill bits, sizes: 16, 22 & 32mm.



### Fast4 drill bits - Full range displays

Item Number	i	i	📦
T2943RBOM	standard	stock and stand	1
T2944RBOM	SDS-Plus	stock and stand	1

## WOOD DRILL BITS

- Chrome vanadium steel for long life performance
- Brad pointed for accurate drill starts
- Spur ground external edge for clean hole cutting

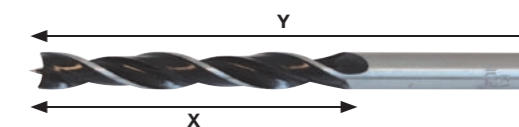

### Wood drill bits

Item Number	Ø	X	Y	📦
T3035 03	3mm	33mm	61mm	10
T3035 04	4mm	43mm	75mm	10
T3035 05	5mm	52mm	86mm	5
T3035 06	6mm	60mm	97mm	5
T3035 08	8mm	75mm	117mm	5
T3035 10	10mm	87mm	133mm	5
T3035 12	12mm	96mm	151mm	5
T3035 13	13mm	96mm	151mm	5
T3035 14	14mm	97mm	151mm	5
T3035 16	16mm	100mm	160mm	3

CONTENTS: 1 x drill bit, sizes: 4, 5, 6, 8 & 10mm.

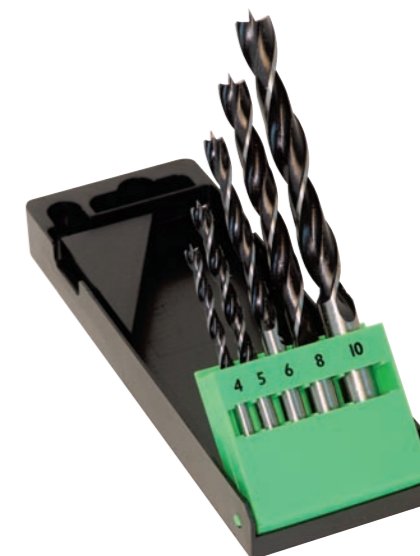

### Wood drill bits set - 5 Piece

Item Number	📦
T3040	3

CONTENTS: 6 x drill bits, sizes: 3, 4 & 5mm. 3 x drill bits, sizes: 6, 8 & 10mm.



Wood drill bits - Top sellers display

Item Number	i	Stock and stand	1
T3035TSBOM		stock and stand	1

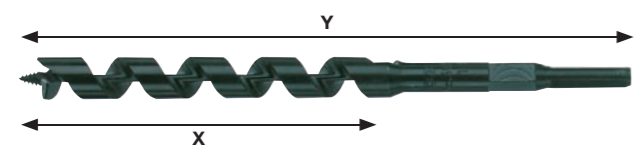

Auger bits - Standard

Item Number	Ø	X	Y	6
T3031 06	6mm	90mm	160mm	6
T3031 08	8mm	100mm	170mm	6
T3031 10	10mm	120mm	190mm	6
T3031 13	13mm	120mm	190mm	6
T3031 16	16mm	130mm	200mm	6
T3031 20	20mm	140mm	210mm	6
T3031 22	22mm	140mm	210mm	6
T3031 25	25mm	140mm	210mm	6
T3031 30	30mm	140mm	210mm	6
T3031 32	32mm	140mm	210mm	6

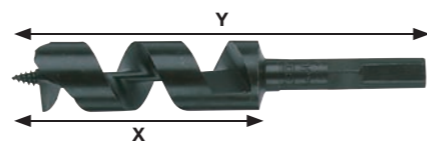

Auger bits - Short

Item Number	Ø	X	Y	6
T3033 13	13mm	50mm	100mm	6
T3033 16	16mm	70mm	120mm	6
T3033 20	20mm	80mm	130mm	6
T3033 22	22mm	80mm	130mm	6
T3033 25	25mm	80mm	130mm	6
T3033 32	32mm	80mm	140mm	6

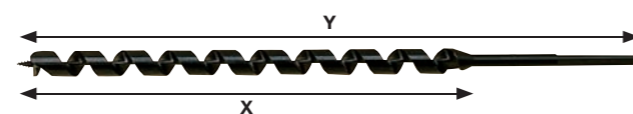

Auger bits - Long

Item Number	Ø	X	Y	6
T3034 10	10mm	220mm	300mm	6
T3034 13	13mm	220mm	300mm	6
T3034 16	16mm	220mm	300mm	6
T3034 20	20mm	220mm	300mm	6
T3034 22	22mm	220mm	300mm	6
T3034 25	25mm	220mm	300mm	6

CONTENTS: 2 x auger bits, sizes: 10, 20 & 25mm. 1 x auger bit, sizes: 13, 16 & 22mm.



Auger bits, standard - Top sellers display

Item Number	i	Stock and stand	1
T3031TSBOM		stock and stand	1

- HSS, hardened for long life performance
- Brad pointed for accurate drill starts
- Ground wing spur for clean hole cutting
- Quick lock direct E6.3 drive

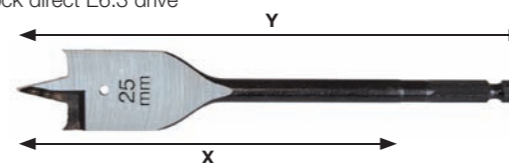

Flat bits - standard

Item Number	Ø	X	Y	5
T2942-06	6mm	130mm	160mm	5
T2942-08	8mm	130mm	160mm	5
T2942-10	10mm	130mm	160mm	5
T2942-12	12mm	130mm	160mm	5
T2942-13	13mm	130mm	160mm	5
T2942-14	14mm	130mm	160mm	5
T2942-16	16mm	130mm	160mm	5
T2942-20	20mm	130mm	160mm	5
T2942-22	22mm	130mm	160mm	5
T2942-25	25mm	130mm	160mm	5
T2942-28	28mm	130mm	160mm	5
T2942-32	32mm	130mm	160mm	5
T2942-38	38mm	130mm	160mm	5

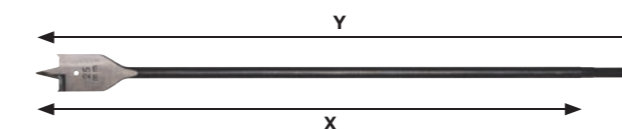

Flat bits - long

Item Number	Ø	X	Y	5
T2942-12400	12mm	370mm	400mm	5
T2942-16400	16mm	370mm	400mm	5
T2942-20400	20mm	370mm	400mm	5
T2942-25400	25mm	370mm	400mm	5
T2942-32400	32mm	370mm	400mm	5

- Extension drive shaft for flat bits with E6.3 drive



Flat bits extension drive - Quick lock

Item Number	300mm	5
T2940-2	300mm	5

CONTENTS: 1 x flat bit, sizes: 10, 13, 16, 20, 22 & 25mm.



Flat bits set - 6 Piece

Item Number	5
T2942P	5

- HSS, hardened for long life performance



Countersink bits

Item Number	10 x 90°	6
T2601S 3760	10 x 90°	6
T2601S 5090	13 x 90°	6

CONTENTS: 3 x flat bits, sizes: 20 & 25mm. 2 x flat bits, sizes: 13, 16 & 22mm. 1 x flat bit, size: 32mm.



Flat bits, standard - Top sellers display

Item Number	i	Stock and stand	1
T2942TSBOM		stock and stand	1

## HOLESAWS

- HSS bi-metal holesaw with hardened vari-pitch teeth for the fast clean cutting of metal, wood, plastic & composite materials



### Holesaws

Item Number	Ø	
424001	16mm 5/8"	10
424002	19mm 3/4"	10
424003	20mm 29/32"	10
424005	22mm 7/8"	10
424006	25mm 1"	10
424007	29mm 1 1/8"	10
424008	32mm 1 1/4"	10
424010	38mm 1 1/2"	10
424011	40mm 1 9/16"	10
424012	41mm 1 5/8"	10
424013	43mm 1 11/16"	10
424014	44mm 1 3/4"	10
424015	48mm 1 7/8"	10
424016	51mm 2"	10
424017	54mm 2 1/8"	10
424018	57mm 2 1/4"	10
424019	60mm 2 3/8"	10
424020	64mm 2 1/2"	10
424021	65mm 2 9/16"	10
424022	67mm 2 5/8"	10
424024	70mm 2 3/4"	10
424025	73mm 2 7/8"	10
424026	76mm 3"	10
424027	79mm 3 1/8"	10
424028	83mm 3 1/4"	10
424029	86mm 3 3/8"	10
424030	89mm 3 1/2"	10
424031	92mm 3 5/8"	10
424032	95mm 3 3/4"	10
424033	102mm 4"	10
424034	105mm 4 1/8"	10
424035	111mm 4 3/8"	10
424036	114mm 4 1/2"	10

## HOLESAW ARBORS & ACCESSORIES

- For use with holesaws up to 30mm
- Supplied with replaceable 1/4" HSS pilot drill



### Arbor - For 14-30mm holesaws

Item Number	Ø	
424037	8mm 5/16"	10
424038	11mm 7/16"	10

- For use with holesaws up to 30mm
- Supplied with replaceable 1/4" HSS pilot drill



### Arbor SDS-Plus - For 14-30mm holesaws

Item Number		
424047		10

- Quick-release mechanism for fast holesaw interchange
- For use with holesaws from 32mm - 114mm
- Supplied with replaceable 1/4" HSS pilot drill



### Arbor quick release - For 32-114mm holesaws

Item Number	Ø	
424039	11mm 7/16"	10

- Quick-release mechanism for fast holesaw interchange
- For use with holesaws up to 33mm
- Supplied with replaceable 1/4" HSS pilot drill



### Arbor SDS-Plus quick release - For 32-114mm holesaws

Item Number		
424048		10

- For use with holesaws from 32mm - 114mm
- Supplied with replaceable 1/4" HSS pilot drill



### Arbor locking - For 32-114mm holesaws

Item Number	Ø	
424040	11mm 7/16"	10

- For use with all 11mm hexagonal shaft arbors



### 300mm Extension Drive - For 11mm arbor

Item Number	Ø	Length	
424049	11mm 7/16"	300mm	10

- Replacement HSS pilot drill bit for holesaw arbor 424037, 424047 & 424048



### Replacement pilot drill

Item Number		
424041		10

- Replacement HSS pilot drill bit for holesaw arbor 424038, 424039 & 424040



### Replacement pilot drill

Item Number		
424042		10

CONTENTS: 1 x holesaw, sizes: 16, 19, 20, 22, 25, 29, 32, 38, 40, 44, 48, 51, 54, 57, 60, 64, 65, 67, 70, 73, 76, 79, 83, 89, 92, 95, 102, 105, 111 & 114mm. 1 x arbor 14-30mm (8mm shaft). 1 x arbor 14-30mm (11mm shaft). 1 x quick release arbor 32-114mm (11mm shaft). 1 x locking arbor 32-114mm (11mm shaft). 1 x SDS arbor 14-30mm. 1 x SDS quick release arbor 32-114mm. 1 x replacement pilot drill (for 424037, 424047 & 424048). 1 x replacement pilot drill (for 424038, 424039 & 424040). 1 x extension drive.



### Holesaws & accessories - Range display

Item Number	i	
400002	stock and stand	1



## HOLESAW KITS

CONTENTS: 1 x holesaw, sizes: 16, 20, 25, 32, 38 & 51mm. Arbor 14-30mm (8mm shaft). Quick release arbor 32-114mm (11mm shaft). Hexagon key 4mm.



**Holesaw kit - 9 Piece electrician**

Item Number	
424045	1

CONTENTS: 1 x holesaw, sizes: 65, 70, 76 & 83mm. Quick release arbor 32-114mm (11mm shaft). Hexagon key 4mm.



**Holesaw kit - 6 Piece downlight**

Item Number	
424046	1

CONTENTS: 1 x holesaw, sizes: 22, 29, 35, 44, 51 & 64mm. Arbor 14-30mm (8mm shaft). Locking arbor 32-114mm (11mm shaft). Hexagon key 4mm.



**Holesaw kit - 9 Piece**

Item Number	
424043	1

CONTENTS: 1 x holesaw, sizes: 40, 54, 65, 67 & 68mm. Quick release arbor 32-114mm (11mm shaft).



**Holesaw kit - 6 Piece**

Item Number	
424044	1

## SCREWDRIVER BITS - STANDARD

- Premium quality chrome vanadium steel for exceptional strength & durability
- Precision machined tip for an exact screw fit & damage free screwdriving

featuring GRIP-TIP technology



## SCREWDRIVER BITS

1 GRIP-TIP™ anti cam-out ribs reduce the risk of slipping



DIN 3126-C6,3  
ISO 1173 Drive

DIN 3126-E6,3  
ISO 1173 Drive

featuring GRIP-TIP technology

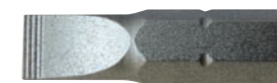

## Screwdriver bits - Slotted

DIN ISO 1173

Item Number				
T4550-0645T	25mm	0.6 x 4.5mm	carded pair	5
T4550 0645			loose	10
T4550-0855T	25mm	0.8 x 5.5mm	carded pair	5
T4550 0855			loose	10
T4550-1055T	25mm	1.0 x 5.5mm	carded pair	5
T4550 1055			loose	10
T4550-1265T	25mm	1.2 x 6.5mm	carded pair	5
T4550 1265			loose	10

featuring GRIP-TIP technology



## Screwdriver bits - PZ

DIN ISO 1173

Item Number				
T4562 1	25mm	PZ1	carded pair	25
T4552 1			loose	10
T4562 2	25mm	PZ2	carded pair	25
T4552 2			loose	10
T4562 3	25mm	PZ3	carded pair	25
T4552 3			loose	10
T4562 4	25mm	PZ4	carded pair	25
T4552 4			loose	10



## Screwdriver bits - PZ box of 15

DIN ISO 1173

Item Number			
T4562-215	25mm	PZ2	6



## Screwdriver bits - PZ counterbox of 12

DIN ISO 1173

Item Number			
T4562-2CB	25mm	PZ2	1





featuring GRIP-TIP technology



### Screwdriver bits - PH

DIN ISO 1173

Item Number	Length	Size	Configuration	Quantity
T4561 1	25mm	PH1	carded pair	5
T4551 1	25mm		loose	10
T4561 2	25mm	PH2	carded pair	5
T4551 2	25mm		loose	10
T4561 3	25mm	PH3	carded pair	5
T4551 3	25mm		loose	10



### Screwdriver bits - Robertson

DIN ISO 1173

Item Number	Length	Size	Configuration	Quantity
T4553 1	25mm	1		10
T4553 2	25mm	2		10
T4553 3	25mm	3		10



### Screwdriver bits - Hexagon

DIN ISO 1173

Item Number	Length	Size	Configuration	Quantity
T4554 25	25mm	2.5mm	loose	10
T4554-3T	25mm	3.0mm	carded pair	5
T4554 3			loose	10
T4554-4T	25mm	4.0mm	carded pair	5
T4554 4			loose	10
T4554-5T	25mm	5.0mm	carded pair	5
T4554 5			loose	10
T4554-6T	25mm	6.0mm	carded pair	5
T4554 6			loose	10



### Screwdriver bits - TX

DIN ISO 1173

Item Number	Length	Size	Configuration	Quantity
T4557-05T	25mm	TX05	carded pair	5
T4557 05			loose	10
T4557-06T	25mm	TX06	carded pair	5
T4557 06			loose	10
T4557-07T	25mm	TX07	carded pair	5
T4557 07			loose	10
T4557-08T	25mm	TX08	carded pair	5
T4557 08			loose	10
T4557-09T	25mm	TX09	carded pair	5
T4557 09			loose	10
T4557-10T	25mm	TX10	carded pair	5
T4557 10			loose	10
T4557-15T	25mm	TX15	carded pair	5
T4557 15			loose	10
T4557-20T	25mm	TX20	carded pair	5
T4557 20			loose	10
T4557-25T	25mm	TX25	carded pair	5
T4557 25			loose	10
T4557-27T	25mm	TX27	carded pair	5
T4557 27			loose	10
T4557-30T	25mm	TX30	carded pair	5
T4557 30			loose	10
T4557-40T	25mm	TX40	carded pair	5
T4557 40			loose	10



### Screwdriver bits - TX tamperproof

DIN ISO 1173

Item Number	Length	Size	Configuration	Quantity
T4557T-10T	25mm	TX10	carded pair	5
T4557T 10			loose	10
T4557T-15T	25mm	TX15	carded pair	5
T4557T 15			loose	10
T4557T-20T	25mm	TX20	carded pair	5
T4557T 20			loose	10
T4557T-25T	25mm	TX25	carded pair	5
T4557T 25			loose	10
T4557T-30T	25mm	TX30	carded pair	5
T4557T 30			loose	10

featuring GRIP-TIP technology



### Screwdriver bits - PZ long

DIN ISO 1173

Item Number	Length	Size	Configuration	Quantity
T4556-1T	50mm	PZ1	carded pair	5
T4556 1			loose	10
T4556-2T	50mm	PZ2	carded pair	5
T4556 2			loose	10

featuring GRIP-TIP technology



### Screwdriver bits - PH long

DIN ISO 1173

Item Number	Length	Size	Configuration	Quantity
T4555-1T	50mm	PH1	carded pair	5
T4555 1			loose	10
T4555-2T	50mm	PH2	carded pair	5
T4555 2			loose	10



### Screwdriver bits - Modulo

Item Number	Size	Configuration	Quantity
422001	1 & 2	carded pair	10
T4545 1	1	loose	20
T4545 2	2	loose	20

featuring GRIP-TIP technology



### Screwdriver bits - PZ/slotted

Item Number	Length	Size	Configuration	Quantity	
T4579-1T	50mm	PZ1	4mm	carded pair	5
T4579-2T	50mm	PZ2	7mm	carded pair	5

CONTENTS: Screwdriver bit holder. 5 x screwdriver bits, carded pairs, PZ size: 2 x 25mm. 3 x screwdriver bits, carded pairs, PZ sizes: 1 x 25, 2 x 50 & 3 x 25mm. 1 x screwdriver bits, box of 15, PZ, size: 2.



### Screwdriver bits - Top sellers display

Item Number	Configuration	Quantity
T4562TSBOM	stock and stand	1

### SCREWDRIVER BIT SETS

CONTENTS: Screwdriver bit holder. 1 x screwdriver bits, slotted, sizes: 3, 4, 4.5, 5, 5.5, 6, 7, 8 & 9mm; PZ, sizes: 0, 1, 2 & 3; PH, sizes: 0, 1, 2, & 3; TX, sizes: 8, 10, 15, 20, 25, 27, 30 & 40; Hexagon, sizes: 1.5, 2, 2.5, 3, 4, 5, 5.5 & 6mm.



### Screwdriver bit clip set - 33 Piece

DIN ISO 1173

Item Number	Quantity
T4520	6

CONTENTS: 1 x screwdriver bit, slotted, sizes: 3, 4, 4.5, 5, 6, 7, 8 & 9mm.

featuring GRIP-TIP technology

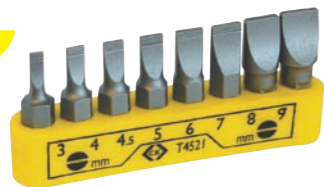

**Screwdriver bit clip set - 8 Piece slotted**

Item Number	
T4521	6

CONTENTS: 1 x screwdriver bit, PZ, sizes: 0, 1, 2 & 3; PH, sizes: 0, 1, 2 & 3.

featuring GRIP-TIP technology



**Screwdriver bit clip set - 8 Piece PH/PZ**

Item Number	
T4522	6

CONTENTS: 1 x screwdriver bit, TX, sizes: 8, 10, 15, 20, 25, 27, 30 & 40.



**Screwdriver bit clip set - 8 Piece TX**

Item Number	
T4523	6

CONTENTS: 1 x screwdriver bit, TX tamperproof, sizes: 8, 10, 15, 20, 25, 27, 30 & 40.



**Screwdriver bit clip set - 8 Piece TX tamperproof**

Item Number	
T4527	6

CONTENTS: 1 x screwdriver bit, hexagon, sizes: 1.5, 2, 2.5, 3, 4, 5, 5.5 & 6mm.



**Screwdriver bit clip set - 8 Piece hexagon**

Item Number	
T4524	6

CONTENTS: 1 x screwdriver bit, hexagon tamperproof, sizes: 2, 2.5, 3, 4, 5, 5.5, 6 & 7mm.



**Screwdriver bit clip set - 8 Piece hexagon tamperproof**

Item Number	
T4528	6

CONTENTS: 1 x screwdriver bit, slotted, sizes: 4.5 & 7mm; PZ, sizes: 1, 2 & 3; PH, sizes: 1, 2 & 3; TX, sizes: 15 & 20.

featuring GRIP-TIP technology



**Screwdriver bit clip set - 10 Piece SL/PH/PZ/TX**

Item Number		
T4525	100mm	6

CONTENTS: Screwdriver bit holder. 1 x screwdriver bit, slotted, sizes: 4.5, 5.5, 6.5mm; TX, sizes: 10, 15, 20, 25, 30 & 40; Hexagon, sizes: 3, 4 & 5mm. 3 x screwdriver bits, PZ, sizes 1, 2 & 3; PH, sizes: 1, 2 & 3.

featuring GRIP-TIP technology



**Screwdriver bit boxed set - 31 Piece**

Item Number	
T4566	5

CONTENTS: Screwdriver bit holder. Quick change chuck. 1 x screwdriver bit, slotted, sizes: 4, 5, 6, & 7mm; PZ, sizes: 1, 2 & 3; PH, sizes: 1, 2 & 3; TX, sizes: 10, 15, 20, 25, 30 & 40; Hexagon, sizes: 3, 4, 5, & 6mm. 2 x drill/driver bits, sizes: 2.5mm x PZ1 & 3.0mm x PZ2. 1 x drill/driver bit, size: 4.0mm x PZ3.



**Screwdriver bit & drill set - Quick change**

Item Number	
T4519	6

CONTENTS: Screwdriver bit holder. 1 x screwdriver bit, slotted, sizes: 5.5 & 6.5mm; PZ, sizes: 1 & 2; PH, sizes: 1 & 2.

featuring GRIP-TIP technology



**Screwdriver bit boxed set - 7 Piece**

Item Number	
T4583C	5

- Designed for the fast removal of damaged non hardened screws
- Hexagon shaft for use with reversible drill
- Pack contains two sizes for screws 6 – 10 & 12 – 14

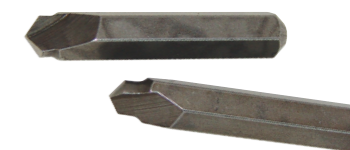

**Damaged screw removers**

Item Number	
422003	12



**Damaged screw remover - Displays**

Item Number		
T3060-CBOX	clipstrip x 6	1
T3060-CLIP	counterbox x 12	1

## SCREWDRIVER BITS - TIN COATED

featuring GRIP-TIP technology



### Screwdriver bits - TiN coated - PZ

DIN ISO 1173

Item Number	Length	Tip	Material	Quantity
T4562TIN 1	25mm	PZ1	carded pair	5
T4552TIN 1			loose	10
T4562TIN 2	25mm	PZ2	carded pair	5
T4552TIN 2			loose	10
T4562TIN 3	25mm	PZ3	carded pair	5
T4552TIN 3			loose	10



### Screwdriver bits - TiN coated - PZ box of 15

Item Number	Length	Tip	Quantity
T4562TIN-215	25mm	PZ2	6



### Screwdriver bits - TiN coated - PZ counterbox of 12

Item Number	Length	Tip	Quantity
T4562TIN-2CB	25mm	PZ2	1

featuring GRIP-TIP technology



### Screwdriver bits - TiN coated - PH

DIN ISO 1173

Item Number	Length	Tip	Material	Quantity
T4561TIN 1	25mm	PH1	carded pair	5
T4551TIN 1			loose	10
T4561TIN 2	25mm	PH2	carded pair	5
T4551TIN 2			loose	10
T4561TIN 3	25mm	PH3	carded pair	5
T4551TIN 3			loose	10



### Screwdriver bits - TiN coated - TX

DIN ISO 1173

Item Number	Length	Tip	Material	Quantity
T4557TIN-10T	25mm	TX10	carded pair	5
T4557TIN 10			loose	10
T4557TIN-15T	25mm	TX15	carded pair	5
T4557TIN 15			loose	10
T4557TIN-20T	25mm	TX20	carded pair	5
T4557TIN 20			loose	10
T4557TIN-25T	25mm	TX25	carded pair	5
T4557TIN 25			loose	10
T4557TIN-30T	25mm	TX30	carded pair	5
T4557TIN 30			loose	10
T4557TIN-40T	25mm	TX40	carded pair	5
T4557TIN 40			loose	10

featuring GRIP-TIP technology



### Screwdriver bits - TiN coated - PZ long

DIN ISO 1173

Item Number	Length	Tip	Material	Quantity
T4556TIN-1T	50mm	PZ1	carded pair	5
T4556TIN 1			loose	10
T4556TIN-2T	50mm	PZ2	carded pair	5
T4556TIN 2			loose	10

featuring GRIP-TIP technology



### Screwdriver bits - TiN coated - PH long

DIN ISO 1173

Item Number	Length	Tip	Material	Quantity
T4555TIN 1T	50mm	PH1	carded pair	5
T4555TIN 2T	50mm	PH2	carded pair	5

featuring GRIP-TIP technology



### Screwdriver bits - TiN coated - PZ/slotted

Item Number	Length	Tip	Width	Material	Quantity
T4579TIN-1T	50mm	PZ1	4mm	carded pair	5
T4579TIN-2T	50mm	PZ2	7mm	carded pair	5

featuring GRIP-TIP technology



### Screwdriver bits - TiN coated - PH/slotted

Item Number	Length	Tip	Width	Material	Quantity
T4580TIN-1T	50mm	PH1	4mm	carded pair	5
T4580TIN-2T	50mm	PH2	7mm	carded pair	5

CONTENTS: 1 x Screwdriver bit holder. 1 x screwdriver bit, PZ, sizes: 1 & 3. 4 x screwdriver bits, PZ, size: 2.

featuring GRIP-TIP technology



### Screwdriver bits - TiN coated boxed set - 7 Piece

Item Number	Quantity
T4569TINC	20

CONTENTS: 2 x screwdriver bit holders. 5 x screwdriver bits, carded pairs, PZ size: 2 x 25mm. 3 x screwdriver bits, carded pairs, PZ sizes: 1 x 25, 2 x 50 & 3 x 25mm. 1 x screwdriver bits, box of 15, PZ, size: 2.



### Screwdriver bits - TiN coated - Top sellers display

Item Number	Description	Quantity
T4562TINTSBOM	stock and stand	1

## SCREWDRIVER BIT HOLDERS

- Stainless steel - strong & corrosion resistant
- Magnetic base for bit retention



### Screwdriver bit holder

DIN 7427

Item Number	Length	Quantity
T4570	60mm	10

- Stainless steel - strong & corrosion resistant
- Magnetic base for bit retention



### Screwdriver bit holder - SDS-Plus

DIN 7427

Item Number	Length	Quantity
T4564SDSC	74mm	10

- Quick locking mechanism for secure bit retention
- Free rotating collar can be held in use for extra control
- Quick release mechanism for fast & convenient bit changes



### Screwdriver bit holder - Quick lock

DIN 7427

Item Number	Length	Quantity
T4564EC	51mm	10

- Magnetically holds screw to bit for fast & repetitive screw driving
- Free rotating collar can be held in use for extra control

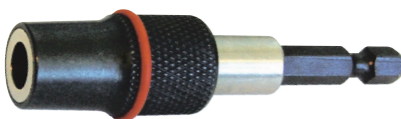

### Screwdriver bit holder - Magnetic

Item Number	Length	Quantity
T4565	60mm	10

- Magnetic holder for bit retention



### Screwdriver bit hand driver

Item Number	Quantity
T4581	6

- Commonly used for driving panel fixings



### Nut driver - Magnetic

Item Number	Size	Retention	Quantity
T4598	8mm	loose	10
T4598C 08	8mm	carded	10



### Keyless chuck - 1/4" hex drive

Item Number	Length	Quantity
T2463	6mm	10

## JIGSAW BLADES



### Jigsaw blade (5 pack) - Type B

Wood, fast coarse cuts

Item Number	Length	Thickness	Width	Material	Quantity
T0865B	75mm	2.5mm	5 - 60mm	T111C	5



### Jigsaw blade (5 pack) - Type C

Wood, precise cuts

Item Number	Length	Thickness	Width	Material	Quantity
T0865C	75mm	2.5mm	4 - 30mm	T101B	5



### Jigsaw blade (5 pack) - Type L

Wood, fast clean cuts

Item Number	Length	Thickness	Width	Material	Quantity
T0865L	75mm	4mm	6 - 60mm	T101D	5



### Jigsaw blade (5 pack) - Type P

Wood, fast extra clean cuts

Item Number	Length	Thickness	Width	Material	Quantity
T0865P	95mm	4mm	8 - 75mm		5



### Jigsaw blade (5 pack) - Type R

Wood laminates, down cut

Item Number	Length	Thickness	Width	Material	Quantity
T0865R	75mm	2.5mm	4 - 30mm	T101BR	5



### Jigsaw blade (5 pack) - Type T

Wood, extra clean curved cuts

Item Number	Length	Thickness	Width	Material	Quantity
T0865T	75mm	2.5mm	4 - 30mm	T244D	5



### Jigsaw blade (5 pack) - Type X

Wood, fast double cut

Item Number	Length	Thickness	Width	Material	Quantity
T0865X	75mm	2.0mm	3 - 60mm		5



### Jigsaw blade (5 pack) - Type A

Thin metal, straight cuts

Item Number	Length	Thickness	Width	Material	Quantity
T0865A	50mm	2.5mm	1.5 - 3mm	T118A	5



### Jigsaw blade (5 pack) - Type H

Thicker metal, straight cuts

Item Number	Length	Thickness	Width	Material	Quantity
T0865H	50mm	1.2mm	3 - 60mm	T118B	5

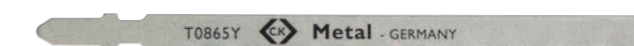

### Jigsaw blade (5 pack) - Type Y

Metal & sandwich materials

Item Number	Length	Thickness	Width	Material	Quantity
T0865Y	110mm	1.2mm	1.5 - 3mm	T318A	5

- For straight cuts in soft & hardwood, wood with nails, steel, aluminium, laminate, plastics and particle board



### Jigsaw blade (5 pack) - Type W

Universal

Item Number	Length	Thickness	Width	Material	Quantity
T0865W	110mm	1.8 - 2.5mm	3 - 100mm		5

CONTENTS: 3 x jigsaw blade packs, types: A, B, C, L, R, T, W, X & Y.



### Jigsaw blades - Range display

Item Number	Description	Quantity
T0865RBOM	stock and stand	1

### HOSE PIPES

SCHLÄUCHE  
TUYAUX SOUPLES  
MANGUERAS

138

### HOSE CONNECTORS

SCHLAUCHKUPPLUNGEN  
RACCORDS DE FLEXIBLE  
CONECTORES DE MANGUERA

139-140

### HOSE ACCESSORIES

SCHLAUCHZUBEHÖR  
ACCESSOIRES POUR FLEXIBLES  
ACCESORIOS DE MANGUERA

140-141

# WATERING SYSTEMS

WASSERSYSTEME  
RÉSEAUX D'ALIMENTATION EN EAU  
SISTEMAS DE AGUA

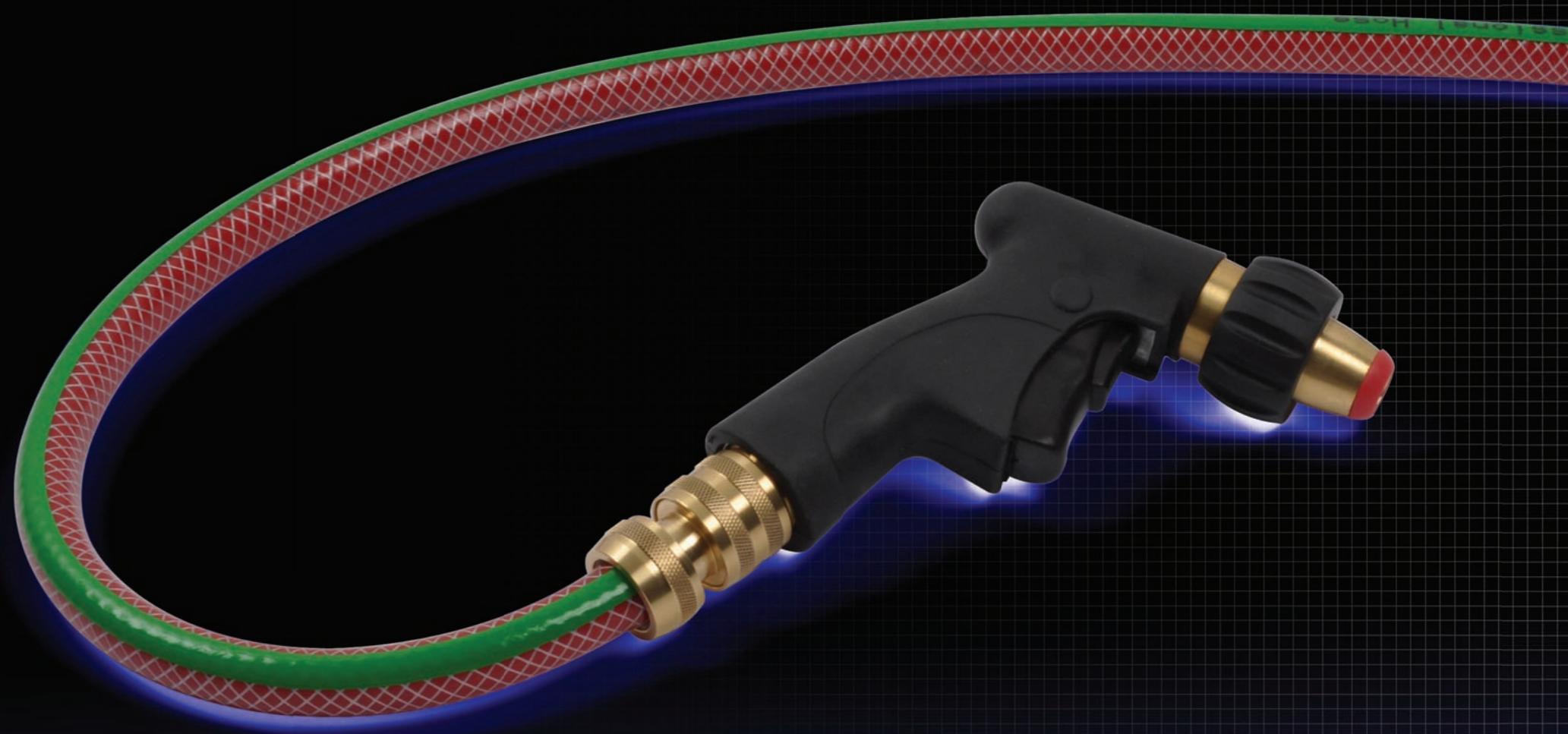



## WATER SYSTEMS

The range of C.K hose connectors is precision engineered to be long lasting and leak free. The fittings are solid brass, so are much more hard wearing than plastic systems, and are rust resistant. They are compatible with all popular makes of hoses of both 1/2" and 3/4" bores.

- 1 Solid brass - tough & corrosion resistant
- 2 Ball bearing locking - secure & hardwearing
- 3 Threaded clamp for a secure fit to hosepipe

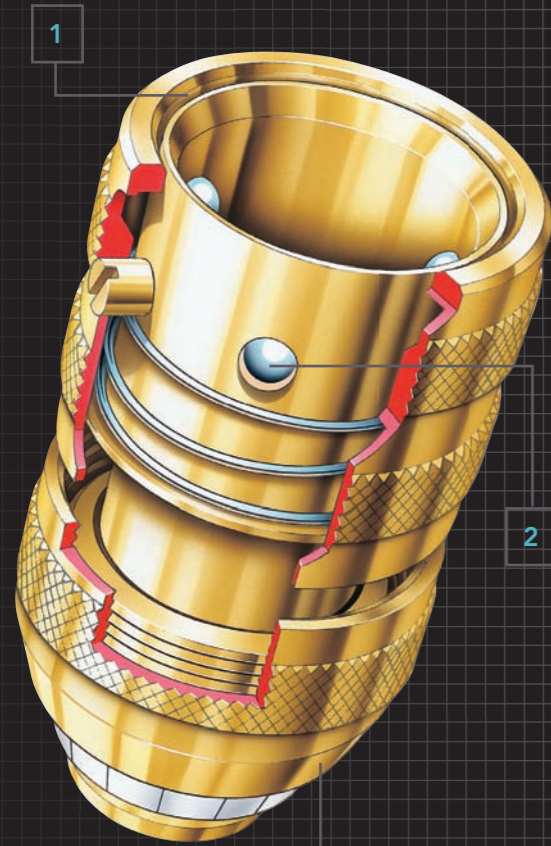

## HOSE PIPES

- Premium quality, triple layered, polyester reinforced for extra strength & resistance to twisting and stretching
- Heavy duty, abrasion resistant PVC outer layer for superior elasticity at low temperatures
- UV stable
- Burst pressure 35 bar



### Pro-Flex hose pipes

Item Number	Length	Ø	Box Qty
G7625 15	15m	13mm 1/2"	10
G7625 30	30m	13mm 1/2"	5
G7625 50	50m	13mm 1/2"	3
G7625 75	75m	13mm 1/2"	2
G7626 15	15m	19mm 3/4"	10
G7626 30	30m	19mm 3/4"	5
G7626 50	50m	19mm 3/4"	3

- High quality, triple layered, polyester reinforced for extra strength & resistance to twisting and stretching
- Abrasion resistant PVC outer layer for long life
- UV stable
- Burst pressure 28 bar



### Multi-Flex hose pipes

Item Number	Length	Ø	Box Qty
G7621 15	15m	13mm 1/2"	10
G7621 30	30m	13mm 1/2"	5
G7621 50	50m	13mm 1/2"	3

## HOSE CONNECTORS



### Hose connector - Male

Item Number	Ø	Box Qty
G7904	1/2"	6
G7934	3/4"	6



### Hose connector - Female

Item Number	Ø	Box Qty
G7903	1/2"	6
G7933	3/4"	6



### Hose connector - Male & female

Item Number	Ø	Box Qty
G7905	1/2"	6



### Hose connector - Double male

Item Number	Ø	Box Qty
G7907	1/2"	6



### Hose connector - Triple male

Item Number	Ø	Box Qty
G7907Y	1/2"	6

- Automatic water cut off feature allows the interchange of accessories such as sprinklers, nozzles, spray guns, etc



### Hose connector - Water stop

Item Number	Ø	Box Qty
G7913	1/2"	6

- Tap connector for threaded taps

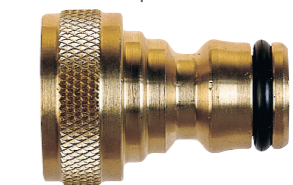

### Tap connector - Threaded female

Item Number	Ø	Box Qty
G7915 50	1/2"	6
G7915 62	3/8"	6
G7915 75	3/4"	6

- Ideal for converting a female threaded tap or other equipment such as jet washers to connect to a female hose coupling

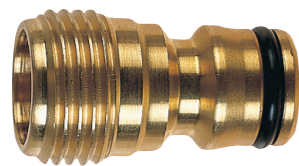

### Tap connector - Threaded male

Item Number	Ø	
G7916 50	1/2"	6
G7916 75	3/4"	6

- For 3/4" external-threaded taps
- Two outlets each featuring a cut off valve that can be individually closed for convenience



### Tap connector - 2 Way

Item Number	Ø	
G7918	3/4"	6

- Tap connector for smooth taps (Not suitable for high water pressures)

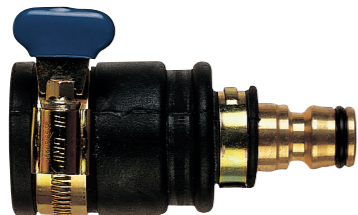

### Tap connector - Push-on

Item Number	i	
G7919	standard bore (10 - 20mm)	3
G7928	large bore (20 - 30mm)	3

- Secure screw down hose connector for permanently joining two hoses or rejoining a hose when a damaged section has been cut out



### Hose repairer

Item Number	Ø	
G7924	1/2"	6
G7932	3/4"	6

## HOSE ACCESSORIES

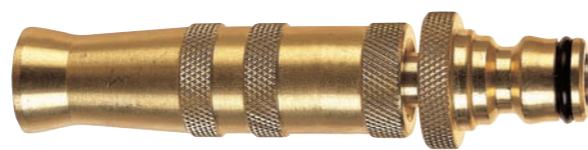

### Adjustable spray nozzle

Item Number	
G7912	6

- Ergonomic design for comfort
- Lockable on/off trigger for convenience



### Adjustable spray gun

Item Number	
G7943	3

CONTENTS: 12 x hose connectors: female (1/2"). 6 x hose connectors: male (1/2"), male & female, double male, triple male & water stop (1/2"). 6 x tap connectors: threaded female (1/2"), threaded female (5/8") & threaded female (3/4"). 3 x tap connectors: threaded male (1/2"), threaded male (3/4"), two-way (3/4"), push-on (standard bore) & push-on (large bore). 6 x hose repairers (1/2"). 6 x adjustable spray guns. 6 x adjustable spray nozzles.



### Hose connector display

Item Number	i	
G7900ALS	stock and stand	1

- Gentle spray pattern for damage free watering of delicate plants
- On/off volume control



### Rose spray

Item Number	900mm 36"	
G7945		3

- Covers 200m<sup>2</sup> at a 5 bar pressure
- Adjustable to 4 modes of spread: full, right, left or centre

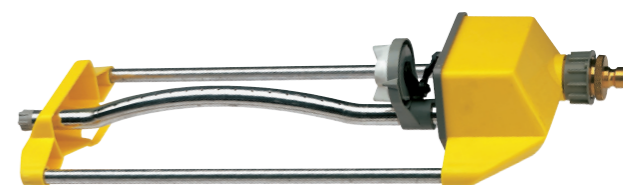

### Lawn sprinkler - Oscillating

Item Number	
G7756BI	1

- Covers 450m<sup>2</sup> at a minimum pressure of 1.2 bar
- Adjustable watering arc for full circle or partial segment coverage

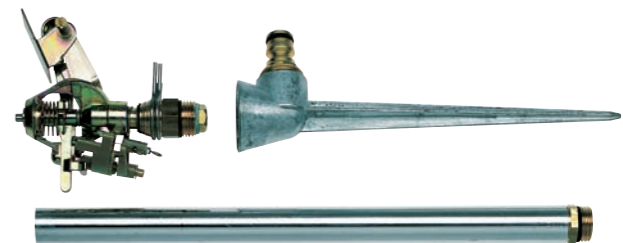

### Lawn sprinkler - Pulse jet

Item Number	
G7755BI	3



### Spare 'O' rings

Item Number	i	
G7980	packet of 20	6

**SENSOPLUS ESD PLIERS & CUTTERS**

SENSOPLUS ESD ZANGEN UND SCHNEIDWERKZEUGE  
PINCES SENSOPLUS ESD  
SENSOPLUS ESD ALICATES Y ALICATES DE CORTE

**145-150****CLASSIC PLIERS & CUTTERS**

KLASSISCHE ZANGEN UND SCHNEIDWERKZEUGE  
PINCES CLASSIQUES  
ALICATES Y ALICATES DE CORTE CLÁSICOS

**151-155****PRECISION WIRE STRIPPERS**

PRÄZISER DRAHTABISOLIERER  
OUTILS À DÉNUDER DE PRÉCISION  
PELACABLES DE PRECISIÓN

**156****CARBOFIB ESD TWEEZERS**

CARBOFIB ESD PINZETTEN  
BRUCELLES CARBOFIB ESD  
CARBOFIBESD PINZAS

**157-158****STAINLESS STEEL TWEEZERS (NO. 4435/AISI 316)**

EDELSTAHPINZETTE (NO. 4435/AISI 316)  
BRUCELLES EN ACIER INOXYDABLE (NO. 4435/AISI 316)  
PINZAS DE ACERO INOXIDABLE (NO. 4435/AISI 316)

**158-160****STAINLESS STEEL TWEEZERS (NO. AISI 420 4034)**

EDELSTAHPINZETTE (NO. AISI 420 4034)  
BRUCELLES EN ACIER INOXYDABLE (NO. AISI 420 4034)  
PINZAS DE ACERO INOXIDABLE (NO. AISI 420 4034)

**160****CARBON STEEL TWEEZERS**

KOHLENSTOFFSTAHL-PINZETTEN  
BRUCELLES EN ACIER AU CARBONE  
PINZAS DE ACERO AL CARBONO

**160-161****CERAMIC TWEEZERS**

KERAMIKPINZETTEN  
BRUCELLES EN CÉRAMIQUE  
PINZAS CERÁMICAS

**161****INSPECTION MIRRORS**

INSPEKTIONSSPIEGEL  
MIROIRS D'INSPECTION  
ESPEJOS DE INSPECCIÓN

**162****PLCC EXTRACTOR**

PLCC-AUSZIEHWERKZEUG  
EXTRACTEUR DE BOÎTIERS PLCC  
EXTRACTOR DE PLCC

**162****ESD BALL PEN**

ESD-KUGELSCHREIBER  
STYLO À BILLE ESD  
BOLÍGRAFO ESD

**162****ESD DESOLDERING TOOL**

ESD-ENTLÖTWERKZEUG  
OUTIL À DESSOUDER ESD  
DESOLDADOR ESD

**162****TRITON ESD SCREWDRIVERS**

TRITON ESD SCHRAUBENDREHER  
TOURNEVIS TRITON ESD  
TRITON ESD DESTORNILLADORES

**163-165****XONIC SCREWDRIVERS**

XONIC SCHRAUBENDREHER  
TOURNEVIS XONIC  
XONIC DESTORNILLADORES

**166-168****PRECISION SCREWDRIVER SETS**

PRÄZISIONS-SCHRAUBENDREHERSÄTZE  
JEUX DE TOURNEVIS DE PRÉCISION  
CONJUNTOS DE DESTORNILLADORES DE PRECISIÓN

**168****XONIC ESD SCREWDRIVERS**

XONIC ESD SCHRAUBENDREHER  
TOURNEVIS XONIC ESD  
XONIC DESTORNILLADORES

**169-171****CERAMIC TRIMMERS**

KERAMIK TRIMMER  
OUTILS DE RÉGLAGE EN CÉRAMIQUE  
HERRAMIENTA DE CERÁMICA PARA REGULACIÓN

**171****PLASTIC TRIMMERS**

KUNSTSTOFFTRIMMER  
OUTILS DE RÉGLAGE EN PLASTIQUE  
HERRAMIENTA DE PLÁSTICO PARA REGULACIÓN

**172**

# ESD & PRECISION TOOLS

ESD- & PRÄZISIONSWERKZEUGE  
OUTILS DE PRÉCISION & ESD  
ESD Y HERRAMIENTAS DE PRECISIÓN







## ESD & PRECISION TOOLS ESD- UND PRÄZISIONSWERKZEUGE OUTILS ESD ET OUTILS DE PRÉCISION HERRAMIENTAS DE PRECISIÓN Y ESD



### WHAT IS ESD?

ESD stands for Electro Static Discharge.

### WAS IST ESD?

ESD steht für Electro Static Discharge (elektrostatische Entladung).

### QUE SIGNIFIE ESD?

ESD est l'abréviation d'Electro Static Discharge, décharge électrostatique en anglais.

### ¿QUÉ SIGNIFICA ESD?

ESD es la abreviación de Electro Static Discharge, es decir descarga electrostatica.

The C.K ESD & Precision range is designed specifically for electronics professionals and technicians that require products of the highest quality for ultra fine work.

Die C.K-Produktbereiche ESD und Präzisionswerkzeuge sind spezifisch für Elektroniker und Ingenieure bestimmt, die Produkte höchster Qualität für ultrafeine Arbeiten benötigen.

La gamme d'outillage ESD et d'outillage de précision de C.K est spécifiquement conçue pour les professionnels de l'électronique et les techniciens qui ont besoin de produits de la plus haute qualité pour des travaux ultra-précis.

La gama de herramientas C.K Precisión y ESD está diseñada específicamente para profesionales y técnicos de la electrónica que requieren productos de la mayor calidad para trabajos de gran precisión.

Electrostatic energy can build up rapidly on a person or object. If two electrically charged objects are brought into contact with each other, a spark may jump from one object to the other in a fast electrostatic discharge. This rapid discharge of electrostatic energy can cause damage to electronic components, particularly during the assembly and maintenance of electronic equipment. C.K ESD tools ensure that electrostatic energy is released in a controlled manner thereby preventing sparks from developing.

Elektrostatische Energie kann sich an einer Person oder einem Objekt schnell aufbauen. Sobald zwei elektrisch geladene Objekte sich berühren, kann von einem Objekt zum anderen ein Funke überspringen. Diese elektrische Entladung verursacht erhebliche Schäden an Komponenten, besonders während der Montage und Wartung. C.K-Werkzeuge gewährleisten, dass elektrostatische Energie kontrolliert abgeleitet wird und verhindert die Entwicklung von überschlagenden Funken.

L'énergie électrostatique peut s'accumuler rapidement sur une personne ou sur un objet. Si deux objets chargés électriquement sont mis en contact l'un avec l'autre, une étincelle peut jaillir d'un objet vers l'autre, constituant une décharge électrostatique rapide. Cette décharge rapide d'énergie électrostatique peut provoquer des dommages sur les composants électroniques, en particulier pendant le montage et la maintenance des matériels électroniques. Avec les outils ESD de C.K, l'énergie électrostatique est libérée de manière maîtrisée, empêchant ainsi la formation d'étincelles.

Energía electrostática puede acumularse rápidamente en una persona o en un objeto. Si entran en contacto dos objetos con carga eléctrica diferente, puede producirse una descarga electrostática rápida ocasionándose así una chispa entre los dos objetos. Esta descarga rápida de energía electrostática puede dañar componentes electrónicos, especialmente durante el montaje o el mantenimiento de aparatos electrónicos. Las herramientas ESD de C.K. garantizan una eliminación controlada de la energía electrostática, evitando así la formación de chispas.

The C.K ESD range is fully compliant with IEC 61340-5-1 ensuring safe use on sensitive equipment.

Der C.K-ESD-Produktbereich erfüllt die Norm IEC 61340-5-1 für eine sichere Anwendung an empfindlichen Komponenten. La gamme ESD de C.K est entièrement conforme à la norme CEI 61340-5-1, ce qui garantit son utilisation sans danger sur les équipements sensibles. La gama C.K. ESD cumple plenamente la norma IEC 61340-5-1, lo que garantiza un uso seguro en equipos sensibles.

## CUTTING EDGES . DIE SCHNEIDEN . TRANCHANTS . FILO DE CORTE

The geometry of the cutting blade determines both the performance and lifetime of the product. A sharper cutting edge reduces 'cutting shock', the energy transmitted to the wire during the cutting process that can cause damage to sensitive components. There is a trade-off however, the sharper the cutting edges, the quicker the blade will wear. The cutting capacity will also be reduced.

Die Geometrie einer Schneidkante bestimmt die Leistung und die Lebensdauer des Produkts. Eine schärfere Schneidkante reduziert beim Schneidvorgang den 'Schneidschock', der auf den Draht übertragenen Energie, die empfindliche elektronische Bauteile beschädigen kann. Dies erfordert jedoch einen Kompromiss, denn je schärfer die Schneidkanten sind, desto schneller verschleißt die Schneide. Außerdem wird die Schneidleistung reduziert.

La géométrie de la lame détermine à la fois l'efficacité et la durée de vie du produit. Une arête plus tranchante réduit le « choc de coupe », c'est-à-dire l'énergie transmise au fil pendant le processus de coupe, énergie qui peut provoquer des dommages sur les composants sensibles. Il s'agit toutefois d'un compromis : plus les arêtes sont tranchantes, plus la lame s'usera rapidement. La capacité de coupe sera également réduite.

La geometría del filo de corte determina tanto el rendimiento como la vida útil del producto. Un filo de corte más afilado reduce el impacto de corte, la energía que se transmite a la alambre durante el proceso de corte que puede provocar daños en los componentes sensibles. Sin embargo, existe la desventaja, que cuanto más afilados estén los filos de corte, más rápido se desgastarán. También se verá reducida la capacidad de corte.



### MINI BEVEL MIT WATE AVEC CHANFREIN MINIBISEL

Standard cut.  
Highest cutting capacity.  
Robust and long lasting.

Standardschnitt.  
Höchste Schneidleistung.  
Robust und lang anhaltend.

Coupe standard.  
Capacité de coupe la plus élevée.  
Robustesse et longévité.

Corte estándar.  
La mayor capacidad de corte.  
Robusta y duradera.



### FULL FLUSH MIT KLEINER WATE AVEC MICRO-CHANFREIN CORTE A RAS COMPLETO

Almost full flush cutting.  
Reduced cutting shock.

Nahezu bündiger Schnitt.  
Reduzierter Schneidschock.

Coupe presque complètement à ras.  
Choc de coupe réduit.

Corte casi completamente a ras.  
Impacto de corte reducido.



### EXTRA FULL FLUSH OHNE WATE COUPE À RAS CORTE A RAS COMPLETO EXTRA

Perfectly flush cutting.  
Suitable for non-shock cutting.

Perfekter bündiger Schnitt.  
Geeignet für Schneiden ohne  
Schneidschock.

Coupe parfaitement à ras.  
Convient pour les coupes sans chocs.

Corte a ras perfecto.  
Adecuado para cortes libres de impacto.



# SENSOPLUS ESD

## DISSIPATIVE PRECISION PLIERS & CUTTERS

PREMIUM-QUALITÄT - ZANGEN UND SCHNEIDWERKZEUGE  
 PINCES DISSIPATIVES DE PRÉCISION  
 HERRAMIENTAS DE CORTE Y ALICATES DE PRECISIÓN ANTIESTÁTICOS



**1 Special alloy steel, drop forged, hardened & tempered for exceptional strength & durability**

Legierter Spezialstahl, gesenkgeschmiedet, gehärtet und angelassen für außerordentliche Festigkeit und Dauerhaftigkeit  
 Acier allié spécial, matricé, trempé pour une résistance et une durabilité exceptionnelles  
 Acero de aleación especial, forjado, endurecido y templado para una resistencia y durabilidad excepcionales

**2 Precision box joint construction for permanent, adjustment free jaw alignment**

Präzises durchgestecktes Gewerbe für permanente, einstellungsfreie Backenausrichtung  
 Construction à charnière entrecassée de précision pour un alignement permanent des mâchoires, ne nécessitant aucun réglage  
 Construcción de la junta de precisión en caja para un alineamiento de las mordazas permanente y sin necesidad de ajustes

**3 Induction hardened jaws for outstanding long term performance**

Induktionsgehärtete Schneiden für lange Lebensdauer  
 Mâchoires trempées par induction pour une efficacité remarquable sur la durée  
 Mordazas templadas por inducción para un excelente rendimiento duradero

**4 Mirror polished surface eliminates the risk of damage from flaking chrome**

Spiegelpolierte Oberflächen als Sicherheit gegen abblätternde Chrompartikel  
 La surface brillante élimine le risque de dommages dus à l'écaillage du chrome  
 Superficie pulida que elimina el riesgo de daños por cromo descascarillado

**5 Spot welded double leaf springs for consistent, repetitive action**

Unverlierbare punktgeschweißte doppelte Blattfedern garantieren optimale Funktion über die gesamte Lebensdauer  
 Ressorts à double lame soudés par points pour une action répétitive constante  
 Muelles de doble hoja soldadas por puntos para obtener una acción homogénea y repetitiva

**6 Ergonomically designed dual component handles for increased comfort & control**

Ergonomisch gestalteter Zwei-Komponenten Griff, rutschhemmend für erhöhten Komfort und bessere Handhabung  
 Branches bicomposant de conception ergonomique pour un confort accru et une meilleure maîtrise de l'outil  
 Mangos de dos componentes y diseño ergonómico para mayor comodidad y control

**7 Fully ESD compliant for safe use on sensitive electronic components**

Vollständig ESD-konform, ableitfähig in allen Bereichen  
 Entièrement conformes ESD pour une utilisation en toute sécurité sur les composants électroniques sensibles  
 Cumple por completo la normativa eléctrica para ESD, para uso seguro con componentes electrónicos sensibles

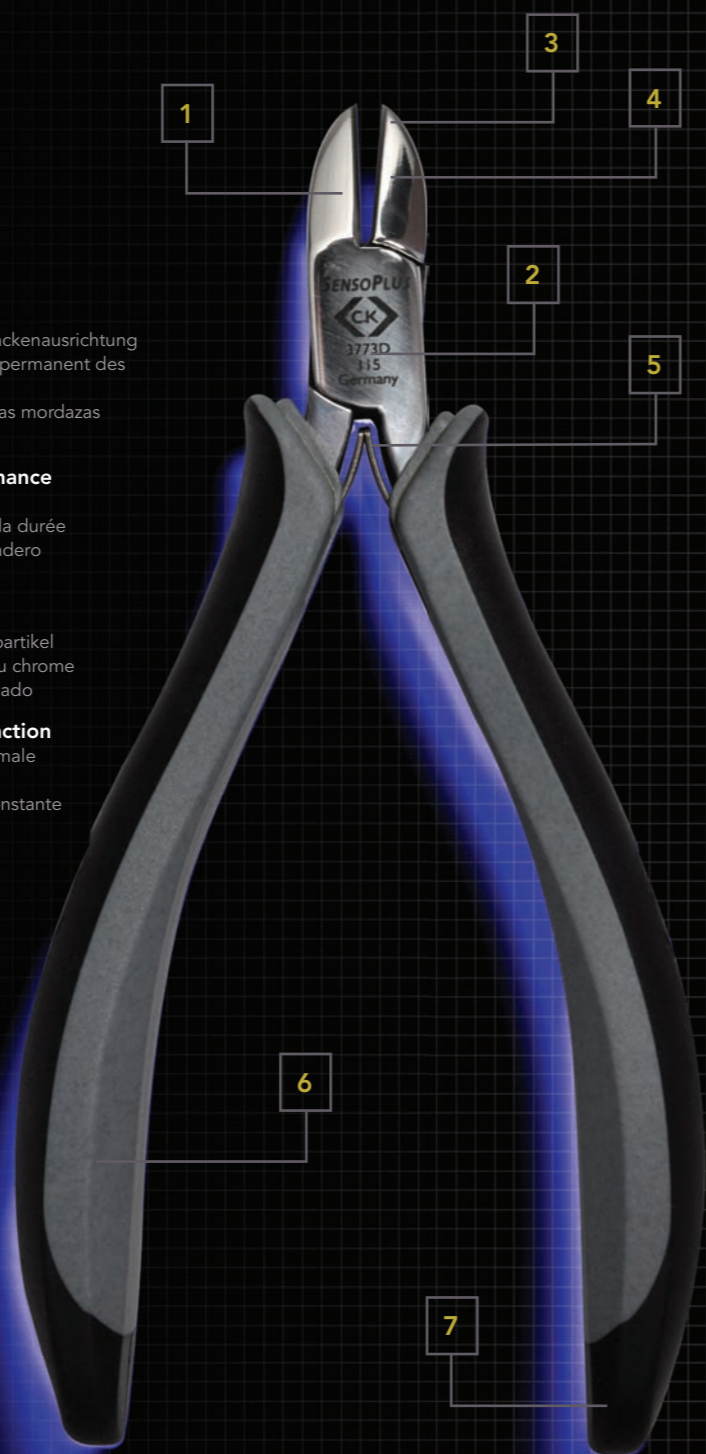

## SENSOPLUS ESD PLIERS & CUTTERS

- Tungsten carbide blades for outstanding cutting life



### Side cutters 3779D

BS EN 61340 2

Item Number	Ø	●	○	WC	📦
T3779D 115	2.0 / 12	1.0 / 18	0.6 / 22	🚫	1

- Tungsten carbide blades for outstanding cutting life



### Side cutters 3787D

BS EN 61340 2

Item Number	Ø	●	○	WC	📦
T3787DF 115	1.8 / 13	0.8 / 20	0.4 / 26	🚫	1

- Tungsten carbide blades for outstanding cutting life



### Oblique cutters 3760D

BS EN 61340 2

Item Number	Ø	●	○	WC	📦
T3760DF 110	2.0 / 12	1.0 / 18	0.6 / 22	🚫	1



### Side cutters 3773D

BS EN 61340 2

Item Number	Ø	●	○	i	📦
T3773D 115	1.5 / 15	1.0 / 18	0.4 / 26	🚫	1
T3773DF 115	1.5 / 15	1.0 / 18	-	🚫	1
T3773DEF 115	1.5 / 15	0.8 / 20	-	🚫	1



### Side cutters 3880D

BS EN 61340 2

Item Number	Ø	●	○	i	📦
T3880DF 110	1.5 / 15	0.8 / 20	0.4 / 26	🚫	1

- Wire catch facility to prevent waste material causing damage to sensitive equipment



### Side cutters 3782D

BS EN 61340 2

Item Number	Ø	●	○	i	📦
T3782D 115	1.5 / 15	1.0 / 18	0.4 / 26	🚫	1
T3782DEF 115	1.5 / 15	0.8 / 20	-	🚫	1



Side cutters 3781D

BS EN 61340 2



Item Number					
T3781D 115	1.5 / 15	1.0 / 18	0.3 / 28		1
T3781DF 115	1.5 / 15	1.0 / 18	-		1
T3781DEF 115	1.5 / 15	0.8 / 20	-		1



Oblique cutters 3799D

BS EN 61340 2



Item Number					
T3799DF 110	1.2 / 16	1.0 / 18	0.4 / 26		1
T3799DEF 110	1.0 / 18	0.8 / 20	-		1

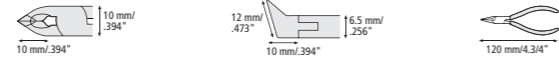

Snipe nose pliers 3772D

BS EN 61340 2



Item Number		
T3772D 120		1
T3772 1D 120		1

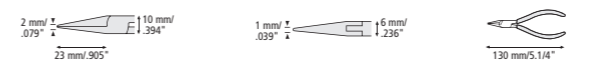

Snipe nose pliers 3769D

BS EN 61340 2



Item Number		
T3769D 150		1

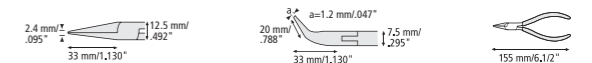

Side cutters 3780D

BS EN 61340 2



Item Number					
T3780DF 110	1.5 / 15	0.8 / 20	-		1



Oblique cutters 3786D

BS EN 61340 2



Item Number					
T3786DF 120	0.8 / 20	0.6 / 22	-		1

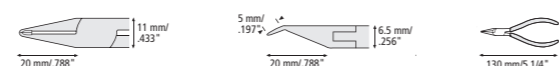

Snipe nose pliers 3777D

BS EN 61340 2



Item Number		
T3777D 150		1

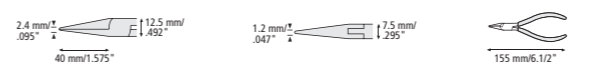

Flat nose pliers 3770D

BS EN 61340 2



Item Number		
T3770 1D 120		1
T3770D 120		1

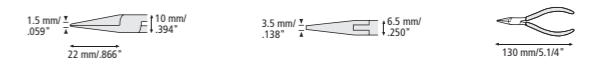

Side cutters 3766D

BS EN 61340 2



Item Number					
T3766DF 110	1.5 / 15	0.8 / 20	-		1
T3766DEF 110	1.5 / 15	0.6 / 22	-		1



Oblique cutters 3871D

BS EN 61340 2



Item Number					
T3871DF 120	0.8 / 20	0.6 / 22	-		1

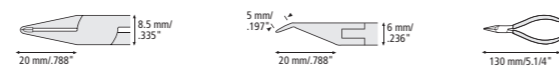

Snipe nose pliers 3767D

BS EN 61340 2



Item Number		
T3767D 120		1

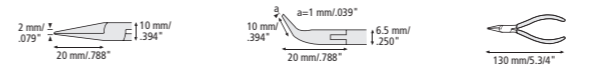

Needle nose pliers 3783D

BS EN 61340 2



Item Number		
T3783D		1

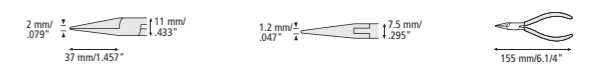



### Round nose pliers 3771D

BS EN 61340 2

Item Number	i	1
T3771D 120		1

CONTENTS: Side cutter T3773D. Snipe nose plier T3772D. Positioning tweezer T2334. Precision tweezer T2343. 1 x screwdriver, slotted, sizes: 1.5 x 60, 1.8 x 60, 2.5 x 60, 2.5 x 75, 3.0 x 100 & 4.0 x 100mm; PH, sizes: 000 x 60, 00 x 60, 0 x 60 & 1 x 80mm.



### ESD tool kit - 14 Piece

BS EN 61340 2

Item Number	1
T3707DX	1

CONTENTS: Side cutter T3773D. Side cutter T3880DF. Side cutter T3766DF. Oblique cutter T3786DF. Snipe nose plier T3772D. Flat nose plier T3770D.



### Pliers set - 6 Piece

BS EN 61340 2

Item Number	1
T3703D	1



## CLASSIC PRECISION PLIERS & CUTTERS

PREMIUM-QUALITÄT - ZANGEN UND SCHNEIDWERKZEUGE  
PINCES DE PRÉCISION  
HERRAMIENTAS DE CORTE Y ALICATES DE PRECISIÓN

#### 1 Special alloy steel, drop forged, hardened & tempered for exceptional strength & durability

Legierter Spezialstahl, gesenkgeschmiedet, gehärtet und angelassen für außerordentliche Festigkeit und Dauerhaftigkeit  
Acier allié spécial, matricé, trempé pour une résistance et une durabilité exceptionnelles  
Acero de aleación especial, forjado, endurecido y templado para una resistencia y durabilidad excepcionales

#### 2 Precision box joint construction for permanent, adjustment free jaw alignment

Präzises durchgestecktes Gewerbe für permanente, einstellungsfreie Backenausrichtung  
Construction à charnière entrepassée de précision pour un alignement permanent des mâchoires, ne nécessitant aucun réglage  
Construcción de la junta de precisión en caja para un alineamiento de las mordazas permanente y sin necesidad de ajustes

#### 3 Induction hardened jaws for outstanding long term performance

Induktionsgehärtete Schneiden für lange Lebensdauer  
Mâchoires trempées par induction pour une efficacité remarquable sur la durée  
Mordazas endurecidas por inducción para un rendimiento duradero y duradero

#### 4 Mirror polished surface eliminates the risk of damage from flaking chrome

Spiegelpolierte Oberflächen als Sicherheit gegen abblätternde Chrompartikel  
La surface brillantée élimine le risque de dommages dus à l'écaillage du chrome  
Superficie esmerilada que elimina el riesgo de daños por descamación del cromo

#### 5 Spot welded double leaf springs for consistent, repetitive action

Unverlierbare, punktgeschweißte, doppelte Blattfedern garantieren optimale Funktion über die gesamte Lebensdauer  
Ressorts à double lame soudés par points pour une action répétitive constante  
Muelles de doble hoja de soldadura por puntos para obtener una acción homogénea y repetitiva

#### 6 PVC handles for comfort & grip

PVC-Griffe für Komfort und Griffigkeit  
Branches PVC pour le confort et la tenue en main  
Mangos de PVC para comodidad y agarre



CLASSIC™

# CLASSIC PLIERS & CUTTERS

- Tungsten carbide blades for outstanding cutting life



Side cutters 3779

Item Number	Ø	Ø	Ø	WC	📦
T3779	2.0 / 12	1.0 / 18	0.6 / 22	🔴	1



Side cutters 3775

Item Number	Ø	Ø	Ø	i	📦
T3775	2.0 / 12	1.5 / 15	0.7 / 21	🔴	1
T3775EF	2.0 / 12	1.3 / 18	-	🟢	1



Side cutters 3773

Item Number	Ø	Ø	Ø	i	📦
T3773	1.5 / 15	1.0 / 18	0.4 / 26	🔴	1
T3773F	1.5 / 15	1.0 / 18	-	🔵	1
T3773EF	1.5 / 15	0.8 / 20	-	🟢	1



Side cutters 3880

Item Number	Ø	Ø	Ø	i	📦
T3880F	1.5 / 15	0.8 / 20	-	🔵	1



Side cutters 3781

Item Number	Ø	Ø	Ø	i	📦
T3781	1.5 / 15	1.0 / 18	0.3 / 28	🔴	1



Side cutters 3780

Item Number	Ø	Ø	Ø	i	📦
T3780F	1.5 / 15	0.8 / 20	-	🔵	1
T3780EF	1.5 / 15	0.6 / 22	-	🟢	1

- Laid-on joint



Side cutters 3774

Item Number	Ø	Ø	Ø	i	📦
T3774	1.5 / 15	1.0 / 18	0.4 / 26	🔴	1



Oblique cutters 3778

Item Number	Ø	Ø	Ø	i	📦
T3778F	1.6 / 14	1.2 / 16	0.5 / 24	🔵	1



Oblique cutters 3799

Item Number	Ø	Ø	Ø	i	📦
T3799F	1.2 / 16	1.0 / 18	0.4 / 26	🔵	1



Top cutters 3776

Item Number	Ø	Ø	Ø	i	📦
T3776F	1.6 / 14	1.2 / 16	0.5 / 24	🔵	1

Item Number	Ø	Ø	Ø	i	📦
T3776EF 5	2.0 / 12	1.6 / 14	-	🟢	1



Oblique cutters 3786

Item Number	Ø	Ø	Ø	i	📦
T3786F 4	0.8 / 20	0.6 / 22	-	🔵	1



Snipe nose pliers 3772

Item Number	i	📦
T3772	🟡	1
T3772 1	🟡	1



Snipe nose pliers 3777

Item Number	i	
T3777		1



Snipe nose pliers 3767

Item Number	i	
T3767		1



Snipe nose pliers 3769

Item Number	i	
T3769		1



Flat nose pliers 3770

Item Number	i	
T3770		1



Flat nose pliers 3789

Item Number	i	
T3789		1



Needle nose pliers 3783

Item Number	i	
T3783		1



Round nose pliers 3771

Item Number	i	
T3771		1

- Laid-on joint



Wire stripping pliers 3796

Item Number	Ø	
T3796 5	0.1 - 0.8mm	1

CONTENTS: Side cutter T3773. Side cutter T3780F. Oblique cutter T3799F. Snipe nose plier T3772. Snipe nose plier T3767. Flat nose plier T3770.



Pliers set - 6 Piece

Item Number	
T3703	1



## PRECISION WIRE STRIPPERS

- Compact precision wire strippers for repeatable, damage free stripping of PVC, Teflon & similar coated wire
- Graduated depth stop for stripping to precise lengths
- Specially hardened blades for outstanding long term performance

- Fully ESD compliant for safe use on sensitive electronic components
- Adjustable to strip 6 wire diameters



### Wire stripper 3757ESD

BS EN 61340 2



Item Number	Ø	
T3757ESD 2	0.25, 0.30, 0.40, 0.50, 0.60, 0.80mm	1

- For fibre optic cable



### Wire stripper 3755

Item Number	Ø	
T3755 018	0.18mm	1



### Wire stripper 3756

Item Number	Ø	
T3756 20	0.20mm	1
T3756 25	0.25mm	1
T3756 30	0.30mm	1
T3756 40	0.40mm	1
T3756 50	0.50mm	1
T3756 60	0.60mm	1
T3756 80	0.80mm	1
T3756 100	1.00mm	1

- Adjustable to strip 6 wire diameters



### Wire stripper 3757

Item Number	Ø	
330009	0.12 - 0.40mm	1
330013	0.25 - 0.80mm	1
330011	0.30 - 1.00mm	1

- Adjustable to strip 6 wire diameters



### Wire stripper 3759

Item Number	Ø	
330012	0.25, 0.30, 0.40, 0.50, 0.60, 0.80mm	1

## CARBOFIB ESD DISSIPATIVE TWEEZERS

ABLEITFÄHIGE PINZETTEN  
BRUCELLES DISSIPATIVES  
PINZAS ANTIESTÁTICAS



### 1 Carbon fibre tips allow for safe handling of highly sensitive electrical components

Carbonfiberspitzen ermöglichen die sichere Handhabung von hochempfindlichen, elektrischen Komponenten  
Pointes en fibre de carbone pour la manipulation en toute sécurité des composants électriques hautement sensibles  
Puntas de fibra de carbono que permiten una manipulación segura de componentes muy sensibles

### 2 High grade, stainless steel bow – acid & corrosion resistant

Hochwertiger Edelstahlbügel - säure- und korrosionsresistent  
Branches en acier inoxydable- résistantes aux acides et à la corrosion  
Arco de acero inoxidable de alta calidad, resistente a la corrosión y al ácido

### 3 Precision welded joint for consistent, repetitive action

Präzise verschweißte Verbindungsstelle für stabile Handhabung und lange Lebensdauer  
Assemblage par soudage de précision pour une action répétitive constante  
Articulación soldada de precisión para que accione de manera coherente y repetitiva

### 4 Fully ESD compliant for safe use on sensitive electronic components

Vollständig ESD-konform, ableitfähig in allen Bereichen  
Entièrement conformes ESD pour une utilisation en toute sécurité sur les composants électroniques sensibles  
Cumple por completo la normativa eléctrica para ESD, para uso seguro con componentes electrónicos sensibles

### 5 Anti-magnetic to prevent electro-magnetic damage

Anti-magnetisch  
Antimagnétiques pour prévenir les dégâts électromagnétiques  
Amagnéticas para evitar los daños electromagnéticos

### 6 Heat resistant up to 270°C for safe use

Hitze resistent bis zu 270°C  
Réfractaires à la chaleur jusqu'à 270°C pour une utilisation en toute sécurité  
Resistente al calor, hasta los 270°C para un uso seguro



## CARBOFIB ESD TWEEZERS

- Fine tips



### Tweezers - Positioning 2390

BS EN 61340 2



Item Number	Length	Type	Material	Quantity
T2390	130mm	CF	259CF	1

- Fine, extra slim tips



### Tweezers - Positioning 2391

BS EN 61340 2



Item Number	Length	Type	Material	Quantity
T2391	130mm	CF	5CF	1

- Rounded tips, 2mm wide



### Tweezers - Positioning 2392

BS EN 61340 2



Item Number	Length	Type	Material	Quantity
T2392	130mm	CF	249CF	1

## STAINLESS STEEL TWEEZERS (NO. 4435/AISI 316)

- High grade, stainless steel bow – acid & corrosion resistant
- Precision welded joint for consistent, repetitive action
- Anti-magnetic to prevent electro-magnetic damage

- Superfine tips, angled at 60°



### Tweezers - Precision 2330

Item Number	Length	Type	Material	Quantity
T2330	110mm	SA	5B.SA	1

- Superfine tips, offset & angled at 60°



### Tweezers - Precision 2331

Item Number	Length	Type	Material	Quantity
T2331	115mm	SA	5C.SA	1

- Superfine tips, straight



### Tweezers - Precision 2341

Item Number	Length	Type	Material	Quantity
T2341	110mm	SA	5B.SA	1

- Fine, sharp tips, straight



### Tweezers - Precision 2340

Item Number	Length	Type	Material	Quantity
T2340	110mm	SA	3C.SA	1

- Fine tips, straight



### Tweezers - Precision 2343

Item Number	Length	Type	Material	Quantity
T2343	130mm	SA	MM.SA	1

- Fine tips, curved



### Tweezers - Precision 2339

Item Number	Length	Type	Material	Quantity
T2339	110mm	SA	7.SA	1

- Flat, blunt tips, finely serrated inside



### Tweezers - Precision 2381

Item Number	Length	Type	Material	Quantity
T2381	120mm	SA	00D.SA	1

- Fine, bent tips, fine cross-cut inside



### Tweezers - Positioning 2359

Item Number	Length	Type	Material	Quantity
T2359	150mm	SA	22.SA	1

- Flat, round tips, straight



### Tweezers - Positioning 2360

Item Number	Length	Type	Material	Quantity
T2360	120mm	SA	2A.SA	1

- Spatula square flat tips



### Tweezers - Flat tip 2364

Item Number	Length	Type	Material	Quantity
T2364	105mm	SA	127.SA	1

- Reverse action
- For SOT-packages, monolithic chip capacitors, etc



### Tweezers - Cross pattern 2349

Item Number	Length	Type	Material	Quantity
T2349	120mm	SA	X104.SA	1

- Cross gripping pattern
- For SOT-packages, monolithic chip capacitors, etc



### Tweezers - Positioning 2334

Item Number	Length	Type	Material	Quantity
T2334	120mm	SA	SM104.SA	1

- Grooved tips angled at 30°
- For cylindrical devices up to 1mm Ø



### Tweezers - Positioning 2336

Item Number	Length	Type	Material	Quantity
T2336	120mm	SA	SM115.SA	1

- Tips round inside
- For cylindrical devices up to 1mm Ø



### Tweezers - Positioning 2351

Item Number	Length	Type	Material	Quantity
T2351	115mm	SA	582.SA	1

- Tips round inside
- For cylindrical devices up to 2mm Ø



### Tweezers - Positioning 2354

Item Number	Length	Type	Material	Quantity
T2354	115mm	SA	578.SA	1

- Fine, straight tips



### Tweezers - Positioning 2316

Item Number	Length	Type	Material	Quantity
T2316	105mm	SA (18/10)		1



- Fine, bent tips



### Tweezers - Positioning 2317

Item Number	Length	Material	Quantity
T2317	105mm	SA (18/10)	1

- Fine, straight extra long tips



### Tweezers - Positioning 2318

Item Number	Length	Material	Quantity
T2318	130mm	SA (18/10)	1

### STAINLESS STEEL TWEEZER (NO. 4034/AISI 420)

- High grade, stainless steel bow – acid & corrosion resistant
- Precision welded joint for consistent, repetitive action

- Fine, straight extra long tips



### Tweezers - Precision 2319

Item Number	Length	Material	Quantity
T2319	120mm	S	1

### CARBON STEEL TWEEZERS

- Hardened, carbon steel bow for long term performance
- Precision welded joint for consistent, repetitive action

- Fine, blunt tips, 2mm wide, finely serrated inside



### Tweezers - Universal 2301

Item Number	Length	Material	Quantity
T2301	115mm	C	1

- Fine, blunt tips, 2mm wide, finely serrated inside
- Matt black anti-glare finish



### Tweezers - Universal 2302

Item Number	Length	Material	Quantity
T2302	115mm	C	1

- Blunt tips, 3.5mm wide, finely serrated inside



### Tweezers - Universal 2307

Item Number	Length	Material	Quantity
T2307	145mm	C	1

- Blunt tips, 3.5mm wide, finely serrated inside
- Matt black anti-glare finish



### Tweezers - Universal 2308

Item Number	Length	Material	Quantity
T2308	145mm	C	1

- Blunt tips, 3.5mm wide, finely serrated inside
- PVC coated



### Tweezers - Universal 2308A

Item Number	Length	Material	Quantity
T2308A	145mm	C	1

- Blunt tips, 2mm wide, fine cross cut inside



### Tweezers - Universal 2309

Item Number	Length	Material	Quantity
T2309	140mm	C	1

- Fine, blunt tips, bent, finely serrated inside
- With guide pin



### Tweezers - Universal 2314

Item Number	Length	Material	Quantity
T2314	150mm	C	1

- Fine, blunt tips, bent, finely serrated inside
- With guide pin
- Matt black anti-glare finish



### Tweezers - Universal 2315

Item Number	Length	Material	Quantity
T2315	150mm	C	1

- Fine, blunt tips, 2mm wide, straight
- Finely serrated inside



### Tweezers - Radio 2327

Item Number	Length	Material	Quantity
T2327	155mm	C	1

- Fine, blunt tips, 2mm wide, bent
- Finely serrated inside



### Tweezers - Radio 2328

Item Number	Length	Material	Quantity
T2328	155mm	C	1

- Reverse action. Soldering tweezers with finger pads to protect against heat
- Fine, bent tips, 2.5mm wide



### Tweezers - Cross pattern 2313A

Item Number	Length	Material	Quantity
T2313A	160mm	C	1

### CERAMIC TWEEZERS

- Zirconia ceramic tips - safe handling of highly sensitive electrical components, highly acid resistant (other than Hydrofluoric), solder repellent & electrically non-conductive
- Heat resistant up to 1000°C for safe use
- Aluminium bow – lightweight construction
- Precision welded joint for consistent, repetitive action
- Non-magnetic to prevent electro-magnetic damage

- Fine, straight tips



### Tweezers - Ceramic 2345A

Item Number	Length	Material	TYPE	Quantity
T2345A	140mm	CER	73 MZ AL	1

## INSPECTION MIRRORS



Inspection mirror - Fixed

Item Number	Length	Ø	Box
T5911 20	164mm	20mm	6



Inspection mirror - Telescopic

Item Number	Length	Ø	Box
T5912 38	125 - 685mm	38mm	6
T5912 55	125 - 560mm	55mm	6



Inspection mirror - Telescopic, long

Item Number	Length	Ø	Box
T5913 32	180 - 520mm	32mm	6



Inspection mirror - Telescopic, extra long

Item Number	Length	Ø	Box
T5914 55	250 - 780mm	55mm	6

## PLCC EXTRACTOR

- For PLCC-components (20-124 pins)
- Self opening for repetitive action
- Fully ESD compliant for safe use on sensitive electronic components



PLCC Extractor

BS EN 61340 2

Item Number	Length	Box
T2371	100mm 4"	6

## ESD BALL PEN



ESD ball pen

BS EN 61340 2

Item Number	Box
Z1123	1

## ESD DESOLDERING TOOL



ESD desoldering tool

BS EN 61340 2

Item Number	Length	i	Box
T6103A	210mm 8 1/4"	desoldering tool	1
T6104A	-	spare nozzle	1

# TRITON ESD

## DISSIPATIVE SCREWDRIVERS

ABLEITFÄHIGE SCHRAUBENDREHER  
TOURNEVIS DISSIPATIFS  
DESTORNILLADORES ANTIESTATICOS



### 1 Ergonomic tri-lobe handle design for comfort & effective delivery of torque

Ergonomischer dreiflügeliger Griff für Komfort und erhöhtem Drehmoment

Manche de conception ergonomique à trois lobes pour le confort et pour une transmission efficace du couple  
Diseño del mango trilobulado y ergonómico para una aplicación cómoda y eficaz del par

### 2 Fully ESD compliant for safe use on sensitive electronic components

Vollständig ESD-konform, ableitfähig in allen Bereichen  
Entièrement conformes ESD pour une utilisation en toute sécurité sur les composants électroniques sensibles  
Cumple por completo la normativa eléctrica para ESD, para uso seguro con componentes electrónicos sensibles

### 3 Toughened alloy steel blade for exceptional strength & durability

Gehärteter Schaft aus legiertem Stahl für außergewöhnliche Festigkeit und Langlebigkeit  
Lame en acier allié durci pour une résistance et une durabilité exceptionnelles  
Hoja de aleación de acero y templado para obtener una resistencia y una durabilidad excepcionales

### 4 Black anti-peel finish eliminates the risk of damage from flaking chrome

Schwarze Klingen, vermeiden Reflexe und Abblättern von Chrompartikeln  
La finition noire anti-écaillage élimine le risque de dommages dus à l'écaillage du chrome  
El acabado elimina el riesgo de descascarillarse el cromo

### 5 Handle injection moulded directly to blade giving the ultimate bond for increased reliability & durability

Direkter Spritzguss des Griffs mit dem Schaft garantiert langlebige Verbindung und Funktion  
Manche moulé par injection directement sur la lame, gage de la meilleure des adhérences pour une fiabilité et une durabilité accrues  
Mango de inyección moldeado directamente en la varilla proporcionando el refuerzo fundamental para una mayor fiabilidad y durabilidad

### 6 Precision machined tip for an exact screw fit & damage free screwdriving

Paßgenaue Spitze für beschädigungsfreies Eindrehen  
Pointe à usinage de précision pour un logement exact dans la tête de vis et un vissage sans dommages  
Punta mecanizada de precisión para el ajuste exacto del tornillo y sin causar daños al atornillar

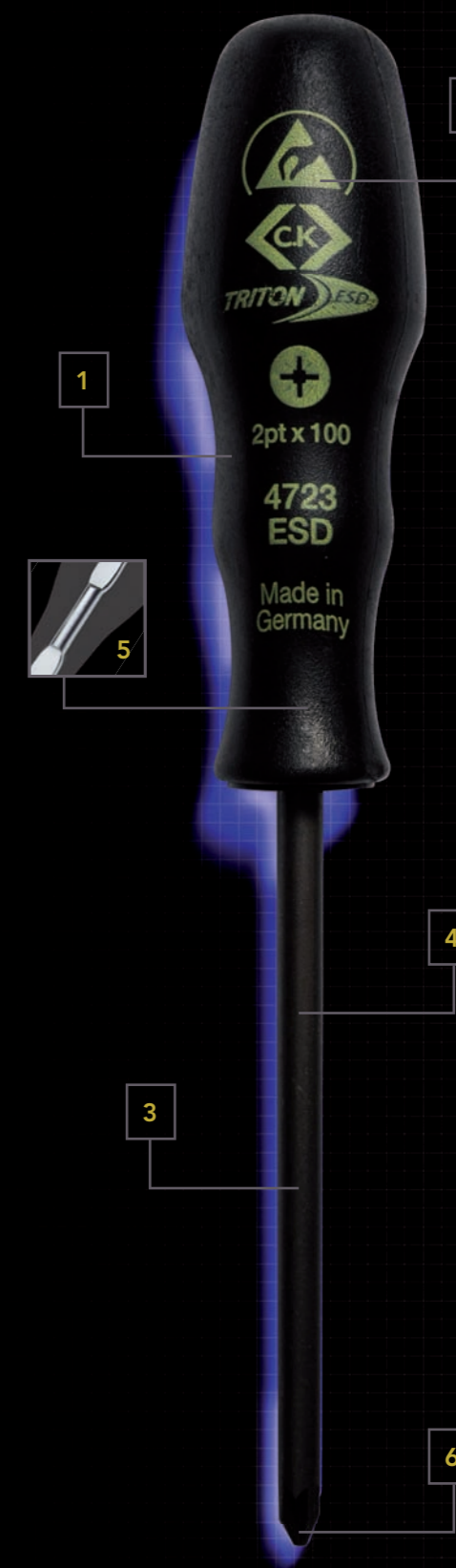

## TRITON ESD SCREWDRIVERS



### Screwdriver - Slotted parallel

BS EN 61340 2, ISO 2380-2, DIN 5264

Item Number	+	Ø	→	←	⊞
T4725ESD 03	3mm 1/8"	75mm 3"	0.5mm 0.02"	70mm 2 3/4"	6
T4725ESD 04	3mm 1/8"	100mm 4"	0.5mm 0.02"	80mm 3 1/8"	6
T4725ESD 41	4mm 5/32"	100mm 4"	0.8mm 0.031"	90mm 3 1/2"	6
T4725ESD 05	5mm 3/16"	125mm 5"	0.8mm 0.031"	90mm 3 1/2"	6
T4725ESD 10	5mm 3/16"	250mm 10"	0.8mm 0.031"	90mm 3 1/2"	6



### Screwdriver - PZ

BS EN 61340 2, ISO 8764

Item Number	+	Ø	→	←	⊞
T4723ESD 0	PZ0	3.5mm 5/16"	60mm 2 1/8"	70mm 2 3/4"	6
T4723ESD 1	PZ1	5.0mm 3/16"	80mm 3 1/8"	90mm 3 1/2"	6
T4723ESD 2	PZ2	6.0mm 7/32"	100mm 4"	100mm 4"	6



### Screwdriver - PH

BS EN 61340 2, ISO 2380-2, DIN 5264

Item Number	+	Ø	→	←	⊞
T4722ESD 0	PH0	3.5mm 5/16"	60mm 2 1/8"	70mm 2 3/4"	6
T4722ESD 1	PH1	5.0mm 3/16"	80mm 3 1/8"	90mm 3 1/2"	6
T4722ESD 13	PH1	5.0mm 3/16"	300mm 12"	90mm 3 1/2"	6
T4722ESD 2	PH2	6.0mm 7/32"	100mm 4"	100mm 4"	6
T4722ESD 23	PH2	6.0mm 7/32"	300mm 12"	100mm 4"	6



### Screwdriver - TX tamperproof

BS EN 61340 2, ISO 2380-2, DIN 5264

Item Number	+	Ø	→	←	⊞
T4718ESD 08	T 08	3.0mm 1/8"	70mm 2 3/4"	80mm 3 1/8"	6
T4718ESD 0820	T 08	3.0mm 1/8"	200mm 8"	80mm 3 1/8"	6
T4718ESD 09	T 09	3.0mm 1/8"	70mm 2 3/4"	80mm 3 1/8"	6
T4718ESD 10	T 10	3.0mm 1/8"	80mm 3 1/8"	90mm 3 1/2"	6
T4718ESD 1030	T 10	3.0mm 1/8"	300mm 12"	90mm 3 1/2"	6
T4718ESD 15	T 15	3.5mm 5/16"	80mm 3 1/8"	90mm 3 1/2"	6
T4718ESD 1530	T 15	3.5mm 5/16"	300mm 12"	90mm 3 1/2"	6
T4718ESD 20	T 20	4.0mm 5/16"	90mm 3 1/2"	90mm 3 1/2"	6



### Screwdriver bit driver

BS EN 61340 2

Item Number	i	Ø	→	←	⊞
T4582ESD	C 6.3 1/4"	11mm 7/16"	125mm 5"	100mm 4"	6

CONTENTS: 1 x slotted, sizes: 3 x 75, 3 x 100 & 5 x 135mm.  
1 x PZ, sizes: 0 x 60, 1 x 80 & 2 x 100mm.



### Screwdriver set - 6 Piece SL/PZ

BS EN 61340 2

Item Number	⊞
T4741ESD	3

CONTENTS: 1 x slotted, sizes: 3 x 75, 3 x 100 & 5 x 135mm.  
1 x PH, sizes: 0 x 60, 1 x 80 & 2 x 100mm.

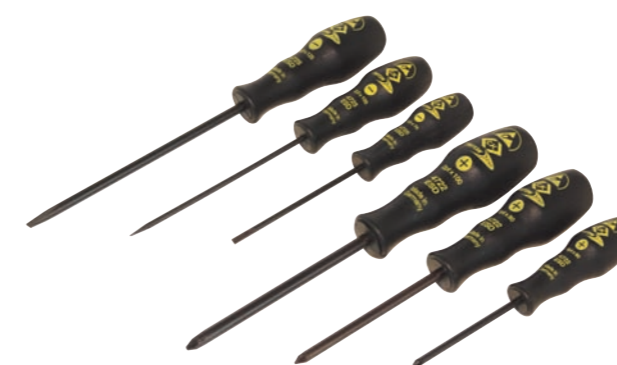

### Screwdriver set - 6 Piece SL/PH

BS EN 61340 2

Item Number	⊞
T4741SESD	3

CONTENTS: 1 x TX, sizes: 8, 9, 10, 15 & 20.



### Screwdriver set - 5 Piece TX

Item Number	⊞
T4730ESD	3

- Long reach screwdrivers

CONTENTS: 1 x slotted, size: 5 x 250mm. 1 x PH, sizes: 1 x 300 & 2 x 300mm. 1 x TX, sizes: 8 x 200, 10 x 300 & 15 x 300mm.



### Screwdriver set - 6 Piece SL/PH/TX

BS EN 61340 2

Item Number	⊞
T4797ESD	3

# XONIC

## PRECISION SCREWDRIVERS

PRÄZISIONSSCHRAUBENDREHER  
TOURNEVIS DE PRÉCISION  
DESTORNILLADORES DE PRECISIÓN



### 1 Ergonomically designed handle with hollow rotating cap for ease of use & precise control

Ergonomisch gestalteter Griff mit drehbarer Muldenkappe für optimale Kontrolle der Drehbewegung auch bei kleinsten Drehmomenten  
Manche de conception ergonomique avec virole creuse pour la facilité d'utilisation et la précision de positionnement  
Mango de diseño ergonómico con extremo giratorio hueco para facilitar el uso y para el control de precisión

### 2 Premium quality chrome vanadium steel blade for exceptional strength & durability

Hochqualitativer Chrom-Vanadiumstahlschaft für außergewöhnliche Festigkeit und Dauerhaftigkeit  
Lame en acier au chrome-vanadium de première qualité pour une résistance et une durabilité exceptionnelles  
Cuchilla de acero al cromo vanadio de alta calidad para una resistencia y durabilidad excepcionales

### 3 Precision machined tip for an exact screw fit & damage free screwdriving

Paßgenaue Spitzen für exakte Anpassungen und beschädigungsfreies Eindrehen  
Pointe à usinage de précision pour un logement exact dans la tête de vis et un vissage sans dommages  
Punta mecanizada de precisión para el ajuste exacto del tornillo y sin causar daños al atornillar

### 4 Black anti-peel tips eliminates the risk of damage from flaking chrome

Schwarze Klingen, nicht verchromt, vermeiden Reflexe und Abblättern von Chrompartikeln  
Les pointes noires anti-écaillage éliminent le risque de dommages dus à l'écaillage du chrome  
El acabado elimina el riesgo de descascarillarse el cromo

### 5 Tip type colour coding for easy identification

Farbcodierte Muldenkappen zur einfachen Erkennung  
Codage couleur du type de pointe pour une identification aisée  
Código de colores para el tipo de punta para una fácil identificación



XONIC™

## XONIC SCREWDRIVERS



### Screwdriver - Slotted parallel

Item Number	Tip	Blade Length	Blade Width	Blade Thickness	Handle Length	Weight
T4880X 08	0.8mm 1/32"	60mm 2 3/8"	0.20mm 0.008"	97mm 3 3/16"	30	
T4880X 12	1.2mm 3/64"	60mm 2 3/8"	0.20mm 0.008"	97mm 3 3/16"	30	
T4880X 15	1.5mm 1/16"	60mm 2 3/8"	0.25mm 0.010"	97mm 3 3/16"	30	
T4880X 18	1.8mm 3/64"	60mm 2 3/8"	0.30mm 0.012"	97mm 3 3/16"	30	
T4880X 256	2.5mm 3/32"	60mm 2 3/8"	0.40mm 0.016"	97mm 3 3/16"	30	
T4880X 257	2.5mm 3/32"	75mm 3"	0.40mm 0.016"	97mm 3 3/16"	30	
T4880X 310	3.0mm 1/8"	100mm 4"	0.50mm 0.020"	97mm 3 3/16"	20	
T4880X 315	3.0mm 1/8"	150mm 6"	0.50mm 0.020"	97mm 3 3/16"	10	
T4880X 410	4.0mm 5/32"	100mm 4"	0.80mm 0.031"	97mm 3 3/16"	30	
T4880X 415	4.0mm 5/32"	150mm 6"	0.80mm 0.031"	97mm 3 3/16"	10	



### Screwdriver - PH

Item Number	Tip	Blade Length	Blade Width	Blade Thickness	Handle Length	Weight
T4882X 000	PH000	2.5mm 3/32"	60mm 2 3/8"	97mm 3 3/16"	30	
T4882X 00	PH00	2.5mm 3/32"	60mm 2 3/8"	97mm 3 3/16"	10	
T4882X 0	PH0	3.0mm 1/8"	60mm 2 3/8"	97mm 3 3/16"	10	
T4882X 1	PH1	4.5mm 11/64"	80mm 3 1/8"	97mm 3 3/16"	30	



### Screwdriver - TX

Item Number	Tip	Blade Length	Blade Width	Blade Thickness	Handle Length	Weight
T4877X 04	T 04	2.5mm 3/32"	50mm 2"	97mm 3 3/16"	30	
T4877X 05	T 05	2.5mm 3/32"	50mm 2"	97mm 3 3/16"	30	
T4877X 06	T 06	3.5mm 9/64"	50mm 2"	97mm 3 3/16"	30	
T4877X 07	T 07	3.5mm 9/64"	50mm 2"	97mm 3 3/16"	30	
T4877X 08	T 08	3.5mm 9/64"	60mm 2 3/8"	97mm 3 3/16"	30	
T4877X 09	T 09	4.0mm 5/32"	60mm 2 3/8"	97mm 3 3/16"	30	
T4877X 10	T 10	4.0mm 5/32"	80mm 3 1/8"	97mm 3 3/16"	30	
T4877X 15	T 15	4.0mm 5/32"	80mm 3 1/8"	97mm 3 3/16"	30	

CONTENTS: 1 x slotted, sizes: 2.5 x 75, 3 x 100, 3 x 150, 4 x 100 & 4 x 150mm. 1 x PH, sizes: 0 x 60 & 1 x 80mm.



### Screwdriver set - 7 Piece SL/PH

Item Number	Weight
T4883X	1

CONTENTS: 1 x slotted, sizes: 2.5 x 75, 3.0 x 100 & 4.0 x 100mm. 1 x PH, sizes: 00 x 60 & 0 x 60mm.



### Screwdriver set - 5 Piece SL/PH

Item Number	Weight
T4880X/5	1

CONTENTS: 1 x slotted, sizes: 1.8 x 60, 3.0 x 100 & 4.0 x 150mm. 1 x PH, size: 0 x 60mm.



### Screwdriver set - 4 Piece SL/PH

Item Number	Weight
T4884X	1

CONTENTS: 1 x hexagon, sizes: 0.7 x 50, 0.9 x 50, 1.3 x 50, 1.5 x 50, 2.0 x 50, 2.5 x 60 & 3.0 x 60mm.



**Screwdriver Set -  
7 Piece Hexagon**

Item Number	
T4874X	1

CONTENTS: 1 x TX, sizes: 6, 7, 8, 9, 10, 15 & 20.



**Screwdriver set -  
7 Piece Torx**

Item Number	
T4877PX	1

**PRECISION SCREWDRIVER  
SETS**

CONTENTS: 1 x screwdriver, slotted, sizes: 1.0 x 15, 1.6 x 20, 2.0 x 22 & 2.4 x 25mm.



**Screwdriver set -  
4 Piece slotted**

Item Number	
T4852P	6

- Blades manufactured from special alloy steel for strength & durability
- Precision machined tips for an exact screw fit

CONTENTS: 1 x screwdriver, slotted, sizes: 1.0 x 15, 1.6 x 20, 2.0 x 22 & 2.4 x 25mm. 1 x PH, sizes: 00 x 25 & 0 x 25mm.



**Screwdriver Set -  
6 Piece SL/PH**

Item Number	
T4854P	6

- Ergonomically designed handle with hollow rotating cap for ease of use & precise control
- Interchangeable double ended blades manufactured from premium quality chrome vanadium/molybdenum steel for strength & durability
- Precision machined tips for an exact screw fit

CONTENTS: Screwdriver handle. 1 x double ended blades, sizes: slotted 1.5mm x PH000, slotted 2.0mm x PH00, slotted 3.0 x PH0, slotted 4.0mm x PH1, 1 x TX; sizes 5, 6, 7 & 8.



**Screwdriver set -  
7 Piece SL/PH/TX**

Item Number	
T4896	6

**XONIC ESD  
DISSIPATIVE PRECISION SCREWDRIVERS**  
ABLEITFÄHIGE PRÄZISIONSSCHRAUBENDREHER  
TOURNEVIS DISSIPATIFS DE PRÉCISION  
DESTORNILLADORES DE PRECISIÓN DISIPANTES



**1 Ergonomically designed handle with hollow rotating cap for ease of use & precise control**

Ergonomisch gestalteter Griff mit drehbarer Muldenkappe garantiert optimale Kontrolle der Drehbewegung auch bei kleinsten Drehmomenten

Manche de conception ergonomique avec virole creuse pour la facilité d'utilisation et la précision de positionnement

Mango de diseño ergonómico con extremo giratorio hueco para facilitar el uso y para el control de precisión

**2 Premium quality alloy steel blade for exceptional strength & durability**

Hochqualitativer Schaft aus legiertem Stahl für außergewöhnliche Festigkeit und Dauerhaftigkeit

Lame en acier au chrome-vanadium de première qualité pour une résistance et une durabilité exceptionnelles

Cuchilla de aleación de acero de alta calidad para una resistencia y durabilidad excepcionales

**3 Precision machined tip for an exact screw fit & damage free screwdriving**

Paßgenaue Spitzen für beschädigungsfreies Eindrehen

Pointe à usinage de précision pour un logement exact dans la tête de vis et un vissage sans dommages

Punta mecanizada de precisión para el ajuste exacto del tornillo y sin causar daños al atornillar

**4 Black anti-peel tips eliminates the risk of damage from flaking chrome**

Schwarze Klingen, vermeiden Reflexe und Abblättern von Chrompartikeln

Les pointes noires anti-écaillage éliminent le risque de dommages dus à l'écaillage du chrome

El acabado antidescamado elimina el riesgo de descamación del cromo

**5 Fully ESD compliant for safe use on sensitive electronic components**

Vollständig ESD-konform, ableitfähig in allen Bereichen

Entièrement conformes ESD pour une utilisation en toute sécurité sur les composants électroniques sensibles

Cumple por completo la normativa eléctrica para ESD, para uso seguro con componentes electrónicos sensibles



## XONIC ESD SCREWDRIVERS



### Screwdrivers - Slotted parallel

BS EN 61340 2

Item Number	Tip	Length	Shaft Dia	Tip Dia	Tip Length	Tip Width	Tip Thickness	Tip Angle	Tip Material	Tip Hardness	Tip Length	Tip Width	Tip Thickness	Tip Angle	Tip Material	Tip Hardness
T4880XES08	0.8mm 1/32"	60mm 2 3/8"	0.20mm	0.008"	97mm	3 1/16"	30									
T4880XES12	1.2mm 3/64"	60mm 2 3/8"	0.25mm	0.010"	97mm	3 1/16"	30									
T4880XES15	1.5mm 1/16"	60mm 2 3/8"	0.30mm	0.012"	97mm	3 1/16"	30									
T4880XES18	1.8mm 3/64"	60mm 2 3/8"	0.30mm	0.012"	97mm	3 1/16"	30									
T4880XES256	2.5mm 3/32"	60mm 2 3/8"	0.40mm	0.016"	97mm	3 1/16"	30									
T4880XES257	2.5mm 3/32"	75mm 3"	0.40mm	0.016"	97mm	3 1/16"	30									
T4880XES310	3.0mm 1/8"	100mm 4"	0.50mm	0.020"	97mm	3 1/16"	30									
T4880XES315	3.0mm 1/8"	150mm 6"	0.50mm	0.020"	97mm	3 1/16"	30									
T4880XES410	4.0mm 5/32"	100mm 4"	0.60mm	0.024"	97mm	3 1/16"	30									
T4880XES415	4.0mm 5/32"	150mm 6"	0.60mm	0.024"	97mm	3 1/16"	30									



### Screwdrivers - PZ

BS EN 61340 2

Item Number	Tip	Length	Shaft Dia	Tip Dia	Tip Length	Tip Width	Tip Thickness	Tip Angle	Tip Material	Tip Hardness
T4875X ESD	PZ0	3.0mm 1/8"	60mm 2 3/8"	97mm	3 1/16"	30				
T4875X ESD 1	PZ1	4.5mm 1/4"	80mm 3 1/8"	97mm	3 1/16"	30				



### Screwdrivers - PH

BS EN 61340 2

Item Number	Tip	Length	Shaft Dia	Tip Dia	Tip Length	Tip Width	Tip Thickness	Tip Angle	Tip Material	Tip Hardness
T4882X000ES	PH000	2.5mm 3/32"	60mm 2 3/8"	97mm	3 1/16"	30				
T4882X000ESD	PH00	2.5mm 3/32"	60mm 2 3/8"	97mm	3 1/16"	30				
T4882X0 ESD	PH0	3.0mm 1/8"	60mm 2 3/8"	97mm	3 1/16"	30				
T4882X1 ESD	PH1	4.5mm 1/4"	80mm 3 1/8"	97mm	3 1/16"	30				



### Screwdrivers - TX

BS EN 61340 2

Item Number	Tip	Length	Shaft Dia	Tip Dia	Tip Length	Tip Width	Tip Thickness	Tip Angle	Tip Material	Tip Hardness
T4877XESD04	T 04	2.5mm 3/32"	50mm 2"	97mm	3 1/16"	30				
T4877XESD05	T 05	2.5mm 3/32"	50mm 2"	97mm	3 1/16"	30				
T4877XESD06	T 06	3.5mm 3/16"	50mm 2"	97mm	3 1/16"	30				
T4877XESD07	T 07	3.5mm 3/16"	50mm 2"	97mm	3 1/16"	30				
T4877XESD08	T 08	3.5mm 3/16"	60mm 2 3/8"	97mm	3 1/16"	30				



### Screwdrivers - Hexagon, ball end

BS EN 61340 2

Item Number	Tip	Length	Shaft Dia	Tip Dia	Tip Length	Tip Width	Tip Thickness	Tip Angle	Tip Material	Tip Hardness
T4838XESD15	3.2mm 1/8"	50mm 2"	2.5mm 3/32"	97mm	3 1/16"	30				
T4838XESD20	3.5mm 3/16"	50mm 2"	2.5mm 3/32"	97mm	3 1/16"	30				
T4838XESD25	4.0mm 5/32"	60mm 2 3/8"	3.0mm 1/8"	97mm	3 1/16"	30				
T4838XESD30	4.5mm 1/4"	60mm 2 3/8"	3.5mm 3/16"	97mm	3 1/16"	30				



### Nut driver

BS EN 61340 2

Item Number	Tip	Length	Shaft Dia	Tip Dia	Tip Length	Tip Width	Tip Thickness	Tip Angle	Tip Material	Tip Hardness
T4840XESD32	3.2mm 1/8"	60mm 2 3/8"	4mm 5/32"	97mm	3 1/16"	30				
T4840XESD35	3.5mm 3/16"	60mm 2 3/8"	4mm 5/32"	97mm	3 1/16"	30				
T4840XESD40	4.0mm 5/32"	60mm 2 3/8"	4mm 5/32"	97mm	3 1/16"	30				
T4840XESD45	4.5mm 1/4"	60mm 2 3/8"	4mm 5/32"	97mm	3 1/16"	30				
T4840XESD50	5.0mm 3/16"	60mm 2 3/8"	4mm 5/32"	97mm	3 1/16"	30				
T4840XESD55	5.5mm 7/32"	60mm 2 3/8"	4mm 5/32"	97mm	3 1/16"	30				

CONTENTS: 1 x slotted, sizes: 2.5 x 75, 3.0 x 100, 3.0 x 150, 4.0 x 100 & 4.0 x 150mm. 1 x PH, sizes: 0 x 60 & 1 x 80mm.



### Screwdriver set - 7 Piece SL/PH

Item Number	Quantity
T4883XESD	1

CONTENTS: 1 x slotted, sizes: 1.8 x 60, 3 x 100 & 4 x 150mm. 1 x PH, size: 0 x 60mm.



### Screwdriver set - 4 Piece SL/PH

Item Number	Quantity
T4884XESD	1

## CERAMIC TRIMMERS

- Zirconia ceramic tips - safe trimming of highly sensitive electrical components, highly acid resistant (other than Hydrofluoric), solder repellent & electrically non-conductive
- Heat resistant up to 1000°C for safe use
- Non-magnetic to prevent electro-magnetic damage



### Ceramic trimmers - Slotted

Item Number	Tip	Length	Shaft Dia	Tip Dia	Tip Length	Tip Width	Tip Thickness	Tip Angle	Tip Material	Tip Hardness
T4845 09	0.9mm 0.035"	15mm 5/8"	0.4mm 0.016"	85mm	3 3/8"	10				
T4845 13	1.3mm 0.051"	15mm 5/8"	0.4mm 0.016"	85mm	3 3/8"	10				
T4845 18	1.8mm 0.071"	15mm 5/8"	0.4mm 0.016"	85mm	3 3/8"	10				
T4845 26	2.6mm 0.102"	15mm 5/8"	0.4mm 0.016"	85mm	3 3/8"	10				



### Ceramic trimmers - PH

Item Number	Tip	Length	Shaft Dia	Tip Dia	Tip Length	Tip Width	Tip Thickness	Tip Angle	Tip Material	Tip Hardness
T4847	PH0	2.6mm 0.102"	15mm 5/8"	85mm	3 3/8"	10				
T4847 0	PH0 special	2.6mm 0.102"	15mm 5/8"	85mm	3 3/8"	10				

- 2 reversible double blade inserts



### Ceramic trimmers - 4 in 1

Item Number	Tip A	Tip B	Tip C	Tip D	Quantity
T4856	0.9mm 0.035"	PH0 special	1.8mm 0.071"	PH0	10
T4856 A	0.9mm 0.035"	PH0 special	1.8mm 0.071"	2.6mm 0.102"	10

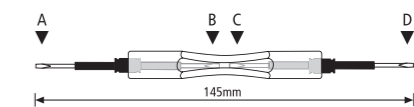

PLASTIC TRIMMERS



Plastic trimmer set - 7 Piece

Item Number									
T4844		1							
i									
	<b>P</b>	0.5mm 0.020"	1.2mm 0.047"	65mm 2 1/2"	85mm 3 3/8"				
	<b>P</b>	0.5mm 0.020"	1.5mm 0.047"	65mm 2 1/2"	85mm 3 3/8"				
	<b>P</b>	0.7mm 0.028"	2.4mm 0.094"	65mm 2 1/2"	85mm 3 3/8"				
	<b>B</b>	0.5mm 0.020"	1.0mm 0.039"	65mm 2 1/2"	85mm 3 3/8"				
	<b>B</b>	0.5mm 0.020"	2.0mm 0.079"	65mm 2 1/2"	85mm 3 3/8"				
	<b>B</b>	0.7mm 0.028"	1.5mm 0.059"	65mm 2 1/2"	85mm 3 3/8"				
	<b>B</b>	0.7mm 0.028"	2.5mm 0.098"	65mm 2 1/2"	85mm 3 3/8"				

P = Plastic B = Brass



Plastic trimmer set - 10 Piece

Item Number							
T4857		3					
		i					
	0.7mm x 1.0mm	□	1.4mm				
	0.5mm x 1.3mm	⬡	1.8mm				
	0.8mm x 2.3mm	⬡	2.5mm				
	0.7mm x 2.0mm	⊙	4mm				
	0.7mm x 2.4mm	⊙	5mm				
	1.3mm	⊙	3mm				
	0.7mm x 1.0mm	⊙	3mm				
	0.8mm x 1.3mm	⊙	3mm				
	0.8mm x 1.8mm	⊙	3mm				
	0.7mm x 2.4mm	⊙	4mm				

# POINT OF SALE

VERKAUFSBEREICH  
MATERIAL PLV  
PUNTO DE VENTA

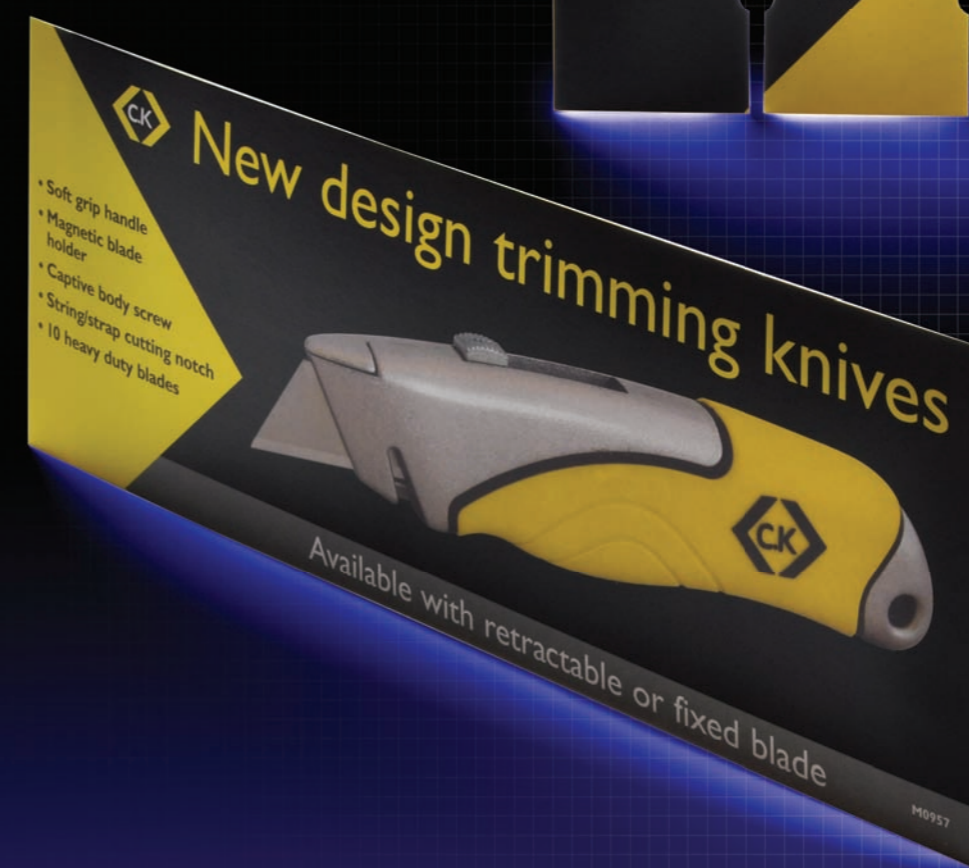



**Highlighter card**  
Redline VDE pliers range

Item Number	450 x 540mm	1
M0017		



**Highlighter card**  
Redline VDE Combicutter range

Item Number	220 x 550mm	1
M39071		



**Highlighter card**  
Redline VDE Combicutter3™

Item Number	160 x 260mm	1
M0014		



**Highlighter card**  
Redline VDE Combicutter3MAX™

Item Number	160 x 280mm	1
M39072		



**Highlighter card**  
RedLine VDE Electrician's pliers

Item Number	160 x 280mm	1
M39077HIE		



**Highlighter card**  
Ratchet crimping pliers range

Item Number	545 x 475mm	1
M3680		



**Highlighter card**  
Universal switch key

Item Number	225 x 210mm	1
M4451		



**Highlighter card**  
Claw hammers - Anti-vibration forged

Item Number	150 x 180mm	Compatible with M0104	1
M0109			



**Highlighter card**  
Club hammer - Anti-vibration

Item Number	150 x 180mm	Compatible with M0104	1
M0111			



**Highlighter card**  
Claw hammers - Anti-vibration fibreglass

Item Number	150 x 180mm	Compatible with M0104	1
M0110			



**Highlighter card**  
Claw hammers - Hi-vis

Item Number	150 x 180mm	Compatible with M0104	1
M0112			



**Header card** Spirit level

Item Number	300 x 210mm	1
M3494		





**Dump bin**  
Sabretooth saw

Item Number		
M8100	500 x 500 x 1250mm	1



**Pallet sleeve**  
Sabretooth saw

Item Number		
M8101	1000 x 1200 x 800mm	1



**Poster** Sabretooth saw

Item Number		
M8102	A3 (297 x 420mm)	1



**Header card** Trimming knife

Item Number		
M0957	310 x 120mm	1



**Header card**  
Trimming knife blade

Item Number		
M0959	310 x 120mm	1



**Single highlighter card**  
Fast4 drill bits

Item Number		
M2943-2	160 x 280mm	1



**Range highlighter card**  
Fast4 drill bits

Item Number		
M2943-1	230 x 600mm	1

# MERCHANDISING

ABSATZFÖRDERUNG  
MERCHANDISING  
COMERCIALIZACIÓN

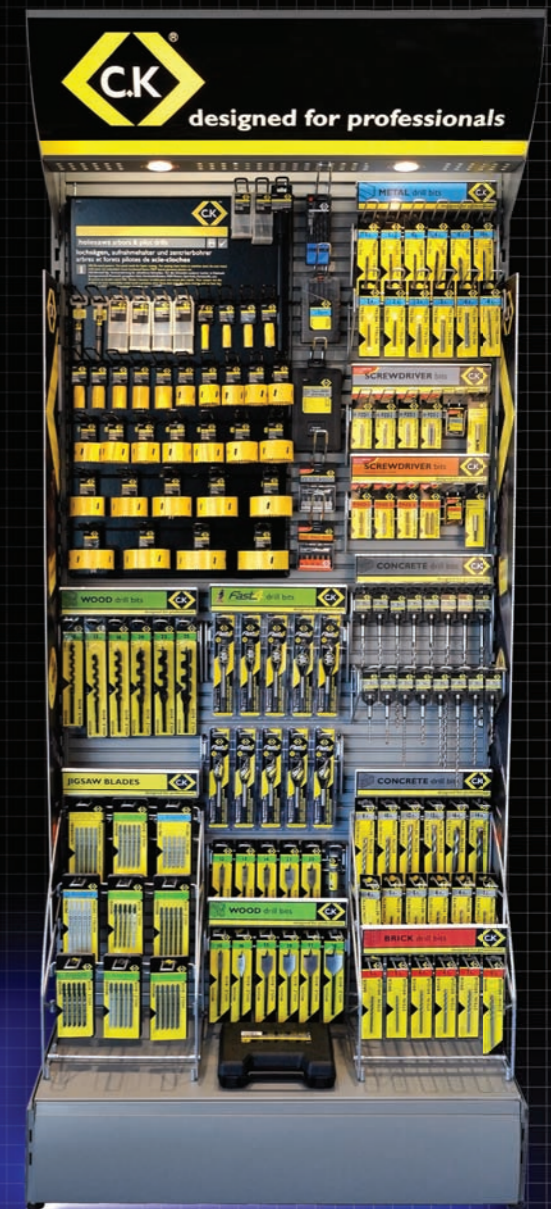
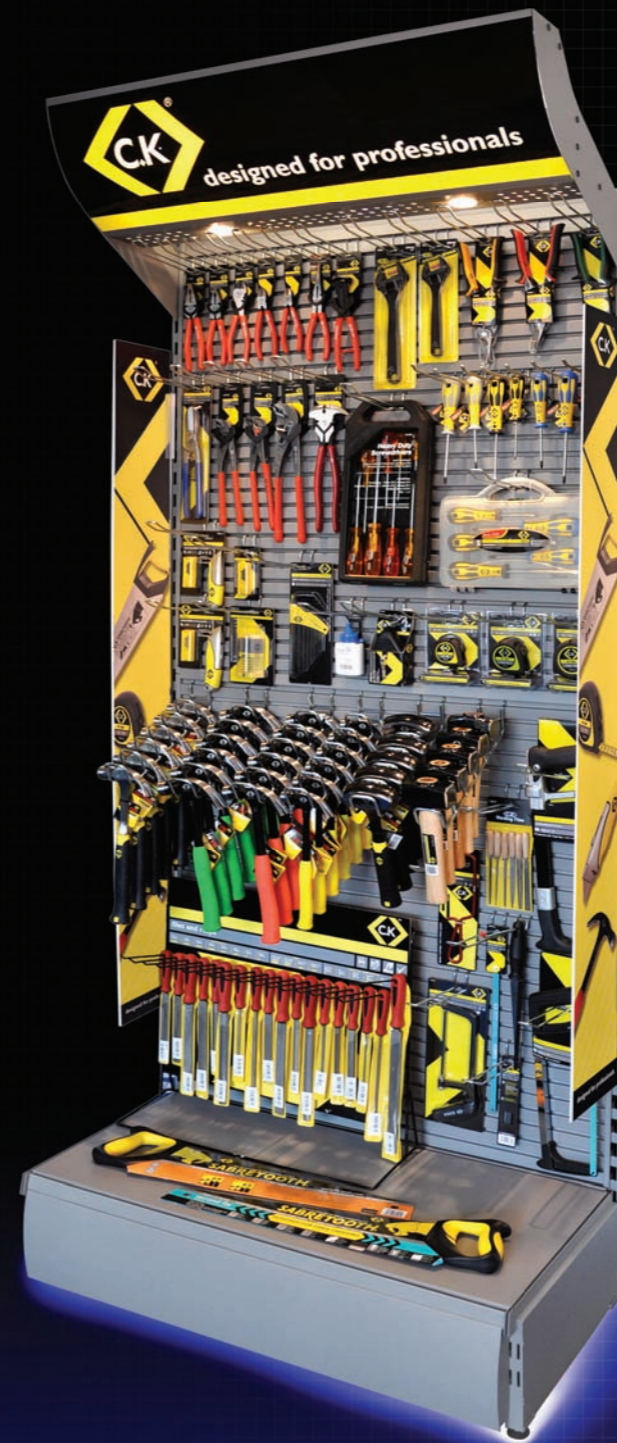

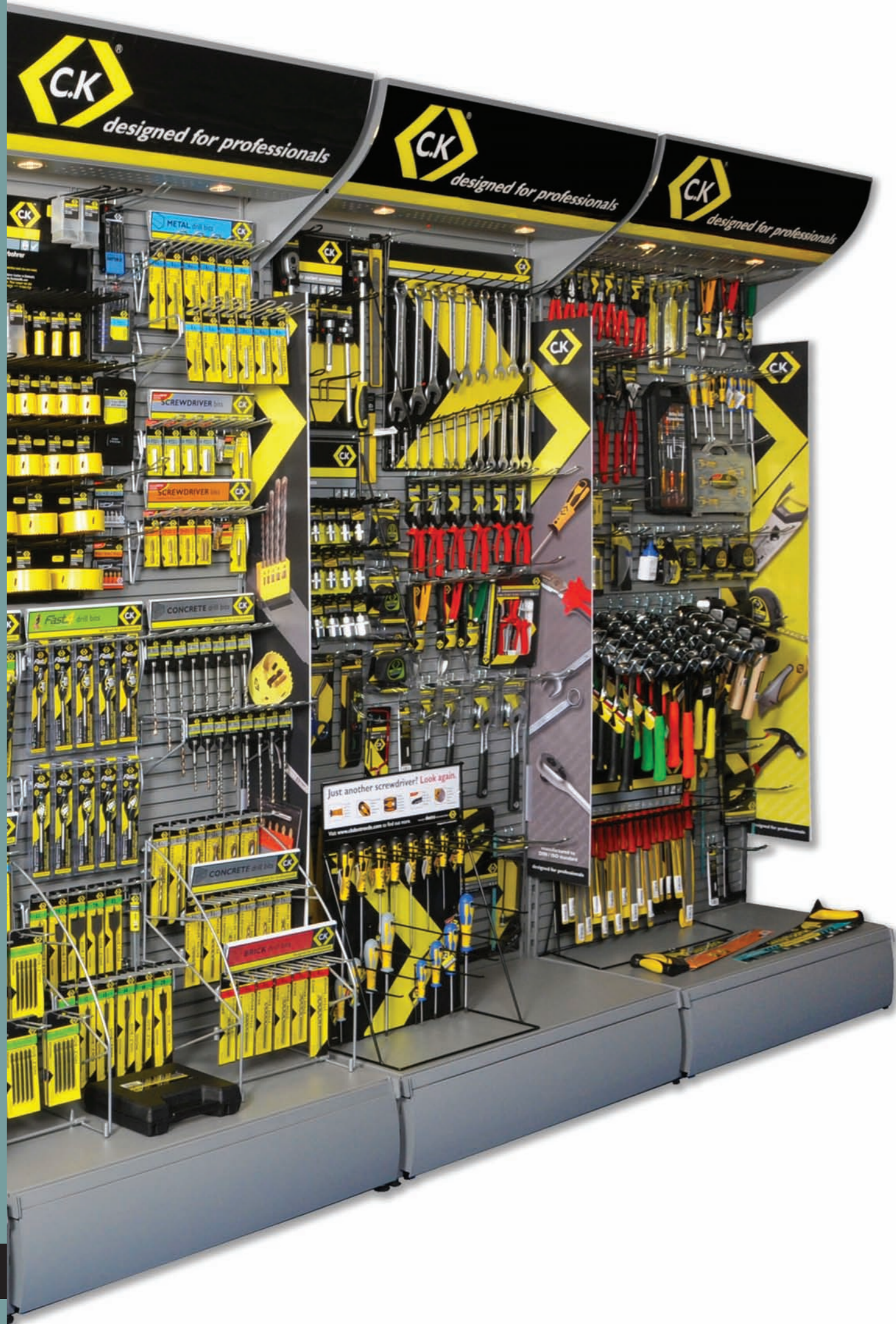

## STRIKING DISPLAYS

Progressive and eye-catching display units have been created to maximise impact in-store, helping to generate incremental sales and encouraging impulse purchases.





## 1 METRE SLAT WALL DISPLAYS

Every market is different, that's why we offer a choice of suggested stock profiles which can be easily adapted to suit your particular business.

- Electrical wholesale
- Engineer's merchants
- DIY / hardware
- Builder's merchants
- Power tool accessories - Electrical wholesale
- Power tool accessories - Builder's merchants

Dimensions - 1m slat wall display:  
W 100cm x H 210cm x D 70cm

## ALPHABETICAL INDEX

PRODUCT	PAGE NUMBER	PRODUCT	PAGE NUMBER
Adhesive trowels	72	Coping saw	89
Adjustable wrenches	101	Countersink bits	123
Auger bits	122	Crimping pliers	21-22
Automatic wire/cable strippers	53-55, 156	Crowbars	63
Jokari	53-54	Cutters	10-11, 15, 18, 25-27, 71, 110-111, 147-148, 152-153
Ball pein hammer	62, 109	Bolt	27
Ball pen	162	Cable & wire rope cutter	27
ESD	162	Cable	11, 15
Basin wrench	70	RedLine	15
Bolsters	64	RedLine VDE	11
Brick	64	Multi cutter	25
Electrician's	64	Oblique	147-148, 153
Bolt cutters	27	Classic	153
Bradawls	47	SensoplusESD	147-148
Brick hammers	62	PVC pipe	25, 71
Brick jointer	68	Side	10-11, 15, 18, 147-148, 152-153
Broad heel trowels	66	Classic	18, 152-153
Cable & wire rope cutter	27	RedLine	15
Cable & wire strippers	10, 13, 16, 53-55, 156	RedLine VDE	10-11
Jokari	53-54	SensoplusESD	147-148
Precision	156	Snips	110-111
RedLine	16	Top	26, 153
RedLine VDE	10, 13	Classic	153
Cable cutters	11, 15	Wire	27
RedLine	15	Damaged screw removers	131
RedLine VDE	11	Desoldering tools	162
Cable knives	52-53	ESD	162
Jokari	52-53	Draw tapes	56
Cable shears	11, 15	Drill bits	114-123
Cable snips	56	Accessories	123
Cable tie gun	56	Brick	116
Carpenter's pencil	84	Straight shank	116
Centre punches	109	Concrete	114-115
Chain saw files	107	SDS-Plus	114-115
Chalk line reels	83	Straight shank	115
Chalk lines	83	Metal	116-119
Chalk powders	83	Multistep	119
Chisels	64-65, 93	Multi-purpose	119
Cold	64	Sets	114-119, 121
Displays	65	Brick	116
Plugging	64	Combination	119
Scutch	65	Concrete	114-115
Sets	93	Metal	117-118
Sharpening stone	93	Multi-purpose	119
Wood	93	Wood	121
Circlip pliers	23	Wood	121-123
Claw hammer	61	Auger	122
Club hammer	61	Brad point	121
Combination pliers	13, 15, 18	Fast4	120-121
Classic	18	Fast4 SDS-Plus	121
RedLine	15	Flat	123
RedLine VDE	13	Drill mixers	69
Combination spanners	100-101	Drill saw	119
Combination squares	85	Dry wall saw	90
		Edging trowel	67
		Electrician's scissors	56
		Engineer's files	106

## SCREWDRIVER MERCHANDISING

Our stylish merchandising system is infinitely flexible and can be used with existing slat wall or peg metal displays, as a counter display unit or as a dedicated single or double sided free standing display.

Dimensions - single side screwdriver display:  
W 50cm x H 160cm x D 40cm

Dimensions - double side screwdriver display:  
W 50cm x H 160cm x D 70cm



# ALPHABETICAL INDEX

PRODUCT	PAGE NUMBER
Engineer's hammers	63, 109
Feeler gauges	85
Files	106-109
Chain saw	107
Displays	107
Engineer's	106
File/rasp	106
Needle	108-109
Saw	107
Sets	108
Warding	108
Wood rasp	107
Filling knives	73
Finger trowels	66-67
Flat bits	123
Flat nose pliers	149, 154
Classic	154
SensoplusESD	149
Floats	69, 72
Grouting	72
Grouting sponge	72
Skimmer	69
Flooring trowels	67
Gauging trowel	68
Glass cutter	72
Glue guns	75
Glue sticks	75
Kit	75
Grouting float	72
Grouting sponge	72
Hacksaw blades	90
Hacksaws	89-90
Hammers	61-63
Ball pein	62
Brick	62
Claw	61
Club	61
Engineer's	63
Joiner's	62
Mortar pick	62
Pin	62
Sledge	62
Handsaws	89, 90
Harling trowel	67
Hexagon keys	102-103
Sets	103
Holesaws	124-126
Arbors	124
SDS-Plus	124
Kits	126
Pilot drill	125
Hose	138
Multi-Flex	138
Pro-Flex	138
Hose & tap connectors	139-141

PRODUCT	PAGE NUMBER
HSS drill bits	116-119
Immersion heater spanner	70
Impact driver & bits	47
Inspection lamps	70
Inspection mirrors	162
Insulated screwdriver sets	32-44
Dextro VDE	32
Triton XLS	44
Jigsaw blades	134-135
Metal	135
Universal	135
Wood	134-135
Joiner's hammers	62
Joiner's squares	84
Junior hacksaws	90
Junior hacksaw blades	90
Knives	92-93
Leaf and square tool	69
Levels	82
Line pins	83
Mainstesters	46
Margin trowel	67
Marking gauges	84
Masonry drills	114-116
SDS-Plus	114-115
Straight shank	115-116
Measuring tapes	81
Fibreglass	81
Steel	81
Surveyor's	81
Mixers & paddles	69
Drill mixers	69
Plasterer's paddle	69
Mortar pick	62
Multicutter	25
Multistep drills	119
Needle files	108
Needle nose pliers	149, 154
Classic	154
SensoplusESD	149
Nut drivers	134
Oblique cutters	147-148, 153
Classic	153
SensoplusESD	147-148
Philadelphia trowel	66, 68
Pincers	26
Pin hammers	62
Pin punches	110
Pipe cutters	25, 70-71
Copper	70
PVC	25, 71
Plasterboard saw	90
Plasterer's hawk	69
Plasterer's paddle	69

PRODUCT	PAGE NUMBER
Plasterer's trowels	68-69
PLCC extractor	162
ESD	162
Pliers	12-27, 149-150, 153-155
Circlip	23
Combination	13-18
Classic	17-18
RedLine	15
RedLine VDE	12-13
Crimping	21-22
Flat nose	149, 154
Classic	154
SensoplusESD	149
Needle nose	149, 154
Classic	154
SensoplusESD	149
Pincers	26
Punch	27
Riveting	24-25
Accessories	24
Displays	25
Round nose	150, 155
Classic	155
SensoplusESD	150
Sets	13, 16, 150, 155
Classic	155
RedLine	16
RedLine VDE	13
SensoplusESD	150
Snipe nose	13, 15, 18, 149, 153-154
Classic	18, 153-154
RedLine	15
RedLine VDE	13
SensoplusESD	149
Tool kits	150
SensoplusESD	150
Waterpump	18-19
Wire stripping	13, 16, 155
Classic	155
RedLine	16
RedLine VDE	13
Plumb bob	83
Pocket balances	85
Pointing trowels	66-68
Prybar	63
Punches	109-110
Centre	109
Parallel	110
Set	110
Punch down tool	57
Punch pliers	27
Putty knife	72
PVC pipe cutter	25, 71
Rasp	106-107
Ratchet screwdriver sets	46-47
Ratchet screwdriver & bits set	46-47
Re-threading tools	57

PRODUCT	PAGE NUMBER
Riveting pliers & rivets	24-25
Accessories	24
Displays	25
Set	24
Round nose pliers	150, 155
Classic	155
SensoplusESD	150
Rules	82
Aluminium	82
Steel	82
Wood	82
Saws	89-90
Blades	89-90
Coping	89
Displays	89-90
Hacksaws	89-90
Junior hacksaw	90
Mini hacksaw	90
Plasterboard (Dry wall)	90
Wood	89
Scrapers	73
Display	73
Filling knife	73
Scraper / filling knives	73
Set	73
Screwdriver bits	127-134
Accessories	134
Bit drivers	134
Sets	129-131
Standard	127-131
TiN coated	132-133
Screwdrivers	28-47, 102-103, 164-171
Dextro	35-37
Displays	37
Dextro VDE	31-33
Displays	33
HD classic	39-41
Displays	41
Hexagon keys	102-103
Impact driver & bits	47
Mainstesters	46
Precision	167-171
Ratchet screwdrivers	46-47
Sets	32, 36, 40, 43-45, 103, 164-165, 167-168, 170-171
Dextro	36
Dextro VDE	32
HD classic	40
Hexagon keys	103
Precision	167-168, 171
Ratchet screwdriver & bits set	46-47
TritonESD	164-165
Triton XLS	44
Xonic	167-168
Triton XLS	43-45
Displays	45
TritonESD	164-165
XonicESD	170-171

# ALPHABETICAL INDEX

PRODUCT	PAGE NUMBER
Sharpening stone	93
Side cutters	10-11, 15, 18, 147-148, 152-153
Classic	18, 152-153
RedLine	15
RedLine VDE	10-11
SensoplusESD	147-148
Skimmer float	69
Slater's ripper	63
Sledge hammers	62
Sliding bevel	84
Snipe nose pliers	13, 15, 18, 149, 153-154
Classic	18, 153-154
RedLine	15
RedLine VDE	13
SensoplusESD	149
Snips	110-111
Sockets	97-99
Accessories	97-98
Displays	97-98
Ratchet handles	97-98
Sets	99
Torque wrench	97
Soldering irons	57
Spanners	70-71, 100-101
Combination	100-101
Displays	101
Immersion heater	70
Open ended	71
Sets	100-101
Spirit levels	82
Aluminium	82
Pocket	82
Sprayers	140-141
Sprinklers	141
Staple guns	74-75
Cable tacker	74-75
Displays	75
Staples	74-75
Steel rule	82
Stillson wrenches	71
Stud extractor sets	111
Suction lifters	72
Surveyor's tape	81
Switch keys	57
Tape measures	80-81
Gel-grip	80
ST	81
Taps & dies	111
Set	111
Tile scribe	72
Tin snips	110
Tool kits	50-51, 150
SensoplusESD	150
Top cutters	26, 153
Classic	153

PRODUCT	PAGE NUMBER
Torque wrench	97
Trimmers	171-172
Precision	171-172
Sets	172
Trimming knives	92-93
Auto retracting	92
Non retractable	92
Retractable	92
Snap off	93
Spare blades	92-93
Trowels	66-68, 72
Adhesive	72
Brick jointer	68
Broad heel	66
Edging	67
Finger	66-67
Flooring	67
Gauging	66-68
Harling	67
Leaf & square tool	69
Margin	67
Philadelphia	66, 68
Plasterer's	68-69
Plasterer's Hawk	69
Pointing	66-68
Trowel & square tools	69
Tweezers	158-161
CarbofibESD	158
Precision	158-161
VDE Screwdrivers & sets	31-33
Dextro VDE	31-33
Vernier caliper	85
Warding files	108
Waterpump pliers	18-19
Wire brush	111
Wire cutters	27
Wire stripping pliers	13, 16, 155
Wood chisels	93
Wood drill bits	121-123
Auger	122
Brad point	121
Fast4	121
Fast4 SDS-Plus	121
Flat	123
Wood saws	89
Wrecking tools	63
Prybar	63
Slater's ripper	63
Wrecking bars	63
Wrenches	70-71, 101-102
Adjustable	101
Basin	70
Self grip	102
Stillson	71

# NUMERICAL INDEX

ITEM	PAGE	ITEM	PAGE	ITEM	PAGE	ITEM	PAGE	ITEM	PAGE	ITEM	PAGE	ITEM	PAGE
330009	156	424040	125	495006	56	G7934	139	T0865B	134	T2315	161	T3064A	119
330011	156	424041	125	495007	56	G7943	140	T0865C	134	T2316	159	T3066	115
330012	156	424042	125	495008	56	G7945	141	T0865H	135	T2317	160	T3066TSBOM	115
330013	156	424043	126	495009	57	G7980	141	T0865L	134	T2318	160	T3068A	115
331001	50	424044	126	495010	57	HDCLASSIC-S1	41	T0865P	135	T2319	160	T3069	116
331002	50	424045	126	495011	57	HDCLASSIC-S2	41	T0865R	135	T2327	161	T3071M	116
331003	51	424046	126	495012	57	HDCLASSIC-S3	41	T0865T	135	T2328	161	T3071TSBOM	116
331004	51	424047	124	495013	57	HDCLASSIC-S4	41	T0865W	135	T2330	158	T3072A	116
356001	63	424048	124	495014	57	HDCLASSIC-TS	41	T0865X	135	T2331	158	T3086	64
356002	63, 109	424049	125	495015	57	M0014	174	T0865Y	135	T2334	159	T3086S	64
357001	61	430001	25, 71	495021	74	M0017	174	T0865RBOM	135	T2336	159	T3087	64
357002	61	430003	25, 71	495022	74	M0109	175	T0903	89	T2339	158	T3087S	64
357003	61	430004	55	495024	74	M0110	175	T0905	89	T2340	158	T3088	64
357004	61	430005	22	495028	57	M0111	175	T0930RBOM	90	T2341	158	T3090LS	65
357005	61	430006	22	495029	57	M0112	175	T0931R	90	T2343	158	T3098	118
395041	55	430007	55	495033	57	M0162	33, 37, 41, 45	T0932R	90	T2345A	161	T3099	117
400002	125	430008	56	496001	74	M3680	174	T0933R	90	T2349	159	T3140	114
406001	65	430018	21	496002	74	M0957	176	T0934R	90	T2351	159	T3140TSBOM	114
406002	65	430020	22	496003	74	M0959	176	T0956	92	T2354	159	T3140RBOM	115
422001	129	430021	21	496004	74	M3494	175	T0957	92	T2359	159	T3144	114
422003	131	430022	21	496005	74	M2943-1	176	T0958	93	T2360	159	T3180	116
424001	124	430025	21	540014	46	M2943-2	176	T0959	92	T2364	159	T3182	117
424002	124	430026	22	581001	89	M39071	174	T0969	92	T2371	162	T3182TSBOM	118
424003	124	430028	22	581002	89	M39072	174	T0971	93	T2381	159	T3182RBOM	119
424005	124	430029	21	595001	51	M8100	176	T10160	52	T2390	158	T3191	117
424006	124	431001	13	595002	51	M4451	175	T10270	52	T2391	158	T3193T	119
424007	124	431002	13	595003	50	M8100	176	T10271	52	T2392	158	T3291	118
424008	124	431003	13	DEXTRO-S1	37	M39077HIE	174	T10280	52	T2463	134	T3293	118
424010	124	431004	10	DEXTRO-S2	37	M8101	176	T10283	53	T2601S	123	T3307P	109
424011	124	431005	11	DEXTRO-S3	37	M8102	176	T1125	84	T2940	123	T3319	109
424012	124	431006	11	DEXTRO-TS	37	T0071	109	T1126	93	T2942	123	T3326	109
424013	124	431007	11	DEXTROVDE-S1	33	T0072	107	T1178	93	T2942TSBOM	123	T3328	110
424014	124	431008	10	DEXTROVDE-S2	33	T0073	107	T1179LS	93	T2942P	123	T3328S	110
424015	124	431009	10	DEXTROVDE-TS	33	T0074	107	T1180	93	T2943	121	T3383	64
424016	124	431012	13	DEXTROVDE-TS	33	T0075	107	T1531	72	T2944	121	T3389LS	65
424017	124	431013	13	G7621	138	T0079	107	T1630 FKIT	50	T2943RBOM	121	T3442	81
424018	124	431014	13	G7625	138	T0080	106	T1881	69	T2944RBOM	121	T3442M	81
424019	124	431015	13	G7626	138	T0080B	106	T1882	69	T30010	53	T3445	80
424020	124	431017	11	G7755BI	141	T0080S	106	T1885	69	T3008	119	T3451	85
424021	124	431019	11	G7756BI	141	T0082	106	T19000	53	T3009	119	T3482	82
424022	124	431030	11	G7900ALS	141	T0083	106	T20030	54	T3010	119	T3490	83
424024	124	431031	11	G7903	139	T0098LS/1	107	T20050	54	T30120	53	T3492	83
424025	124	440007	46	G7904	139	T0106	106	T20060	54	T30140	53	T3494	82
424026	124	440008	46	G7905	139	T0107	107	T20090	54	T30155	53	T3510	82
424027	124	440009	46	G7907	139	T0119	108	T20450	54	T30160	53	T3517	83
424028	124	440012	46	G7907Y	139	T0120	108	T2231	70	T3031	122	T3519	83
424029	124	440013	46	G7912	140	T0120P	108	T2232	70	T3031TSBOM	122	T3520A	83
424030	124	481001	89	G7913	139	T0124P	108	T2235	70	T3033	122	T3521B	83
424031	124	481002	89	G7915	139	T0814	89	T2240	25, 71	T3034	122	T3521R	83
424032	124	484001	55	G7916	140	T0828	89	T2301	160	T3035	121	T3522	83
424033	124	484005	55	G7918	140	T0829	89	T2302	160	T3035TSBOM	122	T3525	85
424034	124	492001	56	G7919	140	T0831	90	T2307	160	T3040	121	T3525M	85
424035	124	495001	55	G7924	140	T0834	90	T2308	160	T3058	117	T3530	82
424036	124	495002	57	G7928	140	T0835	90	T2308A	161	T3060-CBOX	131	T3531	82
424037	124	495003	56	G7932	140	T0836A	90	T2309	161	T3060-CLIP	131	T3533	84
424038	124	495004	56	G7933	139	T0837	90	T2313A	161	T3062	111	T3537	84
424039	124	495005	56	G7933	139	T0865A	135	T2314	161	T3063	119	T3540	84

# NUMERICAL INDEX

ITEM	PAGE	ITEM	PAGE	ITEM	PAGE	ITEM	PAGE	ITEM	PAGE	ITEM	PAGE	ITEM	PAGE
T3541	84	T3773DF	147	T4108A	26	T4545	129	T4727	44	T49163	36	T5913	162
T3542A	84	T3773EF	152	T4112A	26	T4550	127	T4728	44	T49182	32	T5914	162
T3543	84	T3773F	152	T4203	62	T4551	128	T4729	44	T49183	32	T6103A	162
T3561	81	T3774	153	T4204	62	T4551TIN	132	T4730ESD	165	T49192	32	T6104A	162
T3563	81	T3775	152	T4208H	62, 109	T4552	127	T4741ESD	165	T49193	32	T6202	85
T3565	81	T3775EF	152	T4211	65	T4552TIN	132	T4741SESD	165	T4928	47	T6215	75
T3579	85	T3776EF	153	T4218	62	T4553	128	T4797ESD	165	T4965	39	T6215A	75
T3581	85	T3776F	153	T4219	61	T4554	128	T4810	39	T4975	39	T6216	75
T3582	85	T3777	154	T4219A	61	T4555	129	T4811	40	T4977	39	T6218	75
T3621B	18	T3777D	149	T4227A	63, 109	T4555TIN	133	T4812	39	T4987	39	T6219	75
T3622B	18	T3778F	153	T4229	61	T4556	129	T4813	39	T4999B	40	T6222-LS	75
T3623B	18	T3779	152	T4232	62	T4556TIN	132	T4814	39	T5060	67	T6224-LS	75
T3626B	18	T3779D	147	T4234	62	T4557	128	T4815	40	T5064	73	T6227	74
T3627B	18	T3780DF	148	T4310	63	T4557T	128	T4816	40	T5068	68	T6228	74
T3630	102	T3780EF	152	T4311	70	T4557TIN	132	T4826D	46	T5069	69	T6238	111
T3638	102	T3780F	152	T4314	63	T4561	128	T4829D	47	T5070A	73	TRITONXLS-S1	45
T3641	102	T3781	152	T4334M	40	T4561TIN	132	T4831	47	T5070A/LS	73	TRITONXLS-S2	45
T3651	19	T3781D	148	T4343M	100	T4562	127	T4835	47	T5072	68	TRITONXLS-TS	45
T3655	18	T3781DEF	148	T4343M/10ST	100	T4562TSBOM	129	T4838XESD	170	T5073	67	Z1123	162
T3656	19	T3781DF	148	T4343M/12ST	100	T4562TINTSBOM	133	T4840XESD	170	T5075	73	Z3677 1	55
T3659A	19	T3782D	147	T4343MRBOM	101	T4562TIN	132	T4844	172	T5076	72	Z3677 2	55
T3676	21	T3782DEF	147	T4345/6ST	101	T4564EC	134	T4845	171	T5077	73		
T3703	155	T3783	154	T4347	70	T4564SDS	134	T4847	171	T5081	72		
T3703D	150	T3783D	149	T4358	27	T4565	134	T4852P	168	T5082	72		
T3707DX	150	T3786DF	148	T4365	101	T4566	131	T4854P	168	T5087	72		
T3710	23	T3786F	153	T4366	101	T4566TIN	133	T4856	171	T5089	72		
T3711	23	T3787DF	147	T4368	101	T4569TIN	133	T4857	172	T5091	69		
T3712	23	T3789	154	T4371A	27	T4570	134	T4874X	168	T5093	69		
T3713	23	T3796	155	T4381	71	T4579	129	T4875X ESD	170	T5097	67		
T3716	23	T3799DEF	148	T4382	71	T4579TIN	133	T4877PX	168	T5169	72		
T3720	15	T3799DF	148	T4404A	103	T4580TIN	133	T4877X	167	T5172	69		
T3735	71, 102	T3799F	153	T4405A	103	T4581	134	T4877XESD	170	T5173	72		
T3744	27	T3803	16	T4407	103	T4582ESD	164	T4880X	167	T5174	72		
T3750	15	T3804	16	T4411	102	T4583	131	T4880X/5	167	T5180	63		
T3754	16	T3805	13	T4414	103	T4598	134	T4880XES	170	T5198	68		
T3755	156	T3817	27	T4415	103	T4603	98	T4882X	167	T5241	68		
T3756	156	T3819A	24	T4416	103	T4644RBOM	97	T4882X0 ESD	170	T5242	68		
T3757	156	T3820	24	T4417	103	T4645RBOM	98	T4882X000ES	170	T5243	68		
T3757ESD	156	T3820AS	24	T4443M	103	T4655	99	T4882X00ESD	170	T5264	67		
T3760DF	147	T3822A	24	T4444I	103	T4656	99	T4882X1 ESD	170	T5270	66		
T3766DEF	148	T3824	24	T4451-1	57	T4657	99	T4883X	167	T5271	66		
T3766DF	148	T3825LS	25	T4451-2	57	T4690M	97	T4883XESD	171	T5272	67		
T3767	154	T3867	15	T4463	97	T4691	97	T4884X	167	T5273	67		
T3767D	149	T3871DF	148	T4506	110	T4692	97	T4884X ESD	171	T5274	67		
T3769	154	T3880DF	147	T4519	131	T4693	98	T4896	168	T5292	66		
T3769D	149	T3880F	152	T4520	129	T4694	98	T49110	35	T5293	66		
T3770	154	T3906	15	T4521	130	T4695	98	T49112	35	T5295	66		
T3770 1D	149	T3907	15	T4522	130	T4696	98	T49113	35	T5296	66		
T3770D	149	T39071	10	T4523	130	T4718ESD	164	T49117	35	T5297	66		
T3771	155	T39077	12	T4524	130	T4720	43	T49125	35	T5298	68		
T3771D	150	T3909	15	T4525	130	T4722	43	T49142	31	T5299	69		
T3772	153	T3961A	27	T4527	130	T4722ESD	164	T49143	31	T5901	70		
T3772 1D	149	T3963	55	T4528	130	T4723	43	T49144	31	T5901A	70		
T3772D	149	T3964	15	T4536	110	T4723ESD	164	T49145	31	T5902	70		
T3773	152	T3987A	26	T4537AL	110	T4725	43	T49146	31	T5902A	70		
T3773D	147	T3988	26	T4537AR	111	T4725ESD	164	T49153	36	T5911	162		
T3773DEF	147	T4032	111	T4537AS	110	T4726	44	T49162	36	T5912	162		

# TERMS & CONDITIONS

**DEFINITIONS**  
The Buyer: the person, firm or company who purchases Goods from the Company. The Company: Carl Kammerling International Ltd. Goods: All items or services which the Company is to supply to the Buyer.

**CONDITIONS**  
All orders are accepted by the Company subject to and in accordance with the following Conditions of Sale. All orders accepted by the Company are deemed to be under these Conditions and to the absolute exclusion of all other terms and conditions (including any which the Buyer purports to apply under any purchase order, confirmation of order, specification or other document). Each order or acceptance of a quotation for Goods by the Buyer from the Company shall be deemed to be an offer by the Buyer to buy Goods subject to these Conditions.

The sub-headings of these Conditions are for ease of reference only.

**PRICES**  
Goods are invoiced at prices ruling on date of despatch and orders are accepted only on that basis. Prices are correct at time of printing. The Company reserves the right to change prices without prior notice. Any quotation given by the Company shall not be binding until the Company dispatches an acknowledgement of order to the Buyer. Any quotation is valid for a period of 30 days only from its date, provided that the Company has not previously withdrawn it.

**DESPATCH OF GOODS AND DELIVERY**  
(a) UK: Free on orders of £75 net value of Goods when despatched to Buyers premises in UK mainland or Isle of Wight by the Company's normal method of carriage. Northern Ireland, Channel Islands, all UK offshore islands and any non-standard delivery addresses (i.e. not Buyer's own normal delivery address), delivered free of carriage on orders of £125 net value. When a special method of delivery is requested e.g. post, Parcels a.m. service, airfreight, Datapost etc., then carriage will be charged in full regardless of order value.  
(b) Export: For details of freight & insurance, minimum order value and carriage, ask the Buyer's usual sales contact at the Company.  
(c) Any dates specified by the Company for delivery of Goods are intended to be an estimate only and time for delivery shall not be of the essence.  
(d) The Company may deliver the Goods by separate instalments and each separate instalment shall be invoiced and paid for in accordance with these Conditions.

**PACKING**  
Cases and cartons are free and non-returnable.

**TERMS OF PAYMENT**  
(a) UK: All Goods supplied shall be paid for within 25 days from the end of the calendar month in which they are invoiced by the Company.  
(b) Export: For details please ask the Buyer's usual sales contact at the Company.  
(c) Time for payment shall be of the essence.  
(d) No payment shall be deemed to have been received until the Company has received cleared funds.  
(e) Non-compliance with the Company's terms of payment shall constitute default without reminder. In case of default the Company may charge interest at the rate of one and a half percent per month from the date upon which the payment falls due until payment is made. In the event that the Buyer shall fail to fulfil the terms of payment in respect of any invoice the Company may in its sole discretion demand payment of all outstanding balances whether due or not, cancel all outstanding orders and/or decline to make further deliveries except upon receipt of cash or satisfactory security. The Company reserves the right to claim interest under the Late Payment of Commercial Debts (Interest) Act 1998.  
(f) The Buyer shall not be entitled to withhold or set off payment of Goods delivered by virtue of any debt claim or allegation.  
(g) Where any prices quoted are exclusive of VAT, VAT shall be payable in addition (where applicable) at the prevailing rate.  
(h) The Company reserves the right to operate a minimum invoice charge.  
(i) The Company reserves the right to operate a percentage deposit charge.

**PASSING OF RISK**  
The risk in the Goods shall pass to the Buyer when the Company delivers the Goods in accordance with the terms hereof to the Buyer or other person to whom the Company has been authorised by the Buyer to deliver the Goods whether expressly or by implication and the Company shall not be liable for the safety of the Goods thereafter and accordingly the Buyer should insure the Goods thereafter against such risks as may be commercially prudent.

**RESERVATION OF PROPERTY AND RIGHTS OF DISPOSAL**  
(a) Until payment by the Buyer in full of the price for the Goods and any other monies payable to the Company:  
(i) The Goods shall remain the sole and absolute property of the Company as legal and equitable owner.  
(ii) The Buyer shall hold the Goods solely as a fiduciary for the Company and shall store the Goods separately from his own Goods or those of any other person and in a manner which makes them readily identifiable as the Goods of the Company and shall hold the proceeds of sale of the Goods in trust for the Company and shall keep them at all times identifiable as the Company's monies and shall not mingle them with other monies or pay them into an overdrawn bank account.

(iii) The Buyer shall insure the Goods against all normal commercial risk to their full replacement value with an insurance company of repute.  
(iv) The Buyer's right to possession of the Goods shall terminate immediately if the Buyer has a bankruptcy order made against it, or makes an arrangement or composition with its creditors or otherwise takes the benefit of any statutory provision for the time being in force for the relief of insolvent debtors or (being a company) convenes a meeting of creditors (whether formal or informal), or enters into liquidation (whether voluntary or compulsory) except a solvent voluntary liquidation for the purpose only of reconstruction or amalgamation, or has a receiver and/or manager, administrator or administrative receiver appointed, or a resolution is passed or a petition presented for the winding up of the Buyer or for the granting of an administration order or any proceedings are commenced relating to the insolvency of the Buyer.

(b) The Buyer shall be deemed not to have paid the Company for Goods in the possession of the Company at any time unless the Buyer can prove that payment has been received by the Company.  
(c) At any time prior to the payment in full of the price and other monies payable to the Company in respect of the Goods the Company or its agents may enter the premises of the Buyer and take possession of any Goods of which the Company is the owner and remove and dispose of them as the Company sees fit and the Buyer gives the Company an irrevocable licence to enter upon its premises for such purpose.  
(d) The Company shall be entitled to recover payment for the Goods even though ownership has not passed from the Company.

**CARL KAMMERLING INTERNATIONAL GUARANTEE AND WARRANTY**  
All products are provided with a guarantee against faulty materials and/or workmanship. The terms of the guarantee varies from product to product and the details for any particular product are as provided on the Company's individual product brand websites or provided to the Buyer in writing upon request. Any faulty products will be replaced or repaired free of charge at the discretion of the Company in accordance with the relevant guarantee if found to be faulty, provided they are returned immediately to the Company at the Buyer's cost. The reason for return must be clearly stated.

The Company is not liable for the following: Any direct consequential loss or damage of anything whatsoever (including, without limitation, loss of profits, revenue or contracts, pure economic loss or similar loss) or for any damage to or destruction of any property, injury to or death of any person, except to the extent that such injury or death is caused by the negligence on the part of the Company or its employees; costs, damages, charges or expenses caused directly or indirectly by any delay in the delivery of the Goods (even if caused by the Company's negligence) any Goods which have been repaired or altered in any way, any Goods which have been subject to accident or damage or which have been maintained, stored or used improperly, unsuited, inappropriate and faulty application or treatment, normal wear and tear due to use.

All samples, drawings, descriptive matter, specifications and advertising issued by the Company and any descriptions or illustrations contained in the Company's catalogues or brochures are issued for guidance purposes only to give an approximate idea of the Goods described in them and do not form part of these Conditions.

**CLAIMS**  
THE BUYER IS REQUIRED TO NOTIFY THE COMPANY BY TELEPHONE AND THEN CONFIRM BY LETTER REGARDING:  
(a) NON DELIVERY  
To the Company within 3 days of receipt of invoice which is sent to the Buyer on the day following dispatch of Goods.  
(b) SHORTAGES  
To the Company immediately.  
(c) PILFERAGE AND DAMAGE  
To the Company and its carriers within 24 hours of receipt of Goods. Carriers' sheet to be endorsed with details of open or damaged cartons.  
IT IS EMPHASISED THAT DELAY BY THE BUYER MAY CAUSE THE COMPANY'S CLAIM TO BE REJECTED BY THE CARRIERS. IN THIS EVENT THE COMPANY WOULD NOT ACCEPT ANY RESPONSIBILITY FOR LOSS.  
(d) INVOICE QUERIES  
To the Company within 30 days of receipt of invoice.  
(e) The Company shall not be liable for any non-delivery of Goods (even if caused by the Company's negligence) unless the Buyer has so notified the Company in accordance with the above provisions.  
(f) Any liability of the Company for non-delivery of the Goods shall be limited to replacing the Goods within a reasonable time or issuing a credit note against any invoice raised for such Goods.

**LIMITATION OF LIABILITY**  
(a) Subject to the provisions of paragraph (b) of this Condition it is expressly stipulated that in the event of any claim on any ground being made by the Buyer against the Company in respect of the Goods or any matter arising from or in relation to the contract relating thereto the liability the Company shall be limited (in respect of each claim or series of connected claims) to the invoice value of the Goods and under no circumstances shall the Company be under any further liability to the Buyer whether for loss of profit or for any direct or consequential loss howsoever arising.

(b) Notwithstanding any provisions herein contained nothing in these Conditions shall operate or be construed as operating to exclude or restrict any liability of the Company for death or personal injury resulting from the negligence of the Company.  
(c) Whilst every care is taken in handling Goods by the Company's employees liability is excluded for any damage to such Goods by any cause whatsoever.  
(d) On electrical devices liability is excluded for any unforeseen circumstances brought about by power failure or spiking (not notified to the Company before installation of the equipment).

**RETENTION OF DOCUMENTS**  
The Company will retain all documents relating to orders etc. for a maximum period of 2 years.

**RETURNS**  
Goods supplied correctly to Buyer's order cannot be accepted for return or exchange unless by prior agreement in writing and a minimum 10% handling charge will be made.

**SPECIFICATION**  
Due to the Company's policy of continuous improvement it reserves the right to alter specifications without prior notice. The Company also reserves the right to substitute items which have been discontinued or improved with the replacement model.

**PREVIOUS CONDITIONS**  
If at any time one or more of the above conditions becomes in whole or in part invalid, illegal or unenforceable in any respect under any law the validity, legality and enforceability of the remaining provisions thereof and of the other Conditions herein shall not in any way be affected or impaired thereby.

**STANDARD QUANTITIES**  
The column headed 'box qty' in the catalogues and price lists indicates the number of items contained in outer cartons. The Company reserves the right to amend the Buyer's order quantities to the nearest outer carton quantity.

**FORCE MAJEURE**  
The Company reserves the right to defer the date of delivery or to cancel any order for Goods or to reduce the volume of Goods delivered without liability to the Buyer if it is prevented from or delayed in the carrying on of its business due to circumstances beyond its reasonable control, including (without limitation), acts of God, governmental actions, war or national emergency, acts of terrorism, protests, riot, civil commotion, fire, explosion, flood, epidemic, lock-outs, strikes or other labour disputes (whether or not relating to either party's workforce), or restraints or delays affecting carriers or inability or delay in obtaining supplies of adequate or suitable materials, provided that, if the event in question continues for a continuous period in excess of 3 months, the Buyer shall be entitled to give notice in writing to the Company to cancel the order.

**GOVERNING LAW**  
All contracts shall be governed by English Law. In the event of any dispute whether of interpretation or otherwise or as the liability either of the Company or the Buyer arising out of the sale, use or operation or failure to operate the Goods or of any part thereof the same shall be determined by English Courts of Law to whose jurisdiction the Company and the Buyer hereby submit.

**GENERAL**  
(a) Each right or remedy of the Company under these Conditions is without prejudice to any other right or remedy of the Company, whether under these Conditions or otherwise.  
(b) Failure or delay by the Company in enforcing any provision of these Conditions shall not be construed as a waiver of any of its rights under these Conditions.  
(c) Any waiver by the Company of any breach of, or any default under, any provision of these Conditions by the Buyer shall not be deemed a waiver of any subsequent breach or default and in shall no way affect the other terms of these Conditions.  
(d) It is not intended that the any term of these Conditions shall be enforceable by virtue of the Contracts (Rights of Third Parties) Act 1999 by anyone other than the Buyer and the Company.

**Carl Kammerling International**

United Kingdom  
Carl Kammerling International Ltd  
Glanndon Industrial Estate,  
Pwllheli,  
LL53 5LH  
Tel: +44 (0) 1758 701070  
Fax: +44 (0) 1758 704777  
E-mail: sales@cki.uk.com  
www.carlkammerling.com

## ICON KEY

	Size		Screwdriver blade length		Hexagon key
	Piano wire		Screwdriver handle length		Cupboard key
	Hard wire		Hexagon key long arm length		Flattened round
	Medium wire		Hexagon key short arm length		Tapered square
	Soft wire		Weight		Tape blade width
	Information		Lifting capacity		Tape blade width
	Approved & independently audited by the German VDE Institute		Slotted tip		Rule width
	Conforms to IEC 60900:2004		Pozi (PZ) tip		Half round file
	GS tested & certified for safety		Phillips (PH) tip		Flat file
	ESD (IEC 61340-5-1 compliant)		Modulo tip		Round file
	Diameter		TX tip		Triangular file
	Conforms to DIN standards		TX tamperproof tip		Square file
	Mild steel (standard)		Hexagon tip		Half round rasp
	High tensile steel (standard)		Shank diameter		Flat rasp
	Blade direction		Bolster chisel blade width		Flat file/rasp
	Round jaw		Finger trowel blade width		Cutting thickness
	Flat jaw		Tooth width		Thread pitch
	Parallel jaw		WEEE compliant	<b>WC</b>	Tungsten-carbide cutting edges
	Coax crimp		Saw blade pitch	<b>TYPE</b>	Type
	Ferrule crimp		Teeth per inch		Standard cut
	Ferrule crimp		Spanner size		Full flush cut
	Insulated crimp		Square key - Large		Extra full flush cut
	Non insulated crimp		Square key - Medium		Serrated jaws
	Modular crimp		Square key - Small		Smooth jaws
	Slotted blade length		Triangular key - Large		Box quantity
	Slotted blade width		Triangular key - Medium	<b>mm<sup>2</sup> / AWG</b>	Wire size
			Triangular key - Small	<b>BOSCH</b>	Equivalent Bosch item reference

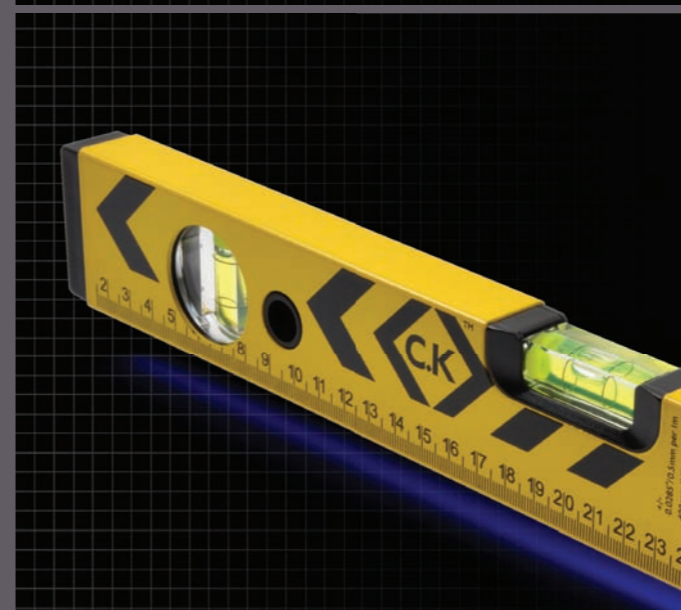
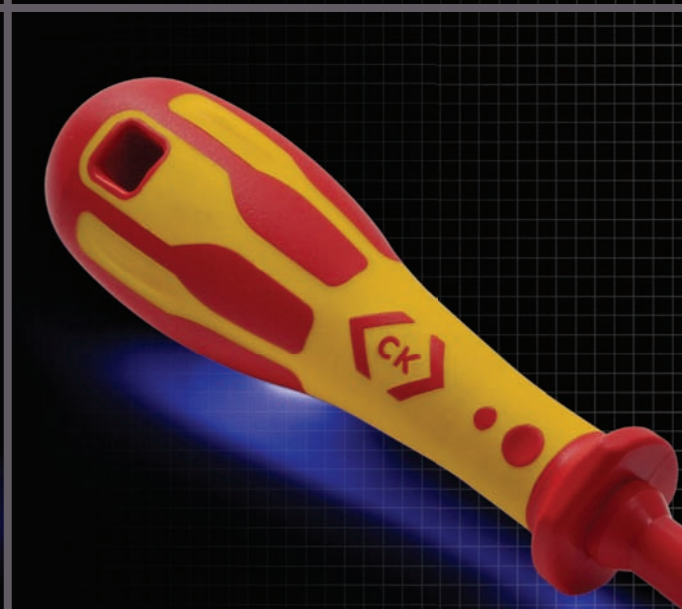
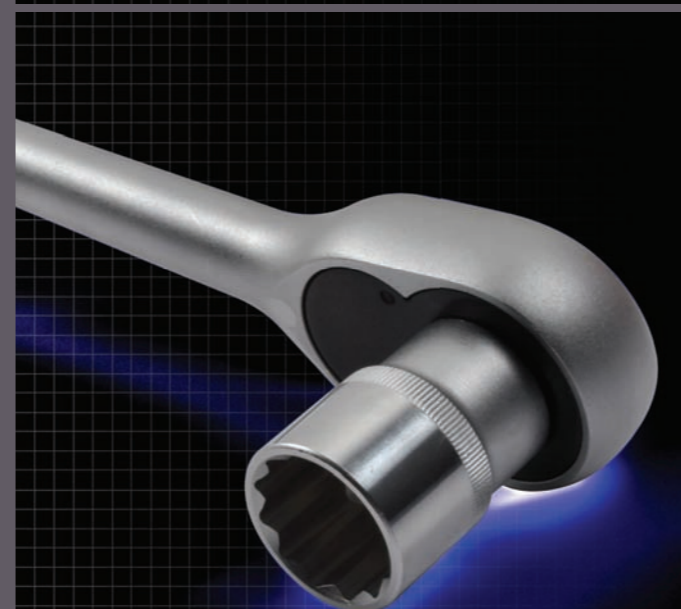
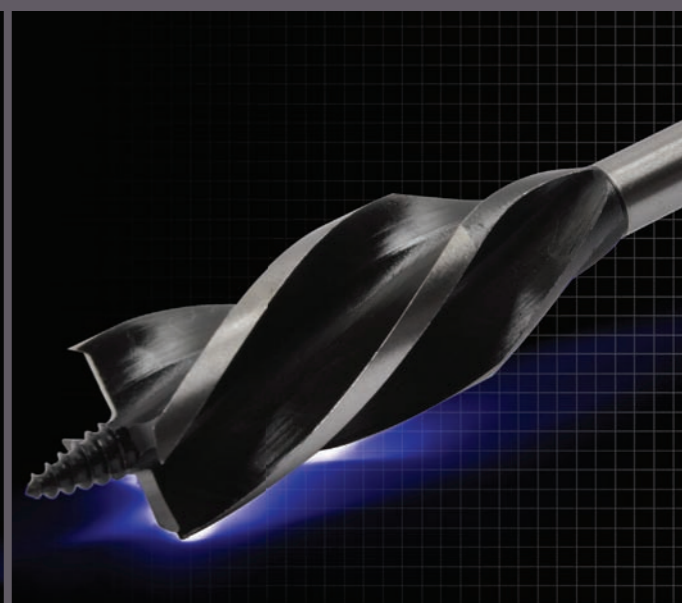
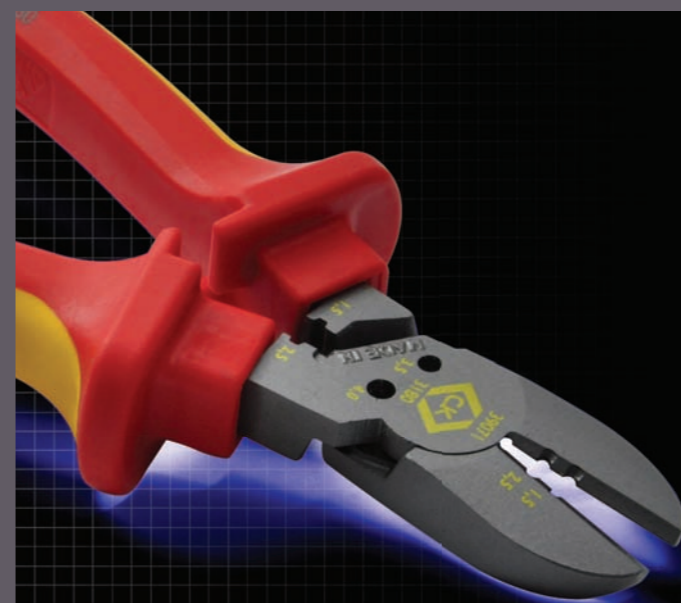

Carl  
Kammerling  
International

Brand  
Innovation

Head Office:

United Kingdom  
Carl Kammerling International Ltd.  
Pwllheli, LL53 5LH  
Tel: +44 (0)1758 701070  
Fax: +44 (0)1758 704777  
email: sales@cki.uk.com

[www.carlkammerling.com](http://www.carlkammerling.com)

Carl Kammerling International's  
Distribution Partners:

Republic of Ireland  
Tel: 1-800818 660  
Fax: 1-800818 659  
email: dublin-sales@cki.uk.com

Germany and Rest Of World  
Carl Kämmerling GmbH & Co. KG  
Bendahler Str. 110,  
42285 Wuppertal

Tel: +49 (0) 202.89030  
Fax: +49 (0) 202.890322  
email: info@cki.de.com

USA  
C.K North America Inc.  
52 Eisenhower Lane North  
Lombard IL 60148  
Tel: +1 (866) 484.5943  
Fax: +1 (630) 953.2686  
email: ckusanick@aol.com

France  
Tel: +33 (0) 810 000044  
Fax: +33 (0) 810 000357  
email: info@cki.de.com

Carl Kammerling International Ltd. reserves the right to alter products and / or specifications without prior notice. Prices are correct at time of printing E. & O.E. All trademarks are acknowledged. All photographs are for guidance only and do not necessarily represent the products illustrated.

©2011. Published by Carl Kammerling International Ltd. No part of this publication may be produced without prior permission from Carl Kammerling International Ltd.

M4011ENG 10k / 01-11